

TSUBAKI SHOCK RELAY SB Series

Electrical Overload Protectors

SHOCK RELAY
SB series



Improved ease of use

Even better usability thanks to the combination of a self-holding type and an automatic reset type. Also, the built-in CPU allows for stable current detection.

Electrical Overload Protector
SHOCK RELAY

Introduction of the new SB Series!

▶ Integrated CT type ◀



▶ Externally mounted CT type ◀



- ▶ Select between a self-holding output relay or an automatic reset output relay
- ▶ Compact thanks to an integrated CT
- ▶ Compatible with a wide range of power sources
Standard products are compatible with AC/DC24 to 240V power sources.
- ▶ Stable current detection
Using the digital circuitry of the built-in CPU allows for even more stable current detection.
- ▶ CE marking
- ▶ RoHS compliant
- ▶ CCC certification, UL/cUL certification



Jamming detection in packaging machines

(To prevent damage to cutters)

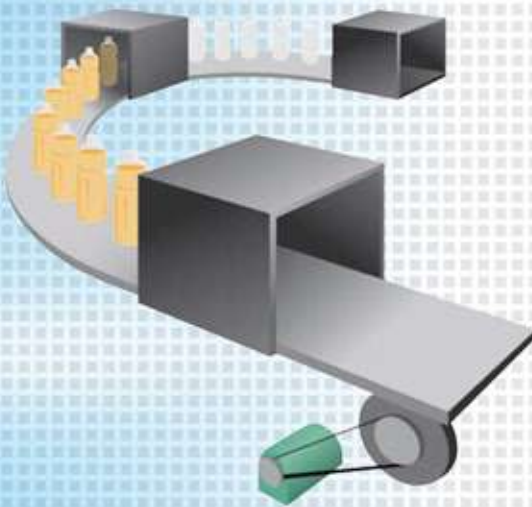

Overload protection for washers

(Usable in machines that use water because it is installed in the control panel)

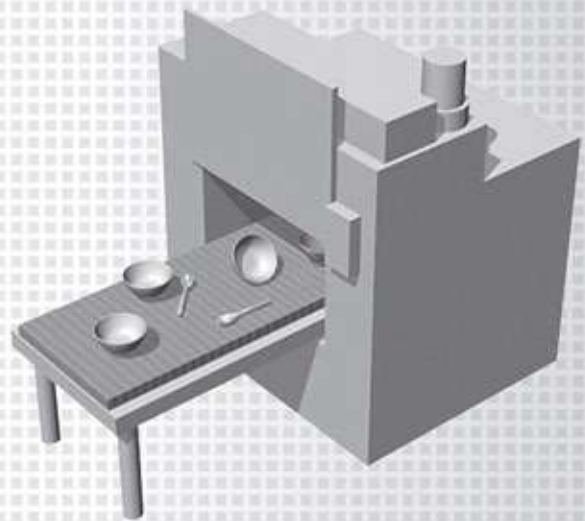

Shredders

(To enable a temporary stop when the load becomes excessive)

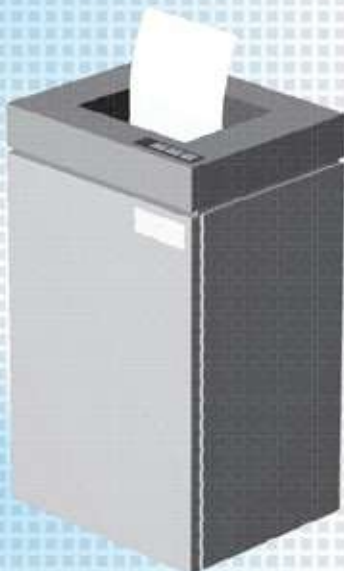

Various other applications

- ▶ Lifting equipment
- ▶ Chip conveyors
- ▶ Screw conveyors
- ▶ Mixers
- ▶ Water treatment facilities
- ▶ Garbage disposal facilities
- ▶ Feeders
- ▶ Food processing machines, etc.

What is the SHOCK RELAY?

▶ Quick overcurrent detection ◀

The SHOCK RELAY outputs a signal if the current from a motor exceeds the set value for longer than the set amount of time. For example, when foreign material causes a conveyor to jam, the signal from the SHOCK RELAY can help minimize damage to the equipment.

▶ Easy to install on existing equipment ◀

Because the SHOCK RELAY is an electric protection device, it can be mounted on existing equipment without making intensive mechanical modifications similar to mechanical protection devices.

▶ Operates only when an overcurrent occurs ◀

The shock time setting makes it possible to prevent a motor from shutting down due to device-specific pulsations or short over-current occurrences.

Operation modes

▶ Overload operation mode ◀

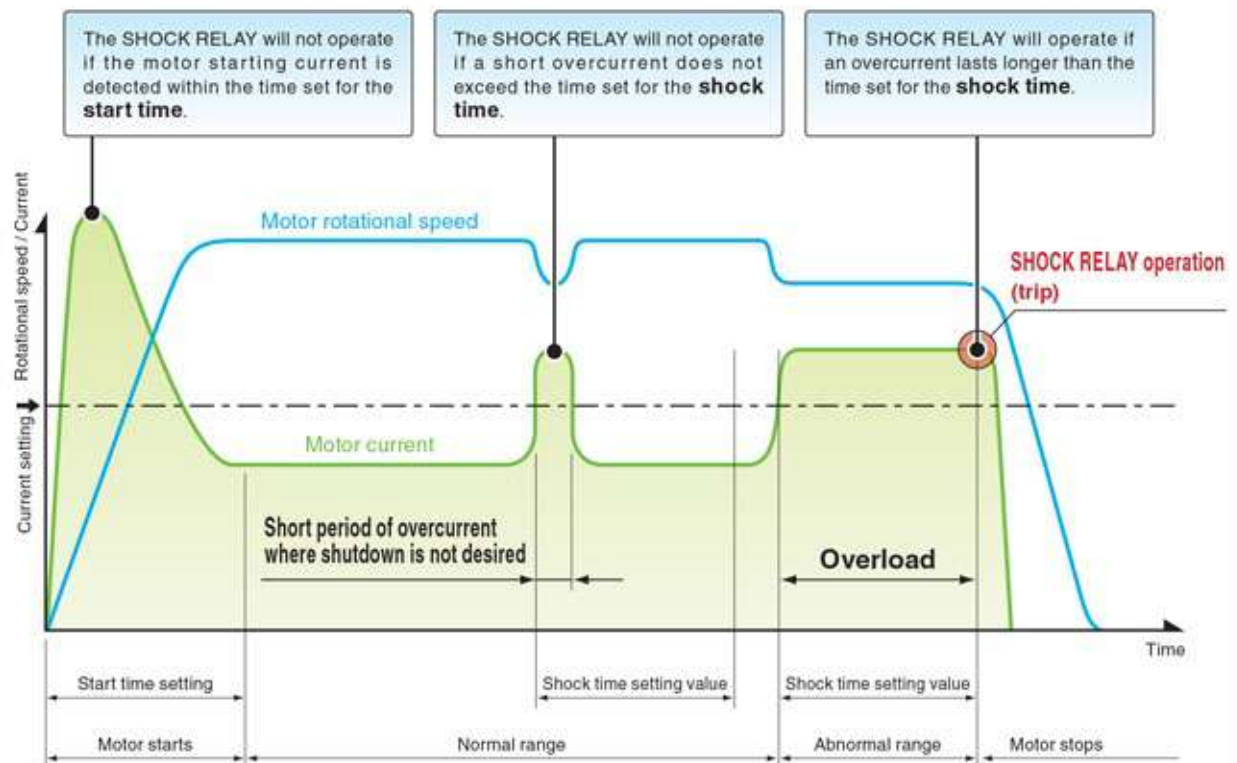

Model No.

T S B S B 0 5

SHOCK RELAY SB Series Frame No.

Various part names and functions



* Picture shows the SHOCK RELAY with the DIP switch cover removed.

Standard specifications

Model No.		TSBSB05	TSBSB10	TSBSB30	TSBSB60	TSBSB100	TSBSB200	TSBSB300
Item								
Current setting range		0.5 to 6 A	1 to 12 A	3 to 30 A	5 to 60 A	10 to 100 A	20 to 200 A	30 to 300 A
Time setting range	Start time	0.2 to 10s						
	Shock time	0.2 to 5s						
Current accuracy setting		±10% (Full scale)						
Operation power		24 to 240 V AC/DC ±10%, 50/60 Hz						
Maximum motor circuit voltage		600 V AC, 50/60 Hz						
Current detection		Two-phase CT system						
Display		Normal monitoring state: MON lamp is on Overcurrent monitoring state: OC lamp is on						
Output relay	Contact arrangement	1a1b						
	Contact rating	3 A, 250 V AC, $\cos\phi = 1$						
	Recommended current (high-frequency operation)	0.2 A or less, 250 V AC, $\cos\phi = 0.4$						
	Minimum applicable load	10 V DC, 10 mA						
	Operation selection	DIP switch selection set to SS: Excitation when normal, self-hold after trip; Selection set to SA: Excitation upon error, automatic reset after trip						
Operating environment	Life	80,000 times at contact rating load						
	Operating temperature	-20 to 60°C						
	Storage temperature	-30 to 70°C						
	Humidity	45 to 85% RH with no condensation						
	Altitude	2,000 m or less						
	Atmosphere	No dust or corrosive gas Pollution degree 3 or below when installed in control box						
Insulation resistance	Vibration	5.9 m/s ² or less						
	Between circuit and housing	10 MΩ or more (500 V DC Megger)						
Dielectric voltage	Between circuit and housing	2000 V AC, 60 Hz, for 1 minute						
	Between contacts	1000 V AC, 60 Hz, for 1 minute						
	Between circuits	2000 V AC, 60 Hz, for 1 minute						
Protection construction		IP20						
Material	Housing	Upper housing: PA6; Lower housing: PA66						
	Terminal cover	PA6						
Power consumption		2 W or less						
Mounting		35-mm DIN rail or mounting plate						
Estimated mass	Main unit (External CT only)	0.2 kg (0.5 kg)						

External dimensions

▶ Integrated CT type ◀

TSBSB05 / TSBSB10 / TSBSB30 / TSBSB60

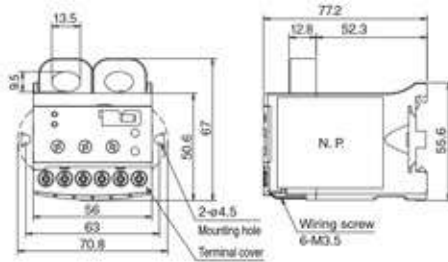

▶ Externally mounted CT type ◀

TSBSB100 / TSBSB200 / TSBSB300

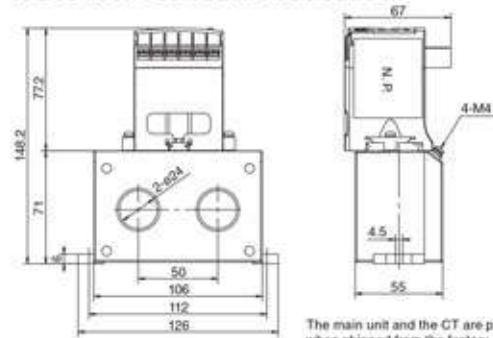

The main unit and the CT are pre-wired when shipped from the factory.

Basic connection diagram

▶ DIP switch selection set to SS ◀

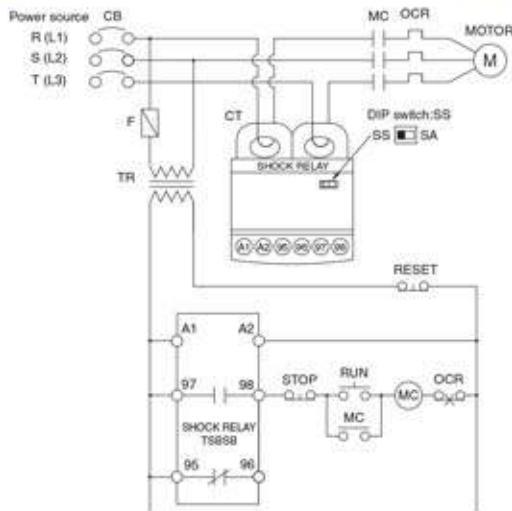

▶ DIP switch selection set to SA ◀

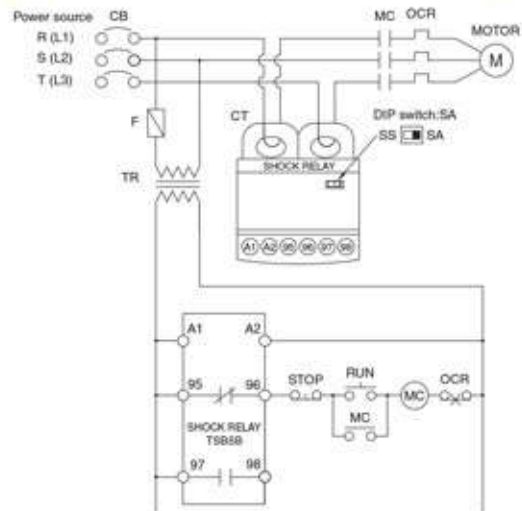

Notes: 1. Transformers (Tr) should be attached as necessary according to the operating power of the SHOCK RELAY.

In addition, the use of inverters or other harmonic noise generators may cause a malfunction. In such cases, make sure to install an isolation transformer.

2. Make sure that two of the three-phase wires routed to the motor pass through the two SHOCK RELAY CTs in the same orientation.

3. The coil capacity of the electromagnetic contactor (MC) to be connected to the output relay of the SHOCK RELAY should be less than 200 VA when ON and less than 20 VA during retention.

4. Be cautious of the DIP switch selection of the SHOCK RELAY when connecting.

CT wiring

Depending on the motor capacity, refer to the table on the right to decide the applicable SHOCK RELAY model No. and the number of wires passing through the CT.

To improve CURRENT volume setting accuracy, at least two wires are used in combination with smaller motor currents. In such instances as when the load factor of the motor is low, increase the number of wires as necessary.

It should be noted that, with two wires passing through, it's necessary to convert the current scale of the CURRENT volume.

(Example) With two wires passing through the CT, the CURRENT scale values should be halved before configuring the settings.

200 V AC motor		
Capacity (kW)	Applicable SHOCK RELAY model No.	Number of wires passing through CT
0.1	TSBSB05	4
0.2	TSBSB05	3
0.4	TSBSB05	2
0.75	TSBSB05	1
1.5	TSBSB10	1
2.2	TSBSB10	1
3.7	TSBSB30	1
5.5	TSBSB30	1
7.5	TSBSB60	1
11	TSBSB60	1
-	-	-
-	-	-
-	-	-

400 V AC motor		
Capacity (kW)	Applicable SHOCK RELAY model No.	Number of wires passing through CT
-	-	-
0.2	TSBSB05	4
0.4	TSBSB05	3
0.75	TSBSB05	2
1.5	TSBSB05	1
2.2	TSBSB05	1
3.7	TSBSB10	1
5.5	TSBSB30	1
7.5	TSBSB30	1
11	TSBSB30	1
15	TSBSB60	1
18.5	TSBSB60	1
22	TSBSB60	1

Safety and Control Devices **SAFCON**



From equipment protection devices like torque limiters, shock guards, and shock relays to control devices like torque keepers and shock monitors, Tsubaki's "SAFCON" safety and control devices provide your vital machinery with top-notch safety and improvements.



Safety Guide and Warranty



WARNING

This mark indicates a situation where incorrect handling may cause hazardous conditions, resulting in death or severe injury.

- When using any of the products described in this catalog, be sure to follow any applicable safety laws and regulations (such as the Labor Safety and Health Regulations).
- Follow the instructions below when installing, maintaining, or inspecting a product.
 1. Turn the power switch off.
 2. Do not store the device under equipment that may fall.
 3. Secure the movable parts of the equipment so as not to move.
 4. Wear clothing and protective gear suitable for the work.
- When performing a test operation or during periodic inspections, verify that the protective equipment is functioning properly.
- Because the SHOCK RELAY has certain requirements for Megger testing, follow the instruction manual when carrying out testing.
- Never perform work while the product is powered. Make sure the power is off before performing the work.
- **Failure to do so can result in electric shock.**
- SHOCK RELAY wiring, electrical operation, and maintenance and inspection should be performed only by qualified personnel with specialized knowledge.
- **Otherwise, fire, electric shock, and injury may occur.**
- Operate the SHOCK RELAY according to the manufacturer's instructions.
- **Failure to do so can result in electric shock or fire.**



CAUTION

This mark indicates a situation where incorrect handling may cause hazardous conditions, resulting in medium or slight personal injury or property damage.

- Ensure that the end user of the device receives the appropriate instruction manual. Also make sure that the contents of the manual are carefully read before use.
- In the event that an instruction manual is not available, use the device name and model number to request one from the distributor where you purchased the device or from our sales office.
- Do not rearrange the device's components or perform additional work in order to modify the device in any way.
- This device includes consumable parts (tantalum electrolytic capacitors, relays, etc.).
- Periodically check the product's functions and operations according to the instruction manual. If a function or operation is found to be inadequate, contact the distributor for repair.
- Do not use the device in a corrosive gas environment. Sulphidizing gases (SO₂, H₂S) can especially corrode the copper and copper alloy used on PCBs and parts, resulting in a malfunction.
- Periodically clean the device to prevent overheating due to dust or other substances as this may cause a fire.
- When disposing of the device, treat it as industrial waste.
- The device details described in this catalog are intended primarily for model selection. Before using the device, read the instruction manual thoroughly, and ensure the device is used correctly.

Warranty: Tsubaki E&M Co., hereinafter referred to as "Seller" Customer, hereinafter referred to as "Buyer"
Goods sold or supplied by Seller to Buyer, hereinafter referred to as "Goods"

1. Warranty period without charge

Effective 18 months from the date of shipment or 12 months from the first use of Goods, including the installation of the Goods to the Buyer's equipment or machine - whichever comes first.

2. Warranty coverage

Should any damage or problem with the Goods arise within the warranty period, given that the Goods were operated and maintained according to the instructions provided in the manual, the Seller will repair and replace at no charge once the Goods are returned to the Seller.

This warranty does not include the following:

- 1) Any costs related to removal of Goods from the Buyer's equipment or machine to repair or replace parts.
- 2) Cost to transport Buyer's equipment or machines to the Buyer's repair shop.
- 3) Costs to reimburse any profit loss due to any repair or damage and consequential losses caused by the Buyer.

3. Warranty with charge

Seller will charge for any investigation and repair of Goods caused by:

- 1) Improper installation by failing to follow the instruction manual.
- 2) Insufficient maintenance or improper operation by the Buyer.
- 3) Incorrect installation of the Goods to other equipment or machines.
- 4) Any modifications or alterations of Goods by the Buyer.
- 5) Any repair by engineers other than the Seller or those designated by the Seller.
- 6) Operation in an environment not specified in the manual.
- 7) Force Majeure or forces beyond the Seller's control such as natural disasters and injustices inflicted by a third party.
- 8) Secondary damage or problems incurred by the Buyer's equipment or machines.
- 9) Defective parts supplied or specified by the Buyer.
- 10) Incorrect wiring or parameter settings by the Buyer.
- 11) The end of life cycle of the Goods under normal usage.
- 12) Losses or damages not liable to the Seller.

4. Dispatch service

The service to dispatch a Seller's engineer to investigate, adjust or trial test the Seller's Goods is at the Buyer's expense.

The logos and product names used in this catalog are either trademarks or registered trademarks of Tsubakimoto Chain Co. or the Tsubaki Group in Japan and other countries.

TSUBAKIMOTO CHAIN CO.

Headquarters

Nakanoshima Mitsui Building
3-3-3 Nakanoshima, Kita-ku
Osaka, 530-0005, Japan
Phone : +81-6-6441-0011
URL : <http://tsubakimoto.com>

Chain & Power Transmission Sales

1-3 Kannabidai, 1-chome
Kyotanabe,
Kyoto, 610-0380, Japan
Phone : +81-774-64-5022

Group companies

NORTH and SOUTH AMERICA

U.S. TSUBAKI POWER TRANSMISSION, LLC
301 E. Marquardt Drive, Wheeling, IL 60090, U.S.A.
Phone : +1-847-459-9500
URL : <http://ustsubaki.com/>

TSUBAKI of CANADA LIMITED
1630 Drew Road, Mississauga, Ontario, L5S 1J6, Canada
Phone : +1-905-676-0400
URL : <http://tsubaki.ca>

TSUBAKI BRASIL EQUIPAMENTOS INDUSTRIAIS LTDA.
R. Pamplona, 1018, CJ. 73/74, Jd. Paulista
CEP 01405-001, São Paulo, S.P. Brazil
Phone : +55-11-3253-5656
URL : <http://tsubaki.ind.br>

EUROPE

TSUBAKIMOTO EUROPE B.V.
Aventurin 1200, 3316 LB Dordrecht, The Netherlands
Phone : +31-78-620-4000
URL : <http://tsubaki.eu>

TSUBAKIMOTO U.K. LTD
Osier Drive, Sherwood Park, Annesley, Nottingham
NG15 0DX, United Kingdom
Phone : +44-1623-686-700
URL : <http://tsubaki.eu>

TSUBAKI DEUTSCHLAND GmbH
ASTO Park Oberpflaffenhofen, Friedrichshafener Straße 1
D-82205, Gilching, Germany
Phone : +49-8105-7307100
URL : <http://tsubaki.de/>

OOO "TSUBAKI KABELSCHLEPP"
Prospekt Andropova 18, Building 6
115432 Moscow, Russia
Phone : +7-499-418212
URL : <http://kabelschlepp.ru/>

ASIA and OCEANIA

TAIWAN TSUBAKIMOTO CO.
No. 33, Lane 17, Zhong North Road
Gueishan Township Taoyuan County Taiwan R.O.C.
Phone : +886-3-3293827/8/9
URL : <http://tsubakimoto.com.tw>

TSUBAKIMOTO CHAIN (SHANGHAI) CO. LTD.
Room 601, Urban City Centre, 45 Nanchang Road
Huangpu District, Shanghai 2000020, People's Republic of China
Phone : +86-21-5396-6651/2
URL : <http://tsubaki.cn/>

TSUBAKI INDIA POWER TRANSMISSION PVT. LTD.
Chandrika Chambers No.4, 3rd Floor, Anthony Street
Royapettah, Chennai, Tamil Nadu 600014, India
Phone : +91-44-4231-5251
URL : <http://tsubaki.in/>

TSUBAKIMOTO SINGAPORE PTE. LTD.
25 Gul Lane, Jurong, Singapore 629419
Phone : +65-6861-0422/3/4
URL : <http://tsubaki.sg>

TSUBAKIMOTO SINGAPORE PTE. LTD.
VIETNAM REPRESENTATIVE OFFICE
H&H Building 8F, 209 Hoàng Văn Thụ
Phủ Nhuận District, Hồ Chí Minh City, Vietnam
Phone : +84-8-3999-0131/2
URL : <http://tsubaki.net.vn/>

PT. TSUBAKI INDONESIA TRADING
Wisma 46 - Kota BNI, 24th Floor, Suite 24.15
Jl. Jend. Sudirman, Kav. 1, Jakarta 10220, Indonesia
Phone : +62-21-571-4230/31
URL : <http://tsubakimoto.co.id/>

TSUBAKI POWER TRANSMISSION (MALAYSIA) SDN. BHD.
No. 22, Jalan Astaka U8/84A,
Bukit Jelutong Industrial Park
Section U8, 40150 Shah Alam, Selangor, Malaysia
Phone : +60-3-7859-8585
URL : <http://tsubaki.sg>

TSUBAKI AUSTRALIA PTY. LTD.
Unit E, 95-101 Silverwater Road
Silverwater NSW 2128, Australia
Phone : +61-02-9704-2500
URL : <http://tsubaki.com.au>

TSUBAKI AUSTRALIA PTY. LTD.
NEW ZEALAND BRANCH
2 Kalmia Street, Ellerslie, Auckland 1051, New Zealand
Phone : +64-275-082-726
Phone : <http://tsubaki.com.au>

TSUBAKIMOTO (THAILAND) CO. LTD.
388 Exchange Tower, 19th Floor Unit 1902
Sukhumvit Road, Klongtoey, Bangkok 10110, Thailand
Phone : +66-2-262-0667/8/9
URL : <http://tsubaki.co.th>

TSUBAKIMOTO KOREA CO., LTD.
#1004/1005 East Wing, Hanshin Intervalley 24, 707-34
Yeoksam-dong, Gangnam-gu, Seoul, Korea
Phone : +82-02-2163-0311
URL : <http://tsubakimoto.com>

Distributed by: