

Content

Introduction to Shock Relays	Page F-2
"SS" Series Analogue Shock Relays	F-3 - F-5
"SD" Series Digital Shock Relays	F-6 - F-10
Introduction to Power-Lock	F-11
AS Power-Lock Construction/Selection/Installation/Removal	F-12 - F-16
AS Inch Series Power-Lock Specification Table	F-17
AS Metric Series Power-Lock Specification Table	F-18
AD Power-Lock Construction/Selection/Installation/Removal	F-19 - F-20
AD Metric Series Power-Lock Specification Table	F-21
KE Power-Lock Construction/Selection/Installation/Removal	F-22 - F-23
KE Inch Series Power-Lock Specification Table	F-24
AE Power-Lock Construction/Selection/Installation/Removal	F-25 - F-26
AE Metric Series Power-Lock Specification Table	F-27
EL Power-Lock Construction/Selection/Installation/Removal	F-28 - F-29
EL Metric Series Power-Lock Specification Table	F-30 - F-31
EL Metric Series Power-Lock Hub Diameter Selection Tables	F-32 - F-33
TF/SL/EF/RE Metric Series Power-Locks	F-34
One-Touch Inspection Door®	F-35 - F-36
Pro-Align® Laser Alignment System	F-37
Warning Statement	F-38
Index	F-39
Terms & Conditions	F-40 - F-42



Introduction to Shock Relays

At Tsubaki, our commitment is to bring you the highest value in the industry today. Period. And as a full line supplier of power transmission products this commitment extends to our complete line of Shock Relay products as well.

Protect your equipment and investment with Tsubaki shock relays and external current transformers. Unexpected shock loads can damage chains, drives, gears, turbines – the entire mechanical assembly. That means high maintenance, costly repairs, and expensive downtime.

Simply put, when the shock relay detects a problem, it shuts down the line – quickly, safely and securely. That means big savings in both time and money.

After the problem is corrected, the shock relay is reset at the touch of a button. No tear down is required. That means improved efficiency and reduced downtime.

And it's all part of the Tsubaki Advantage: reliable premium products that don't just perform, they outperform the competition. All the while saving you money.



Model Numbers: TSBSS05, TSBSS30 and TSBSS60

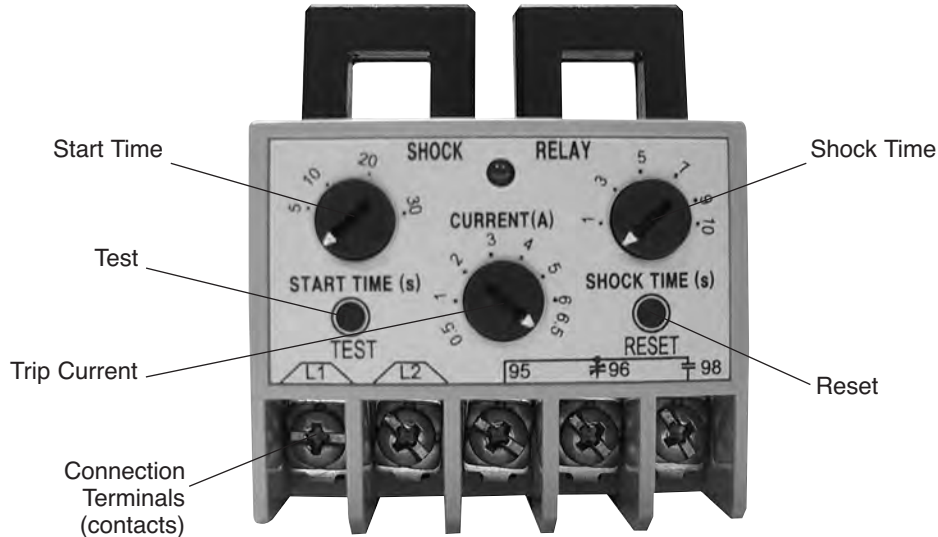

Explanation of Terms

Start Time

During startup, the current draw of a motor is greater than the running current. In order to prevent the shock relay from engaging during startup, the start time of the shock relay is adjustable from 0.2 seconds to 30 seconds. The shock relay will only trip when the current draw of the motor exceeds the trip current and when the start time is reached.

Test

The test button simulates a current overload.

Trip Current

The trip current level is user adjustable and varies according to the shock relay model selected - see specification chart on the following page for complete details. When the actual current level exceeds the preset current (outside of the shock time range), the shock relay will trip.

Shock Time

The shock time feature allows the current overload time to be set. The shock time is adjustable from 0.2 seconds to 10 seconds. The shock relay will only trip when the current draw of the motor exceeds the trip current and when the shock time is exceeded.

Reset

The reset button will reset the shock relay after a current overload.

Connection Terminals (contacts)

There are 5 connection terminals:

L1 & L2: These terminals are used to provide power (from 90VAC to 240VAC) to the shock relay.

95, 96 & 98: These terminals provide output from the shock relay. The application - such as a motor - can be wired into these terminals. When the shock relay trips, the circuit opens and the application stops.

"SS" Series Shock Relays Specifications

SPECIFICATIONS / MODEL	TSBSS05	TSBSS30	TSBSS60
Built-in or External Current Transformer	Built-in	Built-in	Built-in
Motor Horsepower at 200 VAC	0.08hp - 1.5hp	2hp - 7.5hp	10hp - 15hp
Motor Horsepower at 400 VAC	0.27hp - 3hp	5hp - 15hp	20hp - 30hp
Load Current Setting Range	0.5A - 5A	3A - 30A	5A - 60A
Trip Output Relay - contact rating	3A load	3A load	3A load
Trip Output Relay - status	Normally Loaded	Normally Loaded	Normally Loaded
Start Time Setting Range	0.2 - 30 sec.	0.2 - 30 sec.	0.2 - 30 sec.
Shock Time Setting Range	0.2 - 10 sec.	0.2 - 10 sec.	0.2 - 10 sec.
Input Voltage	90VAC to 240VAC 60HZ	90VAC to 240VAC 60HZ	90VAC to 240VAC 60HZ
Test Function Built-in	Yes	Yes	Yes
Mounting available for 35mm DIN rail or panel	Yes	Yes	Yes
Operating Temperature Range	-4°F - 158°F	-4°F - 158°F	-4°F - 158°F
CUL Approval	Yes	Yes	Yes

Tsubaki Shock Relays can be used in applications up to 600 volts.

"SS" Series Shock Relays Dimensions (mm)

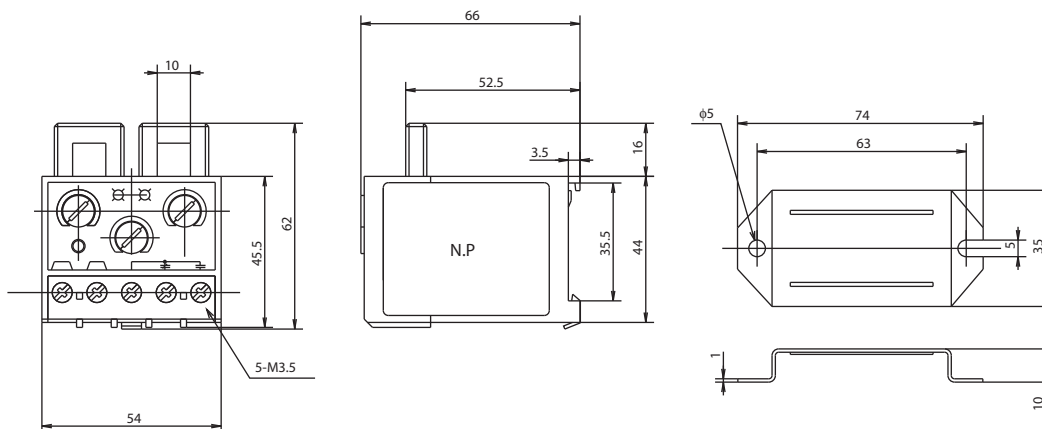

"SS" Series Shock Relays Typical Wiring Diagram

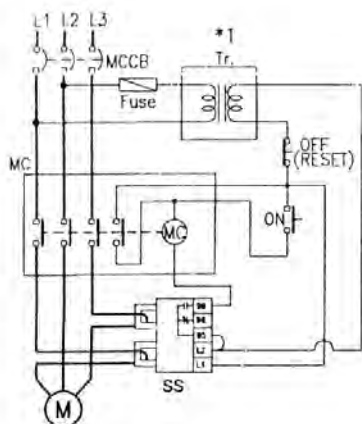

- | | |
|-------------------------------|-------------------------|
| CB: Circuit Breaker | Off: Stop Switch |
| MC: Magnetic Contactor | M: Motor |
| On: Start Switch | Tr: Transformer |

Section F

“SS” Series Shock Relay Plus External Current Transformer

Model Numbers: TSBSS100, TSBSS200 and TSBSS300

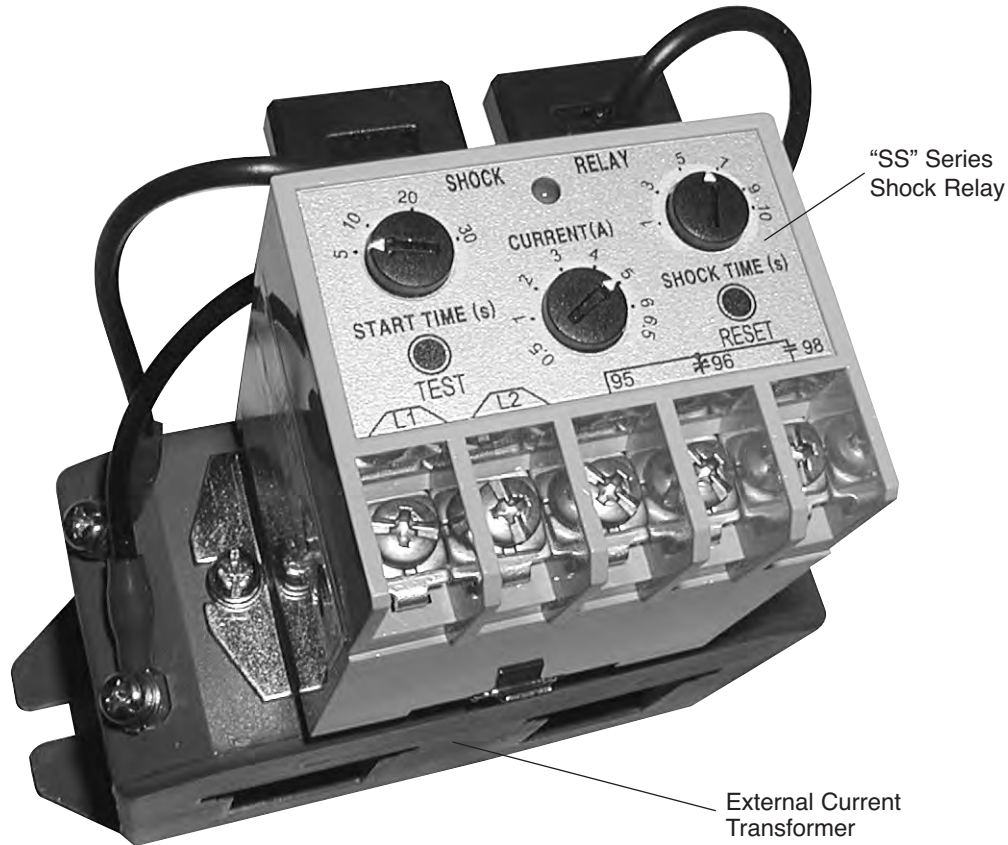

The external current transformer is wired together with the “SS” series shock relay to provide overload protection for applications using larger motors – typically over 100A. See specification chart below for more details.

“SS” Series Shock Relays & Included External Current Transformer Specifications

SPECIFICATIONS / MODEL	TSBSS100	TSBSS200	TSBSS300
Shock Relay Model	TSBSS05	TSBSS05	TSBSS05
External Current Transformer Model	TSB2CT100	TSB2CT200	TSB2CT300
Motor Horsepower at 230 VAC	20hp - 25hp	30hp - 50hp	60hp - 100hp
Motor Horsepower at 460 VAC	40hp - 60hp	75hp - 120hp	150hp - 175hp
Load Current Setting Range	10A - 100A	20A - 200A	30A - 300A
Trip Output Relay - contact rating	3A load	3A load	3A load
Trip Output Relay - status	Normally Loaded	Normally Loaded	Normally Loaded
Start Time Setting Range	0.2 - 30 sec.	0.2 - 30 sec.	0.2 - 30 sec.
Shock Time Setting Range	0.2 - 10 sec.	0.2 - 10 sec.	0.2 - 10 sec.
Input Voltage	90VAC to 240VAC 60HZ	90VAC to 240VAC 60HZ	90VAC to 240VAC 60HZ
Test Function Built-in	Yes	Yes	Yes
Mounting available for 35mm DIN rail or panel	No	No	No
Operating Temperature Range	-4°F - 158°F	-4°F - 158°F	-4°F - 158°F

Tsubaki Shock Relays can be used in applications up to 600 volts.

Section F

Model Numbers: TSBSD10 and TSBSD60

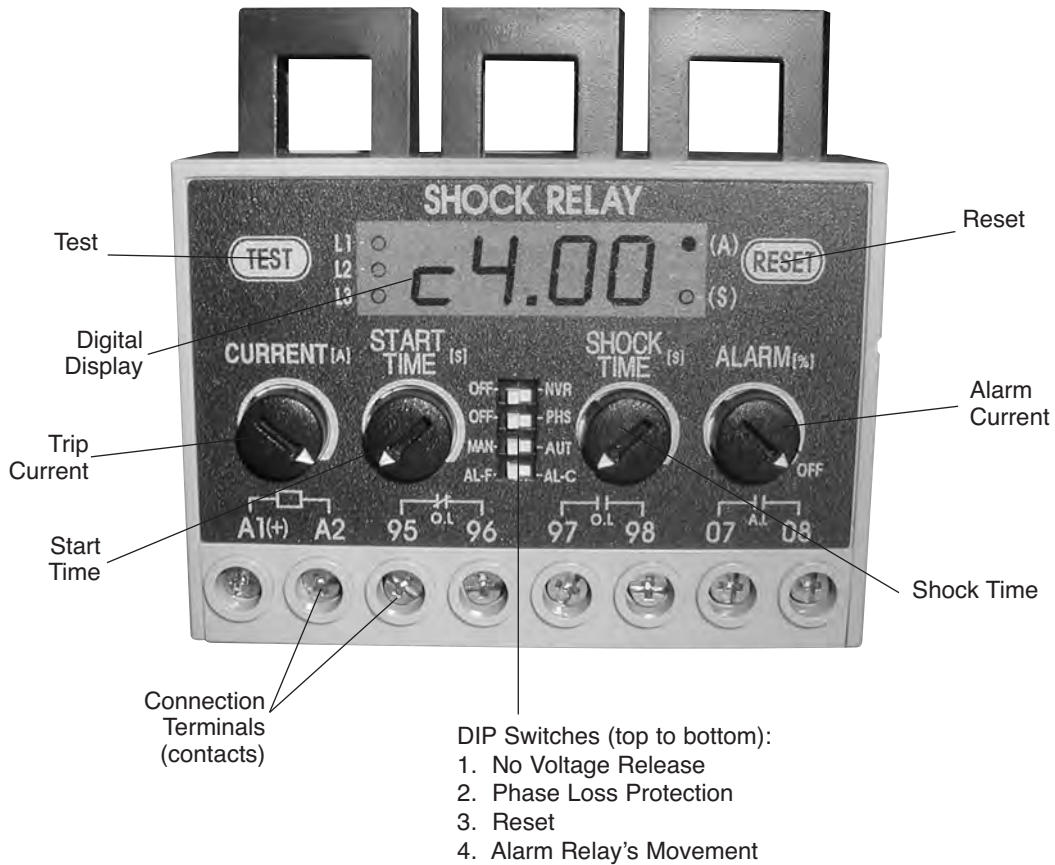

Explanation of Terms

Digital Display

The digital display indicates the actual current, trip level, time and the trip code.

Test

The test button simulates a current overload.

Reset

The reset button will be used to reset the shock relay after a current overload.

Trip Current

The trip current level can be set by the operator. When the actual current level exceeds the preset current (outside of the shock time range), the shock relay will trip.

Explanation of Terms (Continued)

Start Time

During startup, the current draw of a motor is greater than the running current. In order to prevent the shock relay from engaging during startup, the start time of the shock relay is adjustable from 0.3 seconds to 12 seconds. The shock relay will only trip when the current draw of the motor exceeds the preset current and when the start time is met.

Shock Time

This feature allows the shock relay to ignore normal machine fluctuations, yet react when a true problem develops. The shock time is adjustable from 0.3 seconds to 3 seconds. The shock relay will only trip when the current draw of the motor exceeds the trip current and when the shock time is met.

Alarm Current

An alarm can be connected to the terminals on the front panel of the shock relay. The alarm current can be set to between 50% and 100% of the trip current level. This allows for a pre-alarm warning when the current draw is approaching the preset current level. If an alarm is not being used, the alarm current setting can be set to the “off” position.

DIP Switches

The shock relay has 4 DIP Switches that toggle between two settings and that allow the shock relay to be configured for a particular application.

The DIP switches are:

- 1: “No Voltage Release” (on/off)** This switch changes the status of contacts 95-96 and 97-98. For example, in left-hand position contacts 95-96 are normally closed; and in the right-hand position, contacts 95-96 are normally open. This adds flexibility to aid installation.
- 2: “Phase Loss Protection” (on/off)** When set to the “on” mode (right hand position), the connected motor will shut down if one of the three phases of the motor drops out. The motor will also shut down if there is a phase imbalance. The “off” mode (left hand position) disables this feature.
- 3: “Reset” (manual/automatic)** When set to the “manual” mode, if the shock relay trips due to current overload or phase failure, the shock relay must be reset manually by pushing the “reset” button. In the “automatic” mode, the shock relay automatically resets one second after the current overload causes it to trip. Also in the “automatic” mode, the shock relay must be manually reset after phase failure causes it to trip.
- 4: “Alarm Relay’s Movement” (flicker/continuous)** This feature works with the alarm current setting. In the left-hand position, “flicker” mode, when the alarm current setting is met, the alarm will activate by blinking/flickering one time per second. Essentially this is a “pre-alarm” to indicate the potential for a problem. In this mode, the motor will continue to operate. When the problem is corrected and when the current drops to normal, the alarm will stop. If the situation is not corrected and the shock relay trips, (shutting down the application) the alarm will stay on, but now blinks/flickers at a rate of two-times per second. In the right-hand position, “continuous” mode, the alarm will be activated when the motor current is between the pre-alarm set point and the overload trip point. If the current drops below the setting or if the shock relay trips, the alarm will turn off.

Explanation of Terms (Continued)

Connection Terminals (contacts)

There are 4 sets (pairs) of connection terminals.

A1 & A2

These terminals are used to provide power to the unit.

95 & 96

These terminals are for the trip output relay and are “normally closed”. The application - such as a motor - could be wired into these terminals. When the shock relay trips, the circuit opens and the application stops.

97 & 98

The circuit connected to these terminals is “normally open”. A warning device such as an alarm or light could be wired into these terminals. When the shock relay trips, the circuit closes and the warning device is activated.

07 & 08

These terminals are used to connect an alarm. This circuit is “normally open”. When the alarm set point is reached, the circuit closes and then the alarm is activated. This could be considered a pre-alarm to indicate the potential for a problem should the current increase further.

“SD” Series Digital Display Shock Relays Specifications

SPECIFICATIONS / MODEL	TSBSD10	TSBSD60
Built-in or External Current Transformer	Built-in	Built-in
Motor Horsepower at 230 VAC	0.1hp - 3hp	5hp -15hp
Motor Horsepower at 460 VAC	0.2hp - 5hp	7hp - 30hp
Load Current Setting Range	0.5A - 10A	5A - 60A
Trip Output Relay - contact rating	3A load	3A load
Trip Output Relay - status	DIP switch #1 can be set to "normally closed" or "normally open"	
Alarm Output Relay - setting level	50% - 100% of load current setting	50% - 100% of load current setting
Alarm Output Relay - contact rating	3A load	3A load
Alarm Output Relay - status	Loaded 3 seconds after exceeding preset alarm current level	
Open phase, reverse phase, phase unbalance	DIP switch #2 can be set to enable or disable phase failure protection.	
Start Time Setting Range	0.2 sec. - 12 sec.	0.2 sec. - 12 sec.
Shock Time Setting Range	0.3 sec - 3 sec.	0.3 sec - 3 sec.
Input Voltage	85VAC - 250VAC, 50/60Hz, 85V DC - 250V DC	
Test Function Built-in	Yes	Yes
Mounting available for 35mm DIN rail or panel	Yes	Yes
Operating Temperature Range	14°F - 122°F	14°F - 122°F

Tsubaki Shock Relays can be used in applications up to 600 volts.

"SD" Digital Shock Relay Dimensions (mm) & Typical Wiring Diagram

Model Numbers: TSB3CT100, TSB3CT200 and TSB3CT300

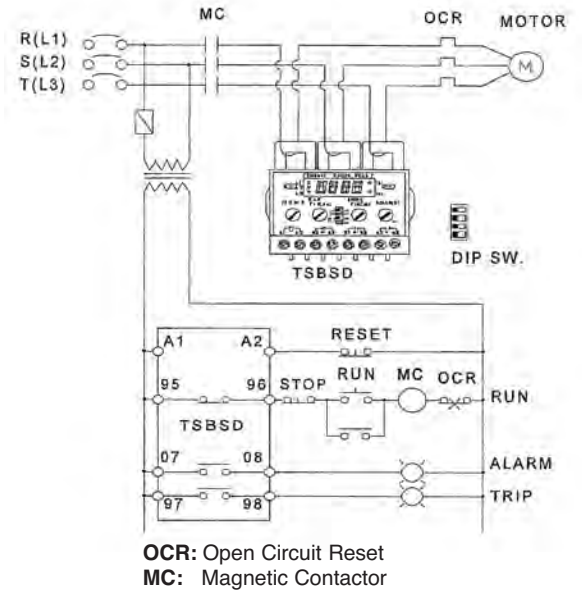
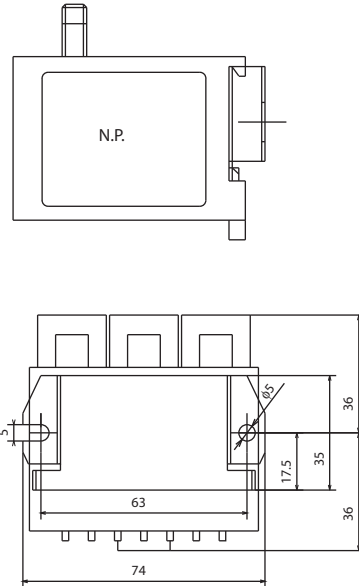
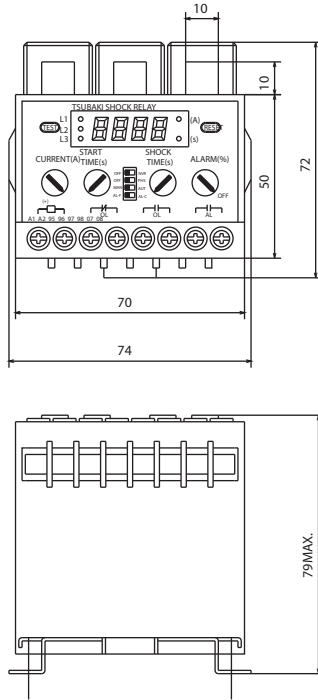

"SD" Series External Current Transformer

Connection Terminals

Installation Screw Holes

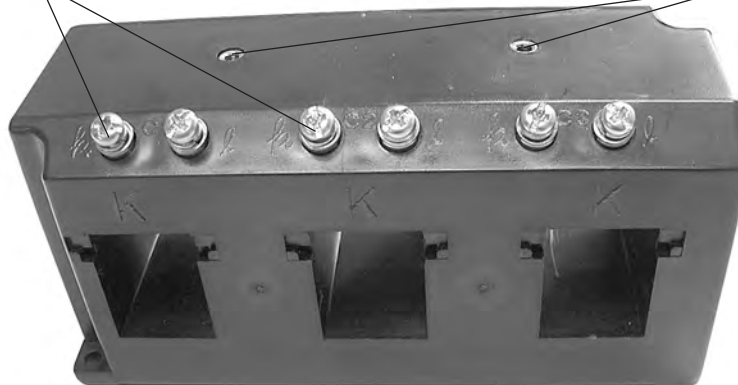

Explanation of Terms

Installation Screw Holes

The digital shock relay is installed by threading the screws into the screw holes on the external current transformer.

Connection Terminals

Using the wires included with the external current transformer, loop the wires through the holes on the top of the digital shock relay and attach to the corresponding connection terminals.

"SD" Series External Current Transformer Specifications
Specifications for the External Current Transformer only

SPECIFICATIONS / MODEL	TSB3CT100	TSB3CT200	TSB3CT300
Built-in or External Current Transformer	External	External	External
Motor Horsepower at 230 VAC	20hp - 25hp	30hp - 50hp	60hp - 100hp
Motor Horsepower at 460 VAC	40hp - 60hp	70hp - 120hp	150hp - 175hp
Load Current Setting Range	5A - 100A	10A - 200A	15A - 300A
Mounting available for 35mm DIN rail or panel	No	No	No
Operating Temperature Range	14°F - 122°F	14°F - 122°F	14°F - 122°F

Tsubaki Shock Relays can be used in applications up to 600 volts.

"SD" Series External Current Transformer Dimensions (mm)

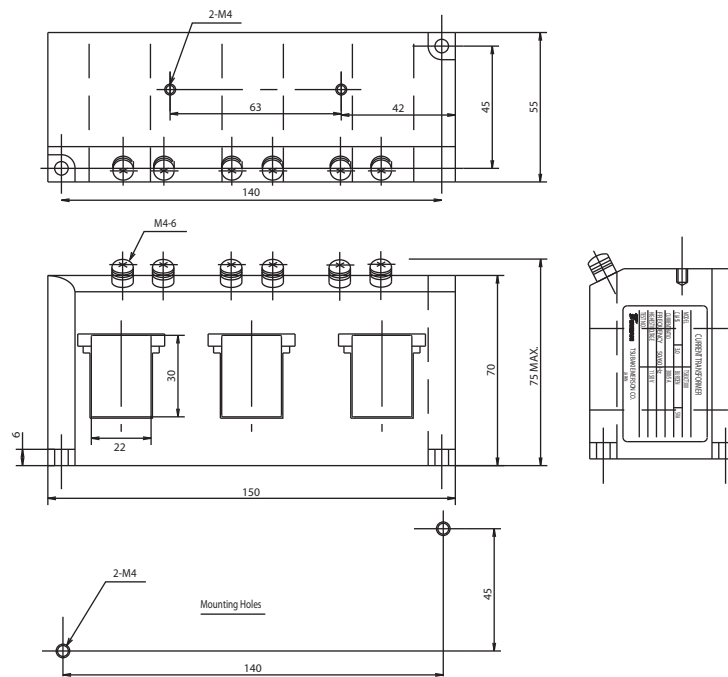

Digital Display Shock Relay & External Current Transformer

Installation Example

TSBSD10 Digital Shock Relay & TSB3CT100
External Current Transformer



The traditional and popular "industry standard", the keyed mount has a number of widely acknowledged limitations. In a keyed connection the clearances that must exist between the component hub, shaft, keyway, and key allow for metal-to-metal contact leading to fretting and corrosion. The poor fit also allows "backlash" to occur during the starting, stopping and transmitting power during normal operation. The process of machining the keyway into the shaft is tedious, permanent and expensive. It also reduces the strength and amount of torque a given shaft size can transmit. Another popular connection system, the interference fit also has limitations. Interference fits or welds prevent the operator from being able to easily remove the shaft from the hub for maintenance or replacement.

Tsubaki has been a leader within the power transmission industry in the quest to find a better way to connect components to shafts.

The Tsubaki Power-Lock is a well-engineered, adjustable and affordable device that solves engineering and maintenance difficulties associated with other connection alternatives. Tsubaki Power-Lock is a shaft-to-hub friction connection that relies on concentric surface pressure to affix gears, sprockets, and other drive components to a motor-driven shaft. Power-Lock improves the connection of a drive component to a shaft. It helps to eliminate problems with keyway connections and limitations for QD and tapered bushings. This frictional, keyless system enables transmission of high-torque and axial loads, and accommodates reversing, dynamic or shock loading. Tsubaki Power-Locks can be used in such common applications as the connection of timing pulleys, sheaves, conveyor pulleys, indexing applications, sprocket, gears, cams, levers, motors and hydraulics, clutches and brakes and flange couplings. Power-Lock is available in both Inch and Metric sizes in a variety of styles.

The Power-Lock allows for easy attachment of shaft to hub without time and money spent on machining or extra assembly labour. Power-Lock connects hubs solidly to shafts, using a keyless mechanical interference fit to transmit torque or to withstand axial thrust. This mechanical interference fit utilizes screw tension in the Power-Lock, converted into radial pressure. This pressure expands the Power-Lock to eliminate the gap between the hub and the shaft. The Power-Lock uses the friction bond between the Power-Lock and the shaft/hub to create a zero backlash connection. This connection is easily releasable to remove the mechanical interference fit.

The contact pressures created using a Power-Lock can be greater than traditional interference fit pressures, allowing for more torque to be transmitted or shorter hubs to be used. The easy installation also allows the hub to be positioned more accurately on the shaft, and can facilitate angular timing of the hub.



AS type Power-Locks are our most popular style. They can be assembled and disassembled frequently so that maintenance or replacement of worn hubs is simple and easy as compared to other methods. They are easy to install, adjust or remove, but are not self-centering. A precentering hub section is usually required. The Tsubaki AS Power-Lock uses an inner, collet-like, sleeve with a tapered O.D. and an outer sleeve with a tapered I.D. The tapers are identical, but opposing to one another. The inner sleeve fits around the shaft while the outer sleeve fits inside the hub bore of the component to be mounted, such as a pulley, gear, chain sprocket or other component. Upon tightening the loading mechanism, the bolts force the inner sleeve to squeeze onto the shaft and the outer sleeve to expand outward against the component hub bore. This mechanical shrink fit resists shock and torque reversals eliminating key wallowing, backlash and fretting corrosion associated with a keyed mount. The AS Power-Lock allows a given shaft size to transmit more torque than if it had a keyway, or both the shaft and peripheral components can be downsized reducing weight and cost. With a keyless connection, the gripping stress is evenly distributed 360° around the O.D. of the shaft and the I.D. of the component hub bore instead of being concentrated at the key and keyway. These units are most commonly used on applications in general engineering to transmit high torques and axial loads utilizing larger machining tolerances. AS Power-Locks are available in inch and metric sizes and also in stainless steel.



Construction

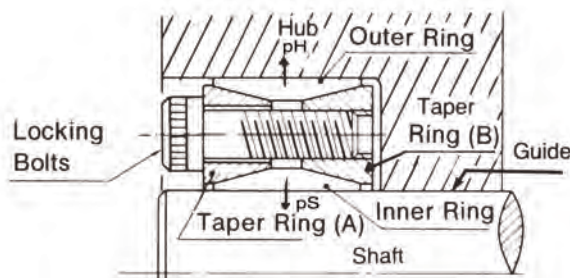

The Power-Lock is made up of five parts: taper ring (A), taper ring (B), outer ring, inner ring, and locking bolts. Locking is achieved by tightening the bolts.

Selection Guide:

1. a) Determine the required maximum torque (MtC) to be transmitted:

$$\text{Torque MtC} = \frac{5252 \times \text{HP}}{\text{RPM}} \quad (\text{ft-lb})$$

b) If combined torsional and axial loads are to be transmitted, calculate the resulting torque as follows:

$$M_{t \text{ res}} = \sqrt{\text{MtC}^2 + \left(\frac{F \times d}{24}\right)^2} \leq M_t$$

Where:

Mt res = resultant torque to be transmitted

MtC = actual or maximum torque to be transmitted (ft-lb). This value is calculated in step 1 a) above.

F = axial load/thrust to be transmitted (lbs)

d = shaft diameter (inches)

Mt = maximum transmissible torque (ft-lb) of the Power Lock as specified in the AS Power-Lock specification tables.

2. Select a Power-Lock for the shaft diameter (d) from the AS Power-Lock specification tables in this catalogue and verify that the corresponding maximum transmissible torque (Mt) meets the torque requirement that was calculated in step 1 a) above. If torque is the primary requirement, select the necessary torque (Mt) from the same specification tables and determine the corresponding shaft diameter (d).

Note: Required peak torque should never exceed specified transmissible torque (Mt).

To increase transmissible torque (Mt):

Install 2 or 3 Power-Locks in series, increasing transmissible torque as follows:

- with 2 Power-Locks: $M_{\text{trans}} = 2 \times M_t$

- with 3 Power-Locks: $M_{\text{trans}} = 3 \times M_t$

The hub must be long enough to accommodate the assemblies.

3. Determine the recommended minimum hub outside diameter (D_N) for the Power-Lock selected from the specification tables (which show the D_N for material with a yield point of 32,000 p.s.i.) For other yield point materials, calculate the hub outside diameter (D_N) by using the following equation:

$$D_N \geq D \times \sqrt{\frac{YP + (K_3 \times pH)}{YP - (K_3 \times pH)}} \quad (\text{inches or mm})$$

Where

D = Outer diameter of the Power-Lock and hub counter bore inside diameter (inches or mm).

YP = yield point of hub material (p.s.i. or MPa)

pH = Contact pressure between the Power-Lock and hub bore. See specification tables (p.s.i. or MPa).

K₃ = 0.6 (one Power-Lock)

K₃ = 0.8 (2 or 3 Power-Locks in series)

See Hub layout diagram on next page for more detail on value of K₃

Note: Use either all imperial values (inches/p.s.i.) or all metric values (mm/MPa) when calculating the value of D_N.

4. Verify that the hub length (B) is adequate for the selected Power-Lock; see Example below.
5. Check the applicable machining tolerance for the shaft and hub bore in the specification tables. A surface finish of 125 micro-inches for shafts and bores is generally adequate.

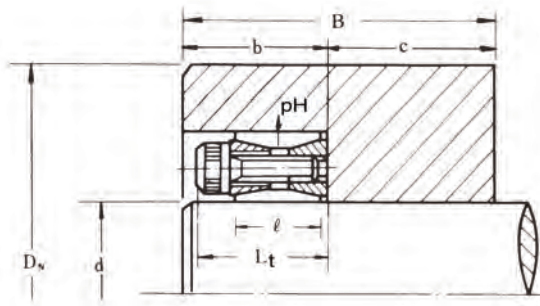

Fig. 1 (Single Power-Lock)
where $B \geq 2\ell$

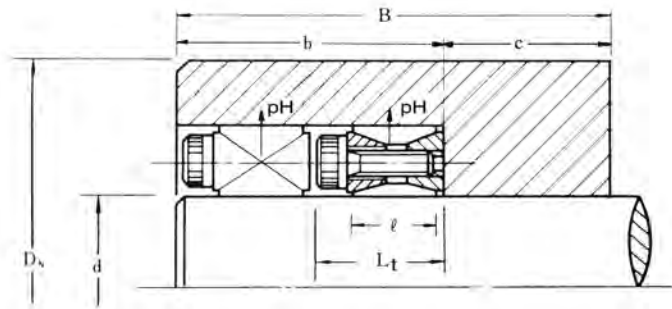

Fig. 2 (Multiple Power-Locks)
 $B \geq n \cdot 2L_t$
where n = number of Power-Locks
and where $2 \leq n \leq 4$
 $K_3=0.8$

EXAMPLE

A sprocket is to be mounted on a 1.50" shaft capable of transmitting a peak torque of 400 ft-lb. The sprocket is made of 1144 steel with a yield point of 56,000 p.s.i. Select the proper Power-Lock and determine the required hub dimensions and proper machining tolerances.

- a. The shaft diameter (d) is specified at 1.50".
- b. The AS Power-Lock specification tables indicate that a 1.5" Power-Lock is capable of transmitting a torque (Mt) of 658 ft-lb, which is more than the required amount of torque (400 ft-lb) given in this example. Select the PL 1 1/2 Power-Lock.
- c. Use the formula in step 3 in the Selection Guide on the previous page, to determine that the selected PL 1 1/2 Power-Lock requires a minimum hub outer diameter (D_N) of 3.03" based on Y.P. 56,000 psi hub material.
- d. The hub length (B) shown in figure 1 should be $\geq 2 \times \ell$. The specification table for AS Power Lock PL 1 1/2 indicates that $\ell = 0.709$ " therefore, $B \geq 2 \times 0.709 \geq 1.418$
- e. According to the AS Power-Lock specification tables, the machining tolerances for the selected AS Power-Lock are as follows:
shaft (d): 1.50" +.000/-0.0015"
- f. Order the following assembly:
Size 1 1/2
AS Inch: PL 1 1/2

Installation

1. Verify that all contact surfaces, including the screw threads and screw head bearing surfaces, are clean and lightly oiled.

Note: Do NOT use Molybdenum Disulfide, "Molykote" or any other similar lubricants.

2. Slide the Power-Lock onto the shaft and into the hub bore, aligning them as required.

3. Tighten the locking screws gradually in the sequence illustrated in Figure 1 below. The tightening sequence is as follows:

- a) Hand-tighten 3 or 4 equally spaced locking screws until they make contact. Align and adjust the connection.
- b) Hand-tighten and take up all remaining locking screws.
- c) Use a torque wrench to tighten the screws further to approximately one-quarter the specified torque (M_A - as found in the AS Power-Lock specification tables).
- d) Increase the tightening torque to 1/2 of M_A .
- e) Finally, use the torque wrench to tighten the screws to the full tightening torque (M_A).
- f) Verify that the screws are completely tight by applying the specified tightening torque (M_A).

Notes:

- i) Even tightening is best accomplished by turning each screw in increments of approximately 90° .

Fig. 1: Tightening Sequence For Locking Screws.
(This is only an example - other number of locking screws is possible)

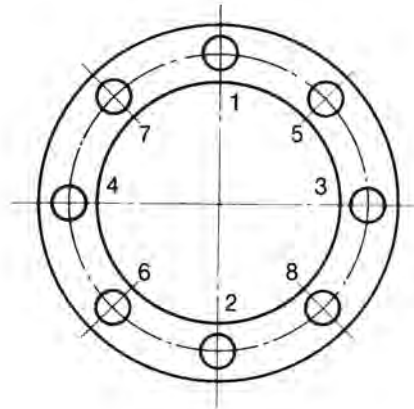

Removal

AS Power-Locks are not self-locking. The individual rings are tapered so that the inner and outer rings will spring apart after the last screw has been loosened.

1. Loosen the locking screws in several steps following a diametrically opposite sequence. Do not remove the screws completely.
2. Remove the hub and Power-Lock from the shaft.

Note: If the AS Power-Lock is still locked even after loosening the bolts, then insert bolts into the jack screw holes (see photo below) and screw them in until it unlocks.

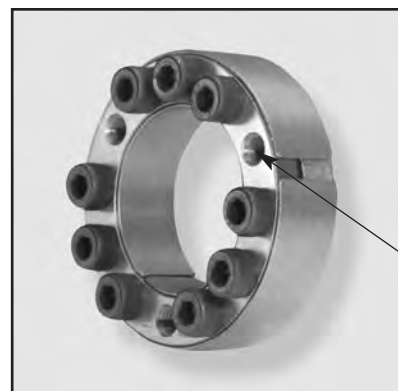

Jack Screw Holes for Removal

Design Examples

1. Hub mounting utilizing one Power-Lock.

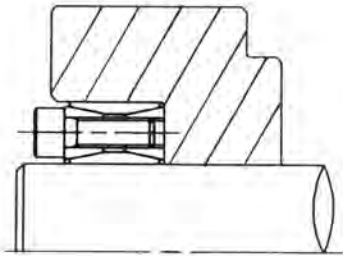

2. Hub mounting with Power-Lock located on opposite sides of hub:

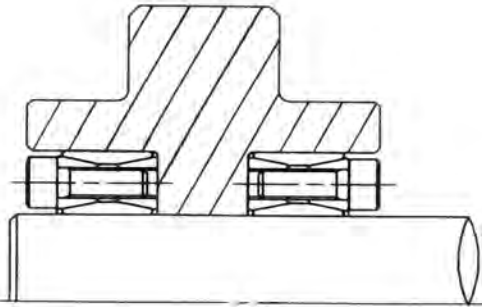

With this arrangement, twice the torque will be transmitted.

3. Rigid shaft coupling mounting with two Power-Locks:

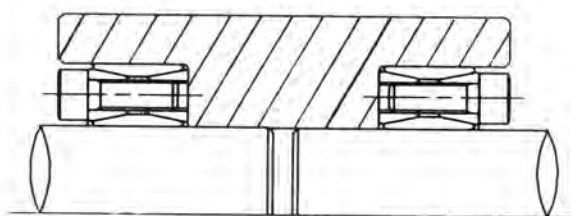
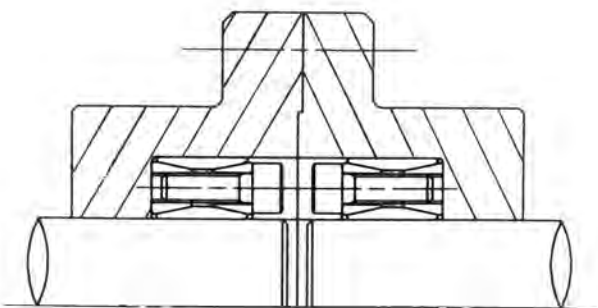

4. Hub mounting in the middle of a shaft:

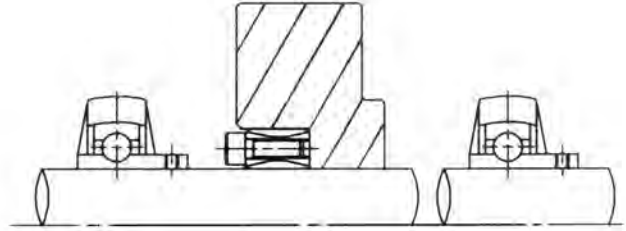

Power-Lock can be used at any place on the shaft without keyway.

5. Hub mounting utilizing two Power-Locks:

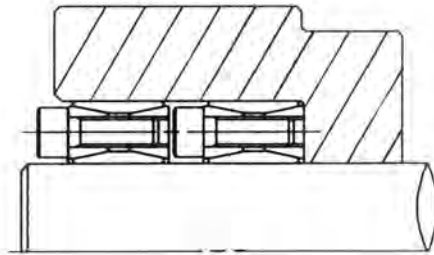

In this arrangement, Power-Lock transmits twice torque.

6. Hub mounted on a stepped shaft:

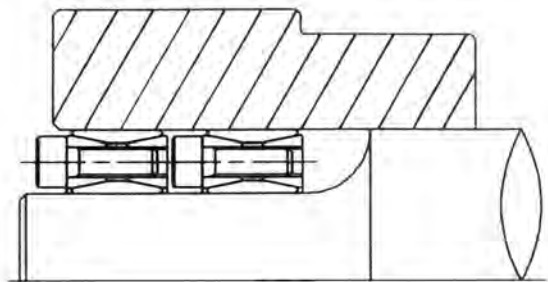

This arrangement is often used in conjunction with thin hub wall applications, for hubs with a straight through bore.

7. Lever or cam mounting:

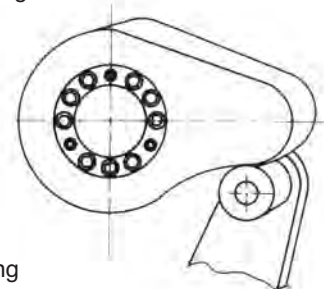

Positioning and adjusting are extremely easy.

Specification Table

d = inside diameter of Power-Lock and outside diameter of the shaft.
 T₁ = machining tolerances for shaft.
 D = outer diameter of Power-Lock and hub counter bore inside diameter.
 T₂ = machining tolerances for hub counter bore (D)
 ℓ, L, Lt = width dimensions after tightening of the screws.
 F = maximum transmissible axial force.
 M_t = maximum transmissible torque.
 pH = contact pressure between Power-Lock and hub bore.
 pS = contact pressure between Power-Lock and shaft.
 M_A = required tightening torque per locking screw.
 D_N = Minimum hub outside diameter for single Power-Lock installation (K₃=0.6) and is based on Y.P. 32,000 psi hub material.
For other hub materials, calculate the hub o.d. per the Selection Guide.

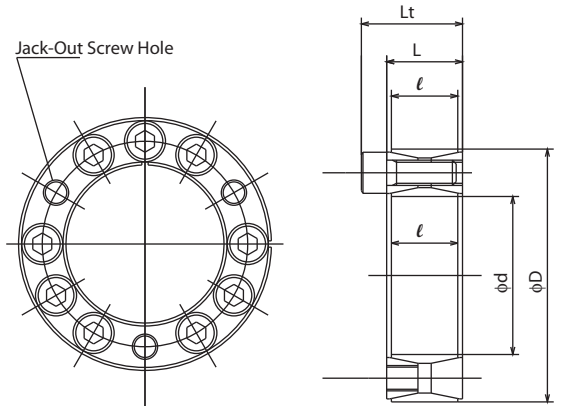

All dimensions in inches unless otherwise stated.

Model Number	Power Lock Dimensions							Max. F (lbf)	Max. M _t (ft-lb)	Pressures		Locking Screws			Minimum Hub Dia. D _N
	d	T ₁	D	T ₂	ℓ	L	Lt			pH (psi)	pS (psi)	Qty.	Size (mm)	M _A (ft-lb)	
PL 3/4	0.750	+0	1.850	-0	0.709	0.787	1.024	5,940	188	12,370	30,290	6	M6 x 18	12	2.345
PL 7/8	0.875		1.850		0.709	0.787	1.024	5,940	217	12,370	26,020	6	M6 x 18	12	2.345
PL1	1.000	-0.0013	1.969	+0.0013	0.709	0.787	1.024	7,480	318	14,650	29,010	8	M6 x 18	12	2.615
PL1 1/8	1.125		2.165		0.709	0.787	1.024	7,480	354	13,370	25,450	8	M6 x 18	12	2.790
PL1 3/16	1.188	+0	2.159	-0	0.709	0.819	1.055	7,480	376	13,370	24,320	8	M6 x 18	12	2.790
PL1 1/4	1.250		2.362		0.709	0.787	1.024	9,460	499	15,360	29,010	10	M6 x 18	12	3.180
PL1 3/8	1.375		2.365		0.709	0.773	1.009	9,460	550	15,360	26,310	10	M6 x 18	12	3.185
PL1 7/16	1.438		2.559		0.709	0.787	1.024	10,560	637	15,500	27,730	11	M6 x 18	12	3.455
PL1 1/2	1.500		2.559		0.709	0.787	1.024	10,560	658	15,500	26,590	11	M6 x 18	12	3.455
PL1 5/8	1.625		2.953		0.827	0.945	1.260	15,840	1,085	17,490	31,570	9	M8 x 22	30	4.155
PL1 11/16	1.688		2.953		0.827	0.945	1.260	15,840	1,122	17,490	30,480	9	M8 x 22	30	4.155
PL1 3/4	1.750		2.953		0.827	0.945	1.260	15,840	1,164	17,490	29,940	9	M8 x 22	30	4.155
PL1 7/8	1.875		3.150		0.827	0.945	1.260	15,840	1,244	16,350	27,440	9	M8 x 22	30	4.325
PL1 15/16	1.938		3.150		0.827	0.945	1.260	15,840	1,287	16,350	26,590	9	M8 x 22	30	4.325
PL2	2.000	+0	3.346	-0	0.827	0.945	1.260	19,360	1,627	18,910	31,570	11	M8 x 22	30	4.850
PL2 1/8	2.125		3.346		0.827	0.945	1.260	19,360	1,729	18,910	29,360	11	M8 x 22	30	4.850
PL2 3/16	2.188		3.543		0.827	0.945	1.260	19,360	1,779	17,780	28,870	11	M8 x 22	30	5.015
PL2 1/4	2.250		3.543		0.827	0.945	1.260	19,360	1,827	17,780	28,070	11	M8 x 22	30	5.015
PL2 3/8	2.375		3.531		0.827	1.008	1.323	19,360	1,931	17,780	26,590	11	M8 x 22	30	4.995
PL2 7/16	2.438		3.740		0.827	0.945	1.260	21,120	2,170	18,340	28,010	12	M8 x 22	30	5.355
PL2 1/2	2.500		3.740		0.827	0.945	1.260	21,120	2,228	18,340	27,300	12	M8 x 22	30	5.355
PL2 9/16	2.563		3.737		0.827	0.962	1.277	21,120	2,278	18,340	26,730	12	M8 x 22	30	5.350
PL2 5/8	2.625		4.337		0.984	1.073	1.467	31,020	3,400	19,340	31,940	11	M10 x 25	60	6.345
PL2 11/16	2.688		4.337		0.984	1.073	1.467	31,020	3,480	19,340	31,200	11	M10 x 25	60	6.345
PL2 3/4	2.750		4.337		0.984	1.073	1.467	31,020	3,537	19,340	30,430	11	M10 x 25	60	6.345
PL2 7/8	2.875		4.528		0.984	1.102	1.496	31,020	3,732	18,490	29,150	11	M10 x 25	60	6.505
PL2 15/16	2.938		4.528		0.984	1.102	1.496	31,020	3,812	18,490	28,580	11	M10 x 25	60	6.505
PL3	3.000		4.724		0.984	1.102	1.496	31,020	3,855	17,780	28,010	11	M10 x 25	60	6.685
PL3 3/8	3.375		+0		4.921	-0	0.984	1.102	1.496	33,660	4,745	18,630	27,160	12	M10 x 25
PL3 7/16	3.438	5.118		0.984	1.102		1.496	33,660	4,846	17,920	26,730	12	M10 x 25	60	7.260
PL3 1/2	3.500	5.118		0.984	1.102		1.496	33,660	4,933	17,920	26,160	12	M10 x 25	60	7.260
PL3 3/4	3.750	5.305		0.984	1.151		1.544	36,520	5,729	18,770	26,590	13	M10 x 25	60	7.665
PL3 15/16	3.938	5.708		1.142	1.302		1.774	45,100	7,378	18,490	26,730	11	M12 x 30	105	8.200
PL4	4.000	5.843		1.142	1.299		1.772	45,100	7,522	18,060	26,310	11	M12 x 30	105	8.315
PL4 7/16	4.438	6.496		1.142	1.299		1.772	49,280	9,114	17,780	25,880	12	M12 x 30	105	9.190
PL4 1/2	4.500	6.496		1.142	1.299		1.772	49,280	9,258	17,780	25,600	12	M12 x 30	105	9.190
PL4 15/16	4.938	7.087		1.339	1.496		1.969	61,600	12,730	17,350	24,890	15	M12 x 35	105	9.935
PL5	5.000	7.087		1.339	1.496		1.969	61,600	12,870	17,350	24,600	15	M12 x 35	105	9.935
PL5 1/2	5.500	7.492	1.339	1.438	1.910	65,560	15,120	17,490	23,750	16	M12 x 35	105	10.535		
PL6	6.000	8.268	1.399	1.496	1.969	77,880	19,530	18,770	25,580	19	M12 x 35	105	11.945		
PL6 1/2	6.500	8.858	1.575	1.732	2.283	90,200	24,450	17,210	23,460	16	M14 x 40	167	12.380		
PL7	7.000	9.252	1.575	1.732	2.283	95,700	27,990	17,490	23,180	17	M14 x 40	167	13.010		
PL7 1/2	7.500	+0	9.823	-0	1.890	2.144	2.695	112,640	35,220	16,210	21,330	20	M14 x 45	167	13.445
PL7 7/8	7.875		10.235		1.890	2.052	2.603	118,360	38,910	16,350	21,190	21	M14 x 45	167	14.050
PL8	8.000		10.504		1.890	2.047	2.598	118,360	39,560	15,930	20,900	21	M14 x 45	167	14.295
PL8 1/2	8.500		11.220		2.008	2.205	2.835	141,020	50,050	16,640	22,040	18	M16 x 50	257	15.436
PL9	9.000		11.669		2.008	2.205	2.835	141,020	53,020	15,930	20,760	18	M16 x 50	257	15.880
PL9 1/2	9.500		12.154		2.008	2.205	2.835	156,640	62,200	17,210	21,900	20	M16 x 50	257	16.985
PL10	10.000		12.795		2.008	2.205	2.835	180,180	75,220	18,770	23,890	23	M16 x 50	257	18.485
PL10 1/2	10.500		13.319		2.008	2.205	2.835	180,180	78,840	18,060	22,750	23	M16 x 50	257	18.950
PL11	11.000		14.000		2.402	2.482	3.191	207,240	95,480	16,500	20,900	22	M18 x 60	351	19.277
PL11 13/16	11.813		-0.0032		14.762	-0.0032	2.402	2.606	3.314	224,400	111,400	17,060	21,330	24	M18 x 60

Notes: All models from PL 3/4 to PL4 are also available in stainless steel. Inner ring and outer ring are Type 304 stainless steel. All other parts are Type 630 SS.

Specification Table

d = inside diameter of Power-Lock and outside diameter of the shaft.
 T₁ = machining tolerances for shaft.
 D = outer diameter of Power-Lock and hub counter bore inside diameter.
 T₂ = machining tolerances for hub counter bore (D)
 ℓ, L, Lt = width dimensions after tightening of the screws.
 F = maximum transmissible axial force.
 M_t = maximum transmissible torque.
 pH = contact pressure between Power-Lock and hub bore.
 pS = contact pressure between Power-Lock and shaft.
 M_A = required tightening torque per locking screw.
 D_N = Minimum hub outside diameter for single Power-Lock installation
 (K₃=0.6) and is based on Y.P. 32,000 psi hub material.
For other hub materials, calculate the hub o.d. per the Selection Guide.

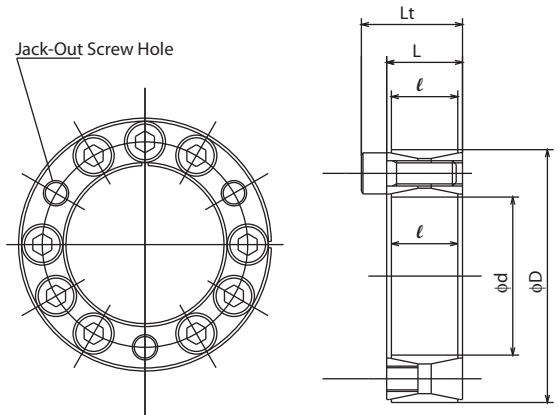

All dimensions in inches unless otherwise stated.

Model Number (d x D in mm)	Power Lock Dimensions							Max. F (lbf)	Max. M _t (ft-lb)	Pressures		Locking Screws			Minimum Hub Dia. D _N
	d	T ₁	D	T ₂	ℓ	L	Lt			pH (psi)	pS (psi)	Qty.	Size (mm)	M _A (ft-lb)	
PL019X47	0.748	+0 -0.0013	1.850	-0 +0.0013	0.709	0.787	1.024	5,960	181	12,330	30,470	6	M6 x 18	12	2.342
PL020X47	0.787		1.850		0.709	0.787	1.024	5,960	196	12,330	28,870	6	M6 x 18	12	2.342
PL022X47	0.866		1.850		0.709	0.787	1.024	5,960	217	12,330	26,260	6	M6 x 18	12	2.342
PL024X50	0.945		1.969		0.709	0.787	1.024	7,490	297	14,660	30,620	6	M6 x 18	12	2.610
PL025X50	0.984		1.969		0.709	0.787	1.024	7,490	311	14,660	29,460	8	M6 x 18	12	2.610
PL028X55	1.102		2.165		0.709	0.787	1.024	7,490	347	13,350	26,129	8	M6 x 18	12	2.796
PL030X55	1.181	2.165	0.630	0.787	1.024	7,490	376	13,350	24,520	8	M6 x 18	12	2.796		
PL032X60	1.260	+0 -0.0015	2.362	-0 +0.0015	0.709	0.787	1.024	9,470	499	15,380	28,730	10	M6 x 18	12	3.178
PL035X60	1.378		2.362		0.709	0.787	1.024	9,470	550	15,380	26,260	10	M6 x 18	12	3.178
PL038X65	1.496		2.559		0.709	0.787	1.024	10,570	658	15,530	26,550	11	M6 x 18	12	3.441
PL040X65	1.575		2.559		0.709	0.787	1.024	10,570	695	15,530	25,250	11	M6 x 18	12	3.441
PL042X75	1.654		2.953		0.827	0.945	1.260	15,880	1,100	17,560	31,050	9	M8 x 22	30	4.157
PL045X75	1.772		2.953		0.827	0.945	1.260	15,880	1,181	17,560	29,020	9	M8 x 22	30	4.157
PL048X80	1.890	3.150	0.827	0.945	1.260	15,880	1,225	16,400	27,290	9	M8 x 22	30	4.328		
PL050X80	1.969	3.150	0.827	0.945	1.260	15,880	1,306	16,400	26,120	9	M8 x 22	30	4.328		
PL055X85	2.165	+0 -0.0018	3.346	-0 +0.0018	0.827	0.945	1.260	19,390	1,764	18,860	29,170	11	M8 x 22	30	4.843
PL060X90	2.362		3.543		0.827	0.945	1.260	19,390	1,926	17,850	26,700	11	M8 x 22	30	5.019
PL065X95	2.559		3.740		0.827	0.945	1.260	21,170	2,280	18,280	26,700	12	M8 x 22	30	5.346
PL070X110	2.756		4.331		0.984	1.102	1.496	31,050	3,542	19,300	30,470	11	M10 x 25	60	6.327
PL075X115	2.953		4.528		0.984	1.102	1.496	31,050	3,830	18,430	28,440	11	M10 x 25	60	6.492
PL080X120	3.150		4.724		0.984	1.102	1.496	31,050	4,052	17,850	26,700	11	M10 x 25	60	6.692
PL085X125	3.346	+0 -0.0021	4.921	-0 +0.0021	0.984	1.102	1.496	33,750	4,701	18,570	27,420	12	M10 x 25	60	7.078
PL090X130	3.543		5.118		0.984	1.102	1.496	33,750	4,989	17,850	25,830	12	M10 x 25	60	7.249
PL095X135	3.740		5.315		0.984	1.102	1.496	36,670	5,712	18,720	26,560	13	M10 x 25	60	7.668
PL100X145	3.937		5.709		1.142	1.299	1.772	45,225	7,380	18,430	26,700	11	M12 x 30	105	8.186
PL110X155	4.331		6.102		1.142	1.299	1.772	45,225	8,192	17,410	24,380	11	M12 x 30	105	8.564
PL120X165	4.724		6.496		1.142	1.299	1.772	49,500	9,668	17,850	24,380	12	M12 x 30	105	9.201
PL130X180	5.118	+0 -0.0025	7.087	-0 +0.0025	1.339	1.496	1.969	61,650	13,140	17,410	24,090	15	M12 x 35	105	9.945
PL140X190	5.512		7.480		1.339	1.496	1.969	65,700	15,130	17,560	23,800	16	M12 x 35	105	10.530
PL150X200	5.906		7.874		1.339	1.496	1.969	74,020	18,230	18,720	24,960	18	M12 x 35	105	11.361
PL160X210	6.299		8.268		1.339	1.496	1.969	78,070	20,440	18,720	24,670	19	M12 x 35	105	11.929
PL170X225	6.693		8.858		1.575	1.732	2.284	90,450	25,170	17,270	22,780	16	M14 x 40	166	12.394
PL180X235	7.087		9.252		1.575	1.732	2.284	95,850	28,340	17,560	22,930	17	M14 x 40	166	13.024
PL190X250	7.480	+0 -0.0028	9.843	-0 +0.0028	1.890	2.047	2.589	112,950	35,130	16,250	21,330	20	M14 x 45	166	13.482
PL200X260	7.874		10.236		1.890	2.047	2.589	118,570	38,990	16,400	21,180	21	M14 x 45	166	14.065
PL220X285	8.661		11.220		2.008	2.205	2.835	141,300	51,000	16,690	21,620	18	M16 x 50	257	15.511
PL240X305	9.449		12.008		2.008	2.205	2.835	157,050	61,840	17,410	22,060	20	M16 x 50	257	16.851
PL260X325	10.236		12.795		2.008	2.205	2.835	180,670	76,750	18,720	23,360	23	M16 x 50	257	18.461
PL280X355	11.024		13.976		2.402	2.598	3.307	207,670	95,200	16,540	20,890	22	M18 x 60	351	19.260
PL300X375	11.811	-0.0032	14.764	+0.0032	2.402	2.598	3.307	225,000	111,400	17,120	21,330	24	M18 x 60	351	20.593

Notes: All models also available in stainless steel. Inner and outer ring are type 304 stainless steel. All other parts are type 630SS.

The AD Metric Series Power-Lock has the similar construction to the AS Metric Series Power-Lock. The major difference is that the AD Series has over two times greater transmissible torque than that of the AS Series. The AD Metric Series and the AS Metric Series have the same inside and outside diameter.

Selection Guide:

1. a) Determine the required maximum torque (MtC) to be transmitted:

$$\text{Torque } MtC = \frac{5252 \times \text{HP}}{\text{RPM}} \text{ (ft-lb)}$$

b) If combined torsional and axial loads are to be transmitted, calculate the resulting torque as follows:

$$M_{t \text{ res}} = \sqrt{MtC^2 + \left(\frac{F \times d}{24}\right)^2} \leq M_t$$

Where:

Mt res = resultant torque to be transmitted

MtC = actual or maximum torque to be transmitted (ft-lb). This value is calculated in step 1 a) above.

F = axial load/thrust to be transmitted (lbs)

d = shaft diameter (inches)

Mt = maximum transmissible torque (ft-lb) of the Power Lock as specified in the AD Power-Lock specification tables.

2. Select a Power-Lock for the shaft diameter (d) from the AD Power-Lock specification tables in this catalogue and verify that the corresponding maximum transmissible torque (Mt) meets the torque requirement that was calculated in step 1. a) above. If torque is the primary requirement, select the necessary torque (Mt) from the same specification tables and determine the corresponding shaft diameter (d).

Note: Required peak torque should never exceed specified transmissible torque (Mt).

To increase transmissible torque (Mt):

Install 2 or 3 Power-Locks in series, increasing transmissible torque as follows:

- with 2 Power-Locks: $M_{trans.} = 2 \times Mt$

- with 3 Power-Locks: $M_{trans.} = 3 \times Mt$

The hub must be long enough to accommodate the assemblies.

3. Determine the recommended minimum hub outside diameter (DN) for the Power-Lock selected from the specification tables (which show the DN for material with a yield point of 32,000 p.s.i.) For other yield point materials, calculate the hub outside diameter (DN) by using the following equation:

$$D_N \geq D \times \sqrt{\frac{YP + (K_3 \times pH)}{YP - (K_3 \times pH)}} \text{ (inches or mm)}$$

Where

D = Outer diameter of the Power-Lock and hub counter bore inside diameter (inches or mm).

YP = yield point of hub material (p.s.i. or MPa).

pH = Contact pressure between the Power-Lock and hub bore.

See specification tables (p.s.i. or MPa).

K3 = Form factor depending on hub design-see Fig. 1, Fig. 2 or Fig. 3

Note: Use either all imperial values (inches/p.s.i.) or all metric values (mm/MPa) when calculating the value of DN.

4. Verify that the hub length (B) is adequate for the selected Power-Lock.

5. Check the applicable machining tolerance for the shaft and hub bore in the specification tables. A surface finish of 125 micro-inches for shafts and bores is generally adequate.

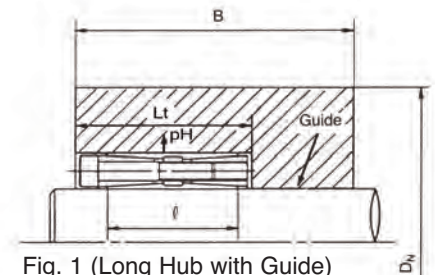

Fig. 1 (Long Hub with Guide)
where $B \geq 2\ell$
 $K_3=0.6$

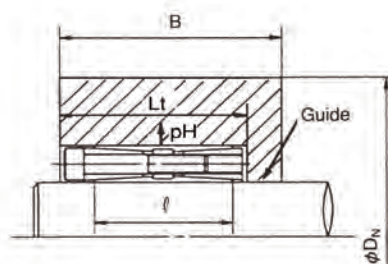

Fig. 2 (Short Hub with Guide)
where $Lt < B < 2\ell$
 $K_3=1.0$

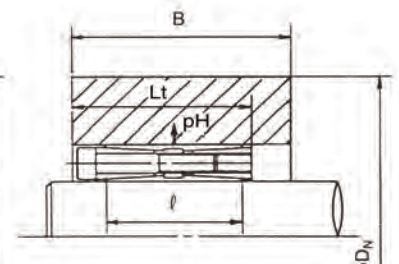

Fig. 3 (Short Hub without Guide)
 $K_3=1.0$

Installation

1. Verify that all contact surfaces, including the screw threads and screw head bearing surfaces, are clean and lightly oiled.

Note: Do NOT use Molybdenum Disulfide, "Molykote" or any other similar lubricants.

2. Slide the Power-Lock onto the shaft and into the hub bore, aligning them as required.

3. Tighten the locking screws gradually in the sequence illustrated in Figure 1 below. The tightening sequence is as follows:

- Hand-tighten 3 or 4 equally spaced locking screws until they make contact. Align and adjust the connection.
- Hand-tighten and take up all remaining locking screws.
- Use a torque wrench to tighten the screws further to approximately one-quarter the specified torque (M_A - as found in the AD Power-Lock specification tables).
- Increase the tightening torque to 1/2 of M_A .
- Finally, use the torque wrench to tighten the screws to the full tightening torque (M_A).
- Verify that the screws are completely tight by applying the specified tightening torque (M_A).

Notes:

- Even tightening is best accomplished by turning each screw in increments of approximately 90°.

Fig. 1: Tightening Sequence For Locking Screws.
(This is only an example - other number of locking screws is possible)

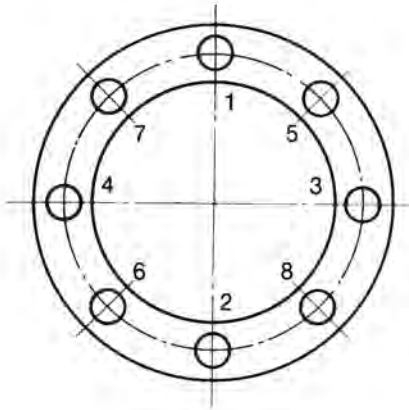

Removal

AD Power-Locks are not self-locking. The individual rings are tapered so that the inner and outer rings will spring apart after the last screw has been loosened.

- Loosen the locking screws in several steps following a diametrically opposite sequence. Do not remove the screws completely.
- Remove the hub and Power-Lock from the shaft.

Note:

- If the AD Power-Lock is still locked even after loosening the bolts, then insert bolts into the jack screw holes (see photo below) and screw them in until it unlocks.



Jack Screw Holes for Removal

Specification Table

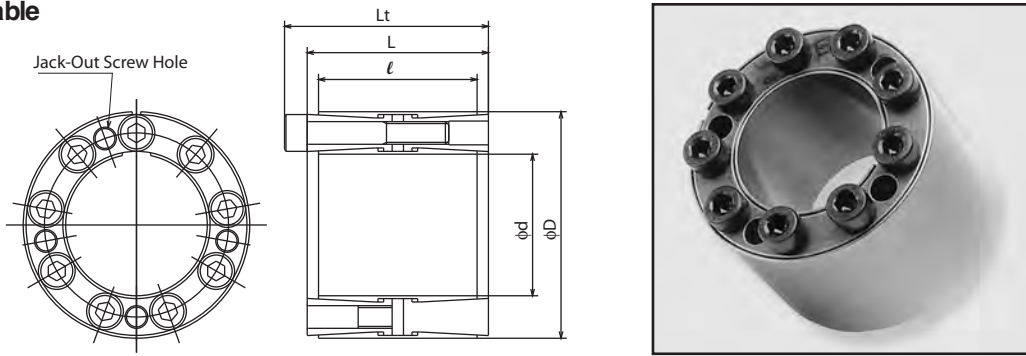

d = inside diameter of Power-Lock and outside diameter of the shaft.
 T₁ = machining tolerances for shaft.
 D = outer diameter of Power-Lock and hub counter bore inside diameter.
 T₂ = machining tolerances for hub counter bore (D)
 ℓ, L, Lt = width dimensions after tightening of the screws.
 F = maximum transmissible axial force.
 M_t = maximum transmissible torque.
 pH = contact pressure between Power-Lock and hub bore.
 pS = contact pressure between Power-Lock and shaft.
 M_A = required tightening torque per locking screw.
 D_N = Min. hub o.d. for single Power-Lock installation (form factor K₃=0.6) and is based on Yield Point 32,000 psi hub material. **For other hub materials, calculate the hub o.d. per the Selection Guide.**

All dimensions in inches unless otherwise stated.

Model Number (d x D in mm)	Power Lock Dimensions							Max. F (lbf)	Max. M _t (ft-lb)	Pressures		Locking Screws			Minimum Hub Dia. D _N
	d	T ₁	D	T ₂	ℓ	L	Lt			pH (psi)	pS (psi)	Qty.	Size (mm)	M _A (ft-lb)	
PL019X47AD	0.748	-0.0013	1.850	+0.0013	1.181	1.378	1.610	9,110	190	13,930	34,370	6	M6 x 28	12	2.418
PL020X47AD	0.787		1.850		1.181	1.378	1.610	9,110	200	13,930	32,630	6	M6 x 28	12	2.418
PL022X47AD	0.866		1.850		1.181	1.378	1.610	9,110	220	13,930	29,590	6	M6 x 28	12	2.418
PL024X50AD	0.945		1.969		1.378	1.575	1.810	12,170	320	14,940	31,040	8	M6 x 30	12	2.625
PL025X50AD	0.984		1.969		1.378	1.575	1.810	12,170	335	14,940	29,730	8	M6 x 30	12	2.625
PL028X55AD	1.102		2.165		1.378	1.575	1.810	12,170	375	13,490	26,540	8	M6 x 30	12	2.804
PL030X55AD	1.181	2.165	1.378	1.575	1.810	12,170	390	13,490	24,800	8	M6 x 30	12	2.804		
PL032X60AD	1.260	-0.0015	2.362	+0.0015	1.772	1.969	2.200	18,260	630	14,650	27,400	10	M6 x 35	12	3.110
PL035X60AD	1.378		2.362		1.772	1.969	2.200	18,260	680	14,650	24,950	10	M6 x 35	12	3.110
PL038X65AD	1.496		2.559		2.047	2.244	2.480	20,020	825	12,760	21,900	11	M6 x 40	12	3.268
PL040X65AD	1.575		2.559		2.047	2.244	2.480	20,020	875	12,760	20,880	11	M6 x 40	12	3.268
PL042X75AD	1.654		2.953		2.205	2.520	2.835	38,180	1,750	12,760	27,850	9	M8 x 50	30	3.997
PL045X75AD	1.772		2.953		2.205	2.520	2.835	38,180	2,820	15,670	25,970	9	M8 x 50	30	3.997
PL048X80AD	1.890	-0.0018	3.150	+0.0018	2.205	2.520	2.835	38,180	3,005	14,660	24,380	9	M8 x 50	30	4.173
PL050X80AD	1.969		3.150		2.205	2.520	2.835	38,180	3,105	14,660	23,510	9	M8 x 50	30	4.173
PL055X85AD	2.165		3.346		2.205	2.520	2.835	38,180	3,400	13,780	21,330	9	M8 x 50	30	4.370
PL060X90AD	2.362		3.543		2.205	2.520	2.835	46,790	4,550	15,960	23,940	11	M8 x 50	30	4.825
PL065X95AD	2.559		3.740		2.205	2.520	2.835	46,790	4,990	12,910	18,860	11	M8 x 50	30	4.787
PL070X110AD	2.756		4.331		2.756	3.071	3.465	74,390	8,560	16,540	25,970	11	M10 x 70	60	5.968
PL075X115AD	2.953	4.528	2.756	3.071	3.465	74,390	9,075	15,820	24,320	11	M10 x 70	60	6.147		
PL080X120AD	3.150	4.724	2.756	3.071	3.465	74,390	10,630	16,540	24,810	12	M10 x 70	60	6.510		
PL085X125AD	3.346	-0.0021	4.921	+0.0021	2.756	3.071	3.465	81,010	11,290	15,820	23,360	12	M10 x 70	60	6.682
PL090X130AD	3.543		5.118		2.756	3.071	3.465	81,010	12,920	16,540	23,940	13	M10 x 70	60	7.053
PL095X135AD	3.740		5.315		2.756	3.071	3.465	87,850	13,650	15,960	22,640	13	M10 x 70	60	7.237
PL100X145AD	3.937		5.709		3.543	3.937	4.409	119,600	19,560	15,670	22,780	12	M12 x 90	105	7.226
PL110X155AD	4.331		6.102		3.543	3.937	4.409	129,800	23,390	15,960	22,490	13	M12 x 90	105	8.301
PL120X165AD	4.724		6.496		3.543	3.937	4.409	149,700	29,450	17,270	23,800	15	M12 x 90	105	9.090
PL130X180AD	5.118	-0.0025	7.087	+0.0025	4.095	4.567	5.118	175,500	37,420	16,110	22,200	13	M14 x 90	105	9.680
PL140X190AD	5.512		7.480		4.095	4.567	5.118	202,600	46,420	17,560	23,800	15	M14 x 90	105	10.530
PL150X200AD	5.906		7.874		4.095	4.567	5.118	216,100	53,060	17,850	23,800	16	M14 x 90	105	11.150
PL160X210AD	6.299		8.268		4.095	4.567	5.118	229,600	60,150	17,850	23,650	17	M14 x 90	105	11.710
PL170X225AD	6.693		8.858		5.276	5.748	6.378	280,400	78,230	15,960	21,180	15	M16 x 120	166	12.008
PL180X235AD	7.087		9.252		5.276	5.748	6.378	300,200	88,560	16,400	21,330	16	M16 x 120	166	12.713
PL190X250AD	7.480	-0.0028	9.843	+0.0028	5.276	5.748	6.378	317,900	98,890	16,400	21,470	17	M16 x 120	166	13.524
PL200X260AD	7.874		10.236		5.276	5.748	6.378	317,900	104,100	15,670	20,310	17	M16 x 120	166	13.860
PL220X285AD	8.661		11.220		5.276	5.748	6.378	375,300	135,100	17,120	21,770	20	M16 x 120	257	15.650
PL240X305AD	9.449		12.008		5.276	5.748	6.378	412,800	162,400	17,410	21,910	22	M16 x 120	257	16.851
PL260X325AD	10.236		12.795		5.276	5.748	6.378	412,800	175,600	13,200	16,540	22	M16 x 120	257	16.474
PL280X355AD	11.024		13.976		6.496	6.969	7.756	585,000	268,600	17,120	21,770	20	M20 x 150	351	19.495
PL300X375AD	11.811	14.764	6.496	6.969	7.756	644,600	316,600	17,850	22,530	22	M20 x 150	351	20.911		

Section F

KE Power-Locks are self-centering and are ideal for A type sprockets and narrow gears. It is designed with a slit construction and special taper angle to cover a wide tolerance of shaft sizes, such as motor shafts. Available in a variety of sizes, including fractional inch sizes for smaller motors.

Construction

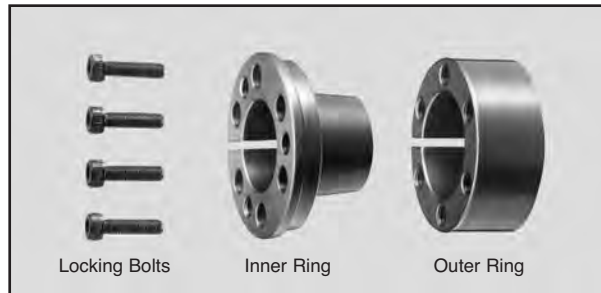
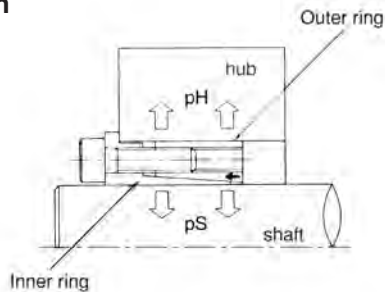

Selection Guide:

1. a) Determine the required maximum torque (MtC) to be transmitted:

$$\text{Torque } MtC = \frac{5252 \times \text{HP}}{\text{RPM}} \quad (\text{ft-lb})$$

b) If combined torsional and axial loads are to be transmitted, calculate the resulting torque as follows:

$$Mt \text{ res} = \sqrt{MtC^2 + \left(\frac{F \times d}{24}\right)^2} \leq Mt$$

$Mt \text{ res}$ = resultant torque to be transmitted

MtC = actual or maximum torque to be transmitted (ft-lb). This value is calculated in step 1 a) above.

F = axial load/thrust to be transmitted (lbs)

d = shaft diameter (inches)

Mt = maximum transmissible torque (ft-lb) of the Power-Lock as specified in the specification tables in this catalogue.

2. Select a Power-Lock for the shaft diameter (d) from the KE specification tables in this catalogue and verify that the corresponding maximum transmissible torque (Mt) meets the torque requirement that was calculated in step 1. a) above. If torque is the primary requirement, select the necessary torque (Mt) from the same specification tables and determine the corresponding shaft diameter (d). Note: Required peak torque should never exceed specified transmissible torque (Mt).

To increase transmissible torque (Mt):

Install 2 Power-Locks in series, increasing transmissible torque as follows:

- with 2 Power-Locks: $M_{\text{trans}} = 2 \times Mt$

The hub must be long enough to accommodate the assemblies.

3. Determine the recommended minimum hub outside diameter (DN) for the Power-Lock selected from the specification tables (which show the DN for material with a yield point of 32,000 p.s.i.) For other yield point materials, calculate the hub outside diameter (DN) by using the following equation:

$$DN \geq D \times \sqrt{\frac{YP + (K_3 \times pH)}{YP - (K_3 \times pH)}} \quad (\text{inches or mm}) \quad \text{Note: Use either all imperial values (inches/p.s.i.) or all metric values (mm/MPa) when calculating the value of } DN.$$

Where

D = Outer diameter of the Power-Lock and hub counter bore inside diameter (inches or mm).

YP = yield point of hub material (p.s.i. or MPa)

pH = Contact pressure between the Power-Lock and hub bore. See KE Power-Lock Specification Tables (p.s.i. or MPa).

K_3 = Form factor depending on hub design (see Fig.1, Fig.2, or Fig.3).

4. Verify that the hub length (B) is adequate for the selected Power-Lock.

5. Determine the applicable machine tolerance from the KE Power-Lock Specification Table.

Fig. 1
(Long hub with guide)
where $B \geq 2l_1$
 $K_3=0.8$

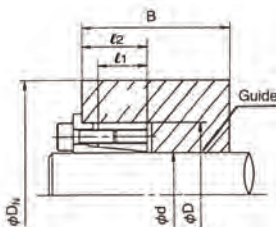

Fig. 2
(Short Hub with Guide)
where $l_2 < B < 2l_1$
 $K_3=1.0$

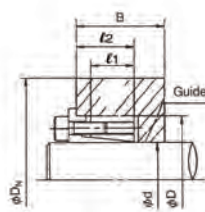
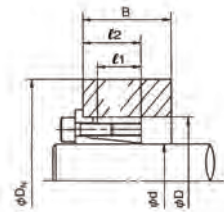

Fig. 3
(Short Hub without Guide)
 $K_3=1.0$



Installation

1. Verify that all contact surfaces, including the screw threads and screw head bearing surfaces, are clean and lightly oiled.

Note: Do NOT use Molybdenum Disulfide, "Molykote" or any other similar lubricants.

2. Slide the Power-Lock onto the shaft and into the hub bore, aligning them as required.

3. Tighten the locking screws gradually in the sequence illustrated in Figure 1 below. The tightening sequence is as follows:

- a) Hand-tighten 3 or 4 equally spaced locking screws until they make contact. Align and adjust the connection.
- b) Hand-tighten and take up all remaining locking screws.
- c) Use a torque wrench to tighten the screws further to approximately one-quarter the specified torque (M_A - as found in the KE Power-Lock specification tables).
- d) Increase the tightening torque to 1/2 of M_A .
- e) Finally, use the torque wrench to tighten the screws to the full tightening torque (M_A).
- f) Verify that the screws are completely tight by applying the specified tightening torque (M_A).

Notes:

- i) Even tightening is best accomplished by turning each screw in increments of approximately 90°.

Fig. 1: Tightening Sequence For Locking Screws.
(This is only an example - other number of locking screws is possible)

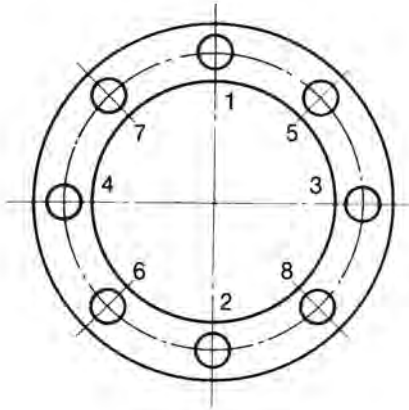

Removal

KE Power-Locks are not self-locking. The individual rings are tapered so that the inner and outer rings will spring apart after the last screw has been loosened.

1. Loosen the locking screws in several steps following a diametrically opposite sequence. Do not remove the screws completely.
2. Remove the hub and Power-Lock from the shaft.

Note:

- If the KE Power-Lock is still locked even after loosening the bolts, then insert bolts into the jack screw holes (see photo below) and screw them in until it unlocks.



Jack Screw Holes for Removal

Specification Table

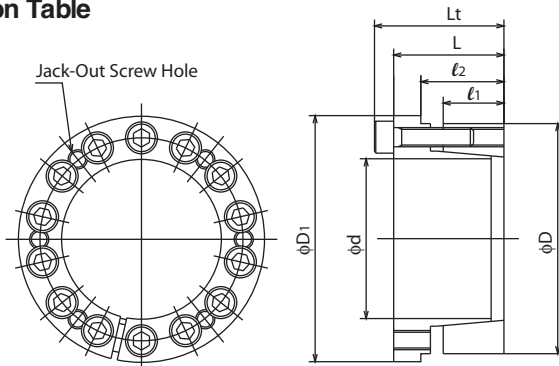

d = inside diameter of Power-Lock and outside diameter of the shaft.
 T₁ = machining tolerances for shaft.
 T_w = special wider machining tolerances for shaft. Transmissible axial force and transmissible torque will be 90% of the ratings shown in the specification table below.
 D₁ = outer diameter of Power-Lock.
 D = hub counter bore inside diameter
 T₂ = machining tolerances for hub counter bore (D)
 ℓ₁, ℓ₂, L, Lt = width dimensions after tightening of the screws.
 F = maximum transmissible axial force.
 Mt = maximum transmissible torque.
 p_H = contact pressure between Power-Lock and hub bore.
 p_S = contact pressure between Power-Lock and shaft.
 M_A = required tightening torque per locking screw.
 D_N = Minimum hub outside diameter for single Power-Lock installation (form factor K₃=0.8) and is based on Y.P. 32,000 psi hub material.
For other hub materials, calculate the hub o.d. per the Selection Guide.

All dimensions in inches unless otherwise stated.

Model Number	Power Lock Dimensions										Max. F (lbf)	Max. Mt (ft-lb)	Pressures		Locking Screws			Minimum Hub Dia. D _N
	d	T ₁	T _w	D ₁	D	T ₂	ℓ ₁	ℓ ₂	L	Lt			p _H (psi)	p _S (psi)	Qty.	Size (mm)	M _A (ft-lb)	
PL 3/8KE	0.375	+0.0006 -0.0009	+0.0007 -0.0023	1.063	0.938	-0 +0.0013	0.394	0.563	0.650	0.807	1,340	20	11,300	28,260	3	M4 x 12	4	1.254
PL 1/2KE	0.500	+0.0007 -0.0011	+0.0007 -0.0028	1.188	1.063	-0 ~ +0.0013	0.394	0.563	0.650	0.807	1,780	40	13,330	28,260	4	M4 x 12	4	1.503
PL 5/8KE	0.625	+0.0007 -0.0011	+0.0007 -0.0028	1.313	1.188	-0 ~ +0.0015	0.472	0.688	0.807	0.965	2,680	74	14,930	28,260	6	M4 x 16	4	1.758
PL 3/4KE	0.750	+0.0007 -0.0011	+0.0010 -0.0011	1.438	1.313	-0	0.472	0.688	0.807	0.965	2,680	90	13,480	23,620	6	M4 x 16	4	1.864
PL 7/8KE	0.875	+0.0007 -0.0011	+0.0010 -0.0011	1.750	1.563	-0	0.591	0.813	0.984	1.181	4,380	170	14,780	26,380	6	M5 x 20	7	2.303
PL1 KE	1.000	+0.0007 -0.0011	+0.0010 -0.0011	1.875	1.688	+0.0015	0.591	0.813	0.984	1.181	5,830	260	18,260	30,870	8	M5 x 20	7	2.763
PL1 1/8KE	1.125	+0.0007 -0.0011	+0.0010 -0.0011	2.000	1.875	+0.0015	0.669	0.938	1.102	1.299	6,560	325	16,380	27,250	9	M5 x 20	7	2.897
PL1 3/16KE	1.188	+0.0010 -0.0015	+0.0010 -0.0039	2.063	1.938	-0 ~ +0.0015	0.669	0.938	1.102	1.299	7,290	380	17,540	28,550	10	M5 x 20	7	3.101
PL1 1/4KE	1.250	+0.0010 -0.0015	+0.0010 -0.0039	2.125	2.000	-0	0.669	0.938	1.102	1.299	7,290	400	16,960	27,250	10	M5 x 20	7	3.144
PL1 3/8KE	1.375	+0.0010 -0.0015	+0.0010 -0.0039	2.250	2.125	-0	0.669	0.938	1.102	1.299	7,290	445	15,940	24,780	10	M5 x 20	7	3.240
PL1 7/16KE	1.438	+0.0010 -0.0015	+0.0010 -0.0039	2.500	2.313	-0	0.748	1.063	1.260	1.496	8,230	525	14,780	28,910	8	M6 x 25	12	3.409
PL1 1/2KE	1.500	+0.0012 -0.0018	+0.0012 -0.0047	2.563	2.375	-0	0.748	1.063	1.260	1.496	10,290	680	18,120	28,550	10	M6 x 25	12	3.870
PL1 5/8KE	1.625	+0.0012 -0.0018	+0.0012 -0.0047	2.688	2.500	+0.0018	0.748	1.063	1.260	1.496	10,290	740	17,100	26,380	10	M6 x 25	12	3.948
PL1 11/16KE	1.688	+0.0012 -0.0018	+0.0012 -0.0047	2.750	2.563	-0	0.748	1.063	1.260	1.496	10,290	765	16,810	25,360	10	M6 x 25	12	4.011
PL1 3/4KE	1.750	+0.0012 -0.0018	+0.0012 -0.0047	2.813	2.625	-0	0.748	1.063	1.260	1.496	10,290	795	16,380	24,490	10	M6 x 25	12	4.055
PL1 7/8KE	1.875	+0.0012 -0.0018	+0.0012 -0.0047	2.938	2.750	+0.0021	0.748	1.063	1.260	1.496	12,350	1,020	18,700	27,390	12	M6 x 25	12	4.565
PL1 15/16KE	1.938	+0.0012 -0.0018	+0.0012 -0.0047	3.000	2.813	-0	0.748	1.063	1.260	1.496	13,380	1,145	19,860	28,840	13	M6 x 25	12	4.848
PL2 KE	2.000	+0.0012 -0.0018	+0.0012 -0.0047	3.063	2.875	-0	0.748	1.125	1.358	1.594	13,380	1,180	19,420	27,830	13	M6 x 25	12	4.885
PL2 1/8KE	2.125	+0.0014 -0.0021	+0.0014 -0.0055	3.188	3.000	+0.0018	0.748	1.125	1.358	1.594	14,400	1,350	20,000	28,260	14	M6 x 25	12	5.196
PL2 3/16KE	2.188	+0.0014 -0.0021	+0.0014 -0.0055	3.250	3.063	-0	0.748	1.125	1.358	1.594	14,400	1,390	19,565	27,390	14	M6 x 25	12	5.229
PL2 1/4KE	2.250	+0.0014 -0.0021	+0.0014 -0.0055	3.313	3.125	-0	0.748	1.125	1.358	1.594	14,400	1,430	19,275	26,670	14	M6 x 25	12	5.285
PL2 3/8KE	2.375	+0.0014 -0.0021	+0.0014 -0.0055	3.438	3.250	+0.0021	0.748	1.125	1.358	1.594	15,440	1,620	19,855	27,100	15	M6 x 25	12	5.602
PL2 7/16KE	2.438	+0.0014 -0.0021	+0.0014 -0.0055	3.500	3.313	-0	0.748	1.125	1.358	1.594	15,440	1,660	19,420	26,380	15	M6 x 25	12	5.629
PL2 1/2KE	2.500	+0.0014 -0.0021	+0.0014 -0.0055	3.563	3.375	-0	0.748	1.125	1.358	1.594	15,440	1,700	19,130	25,800	15	M6 x 25	12	5.681
PL2 5/8KE	2.625	+0.0014 -0.0021	+0.0014 -0.0055	3.688	3.500	+0.0025	0.748	1.125	1.358	1.594	15,440	1,790	18,400	24,490	15	M6 x 25	12	5.756
PL2 11/16KE	2.688	+0.0014 -0.0021	+0.0014 -0.0055	3.938	3.750	-0	0.866	1.250	1.594	1.909	22,810	2,710	22,320	30,580	12	M8 x 30	30	7.040
PL2 3/4KE	2.750	+0.0014 -0.0021	+0.0014 -0.0055	4.000	3.813	-0	0.866	1.250	1.594	1.909	22,810	2,770	21,590	29,860	12	M8 x 30	30	6.974
PL2 7/8KE	2.875	+0.0014 -0.0021	+0.0014 -0.0055	4.125	3.938	-0	0.866	1.250	1.594	1.909	22,810	2,900	20,870	28,550	12	M8 x 30	30	7.024
PL2 15/16KE	2.938	+0.0014 -0.0021	+0.0014 -0.0055	4.188	4.000	-0	0.866	1.250	1.594	1.909	22,810	2,960	20,580	27,970	12	M8 x 30	30	7.065
PL3 KE	3.000	+0.0014 -0.0021	+0.0014 -0.0055	4.188	4.063	+0.0021	0.866	1.250	1.594	1.909	22,810	3,020	20,290	27,390	12	M8 x 30	30	7.105
PL3 3/8KE	3.375	+0.0014 -0.0021	+0.0014 -0.0055	4.625	4.438	-0	0.866	1.313	1.634	1.949	26,620	3,970	21,590	28,400	14	M8 x 30	30	8.118
PL3 7/16KE	3.438	+0.0014 -0.0021	+0.0014 -0.0055	4.688	4.500	+0.0021	0.866	1.313	1.634	1.949	26,620	4,040	21,300	27,830	14	M8 x 30	30	8.149
PL3 1/2KE	3.500	+0.0014 -0.0021	+0.0014 -0.0055	5.000	4.750	-0	1.142	1.688	2.126	2.520	42,270	6,530	24,350	33,040	14	M10 x 40	60	9.631
PL3 3/4KE	3.750	+0.0014 -0.0021	+0.0014 -0.0055	5.250	5.063	-0	1.142	1.688	2.126	2.520	42,270	7,000	22,750	30,730	14	M10 x 40	60	9.657
PL3 5/16KE	3.938	+0.0014 -0.0021	+0.0014 -0.0055	5.500	5.250	+0.0025	1.142	1.688	2.126	2.520	42,270	7,350	22,030	28,730	14	M10 x 40	60	9.754
PL4 KE	4.000	+0.0014 -0.0021	+0.0014 -0.0055	5.500	5.313	-0	1.142	1.688	2.126	2.520	42,270	7,470	21,740	28,840	14	M10 x 40	60	9.768

The AE Metric Series Power-Lock features a single taper design with a self-locking taper to provide good self-centering action and concentricity. The AE Metric Series Power-Lock is used wherever self-centering action and good concentricity of mounted components is essential and where hubs with straight-thru bores are used. The AE Metric Series Power-Lock has the same inside diameter and outside diameter as the AS Metric Series Power-Lock; and so they are interchangeable with each other in many applications..

Construction

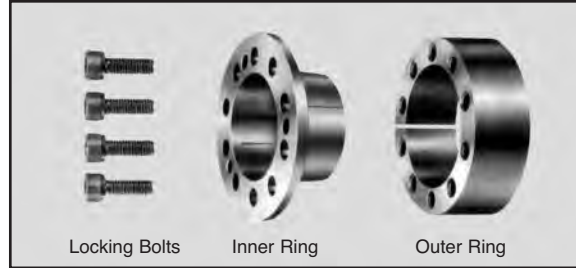
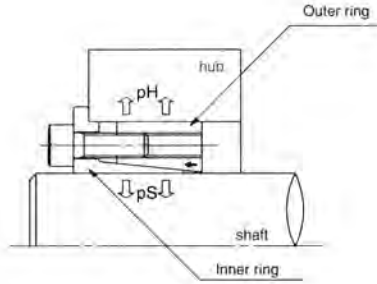

Selection Guide:

1. a) Determine the required maximum torque (MtC) to be transmitted:

$$\text{Torque } MtC = \frac{5252 \times \text{HP}}{\text{RPM}} \quad (\text{ft-lb})$$

b) If combined torsional and axial loads are to be transmitted, calculate the resulting torque as follows:

$$Mt_{\text{res}} = \sqrt{MtC^2 + \left(\frac{F \times d}{24}\right)^2} \leq Mt$$

Mt res = resultant torque to be transmitted

MtC = actual or maximum torque to be transmitted (ft-lb). This value is calculated in step 1 a) above.

F = axial load/thrust to be transmitted (lbs)

d = shaft diameter (inches)

Mt = maximum transmissible torque (ft-lb) of the Power-Lock as specified in the specification tables in this catalogue.

2. Select a Power-Lock for the shaft diameter (d) from the AE specification tables in this catalogue and verify that the corresponding maximum transmissible torque (Mt) meets the torque requirement as calculated in step 1. a) above. If torque is the primary requirement, select the necessary torque (Mt) from the same specification tables and determine the corresponding shaft diameter (d). Note: Required peak torque should never exceed specified transmissible torque (Mt).

To increase transmissible torque (Mt):

Install 2 or 3 Power-Locks in series, increasing transmissible torque as follows:

- with 2 Power-Locks: Mtrans. = 2 x Mt

- with 3 Power-Locks: Mtrans. = 3 x Mt

The hub must be long enough to accommodate the assemblies.

3. Determine the recommended minimum hub outside diameter (DN) for the Power-Lock selected from the specification tables (which show the DN for material with a yield point of 32,000 p.s.i.) For other yield point materials, calculate the hub outside diameter (DN) by using the following equation:

$$DN \geq D \times \sqrt{\frac{YP + (K_3 \times pH)}{YP - (K_3 \times pH)}} \quad (\text{inches or mm}) \quad \text{Note: Use either all imperial values (inches/p.s.i.) or all metric values (mm/MPa) when calculating the value of DN.}$$

Where

D = Outer diameter of the Power-Lock and hub counter bore inside diameter (inches or mm).

YP = yield point of hub material (p.s.i. or MPa).

pH = Contact pressure between the Power-Lock and hub bore. See AE Power-Lock Specification Tables (p.s.i. or MPa).

K3 = Form factor depending on hub design (see Fig.1, Fig.2, or Fig.3).

4. Determine the applicable machine tolerance from the AE Power-Lock Specification Table.

Fig. 1
(Long hub with guide)
where $B \geq 2\ell_1$
 $K_3=0.8$

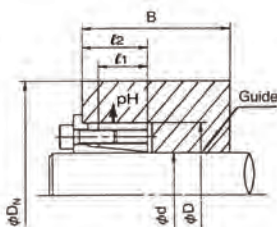

Fig. 2
(Short Hub with Guide)
where $\ell_2 < B < 2\ell_1$
 $K_3=1.0$

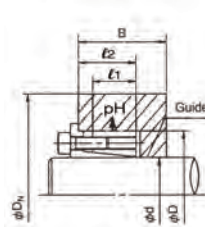
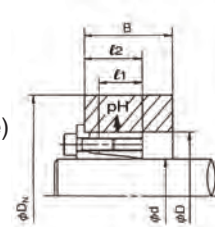

Fig. 3
(Short Hub without Guide)
 $K_3=1.0$



Installation

1. Verify that all contact surfaces, including the screw threads and screw head bearing surfaces, are clean and lightly oiled.

Note: Do NOT use Molybdenum Disulfide, "Molykote" or any other similar lubricants.

2. Slide the Power-Lock onto the shaft and into the hub bore, aligning them as required.

3. Tighten the locking screws gradually in the sequence illustrated in Figure 1 below. The tightening sequence is as follows:

- a) Hand-tighten 3 or 4 equally spaced locking screws until they make contact. Align and adjust the connection.
- b) Hand-tighten and take up all remaining locking screws.
- c) Use a torque wrench to tighten the screws further to approximately one-quarter the specified torque (M_A - as found in the AE Power-Lock specification tables).
- d) Increase the tightening torque to 1/2 of M_A .
- e) Finally, use the torque wrench to tighten the screws to the full tightening torque (M_A).
- f) Verify that the screws are completely tight by applying the specified tightening torque (M_A).

Notes:

- i) Even tightening is best accomplished by turning each screw in increments of approximately 90°.

Fig. 1: Tightening Sequence For Locking Screws.
(This is only an example - other number of locking screws is possible)

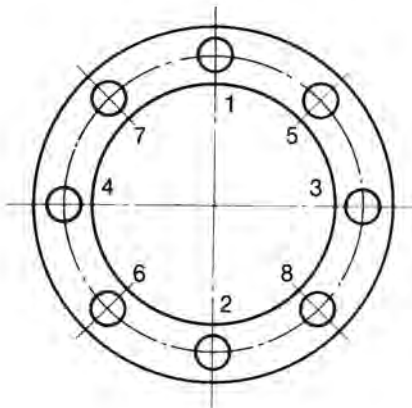

Removal

AE Power-Locks are not self-locking. The individual rings are tapered so that the inner and outer rings will spring apart after the last screw has been loosened.

1. Loosen the locking screws in several steps following a diametrically opposite sequence. Do not remove the screws completely.
2. Remove the hub and Power-Lock from the shaft.

Note:

- If the AE Power-Lock is still locked even after loosening the bolts, then insert bolts into the jack screw holes (see photo below) and screw them in until it unlocks.



Jack Screw Holes for Removal

Specification Table

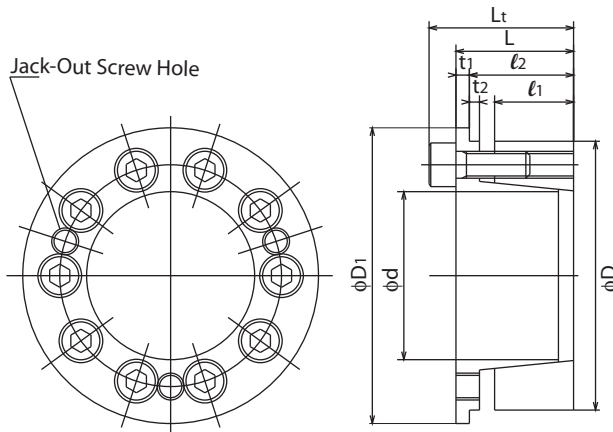

d = inside diameter of Power-Lock and outside diameter of the shaft.
 T_1 = machining tolerances for shaft.
 D = outer diameter of Power-Lock and hub counter bore inside diameter.
 T_2 = machining tolerances for hub counter bore (D)
 $\ell_1, \ell_2, L, L_t, t_1, t_2$ width dimensions after tightening of the screws.
 F = maximum transmissible axial force.
 M_t = maximum transmissible torque.
 p_H = contact pressure between Power-Lock and hub bore.
 p_S = contact pressure between Power-Lock and shaft.
 M_A = required tightening torque per locking screw.
 D_N = Minimum hub outside diameter for single Power-Lock installation (form factor $K_3=0.8$) and is based on Y.P. 32,000 psi hub material.
For other hub materials, calculate the hub o.d. per the Selection Guide.

All dimensions in inches unless otherwise stated.

Model Number (d x D in mm)	Power Lock Dimensions												Max. F (lbf)	Max. M_t (ft-lb)	Pressures		Locking Screws			Min. Hub Dia. D_N
	d	T_1	D_1	D	T_2	ℓ_1	ℓ_2	L	L_t	t_1	t_2	pH (psi)			pS (psi)	Qty.	Size (mm)	M_A (ft-lb)		
PL019X47AE	0.748		2.087	1.850		0.748	0.976	1.075	1.311	0.098	0.079	6,320	195	13,490	41,640	6	M6 x 18	12	2.628	
PL020X47AE	0.787		2.087	1.850		0.748	0.976	1.075	1.311	0.098	0.079	6,320	200	13,490	39,470	6	M6 x 18	12	2.628	
PL022X47AE	0.866	+0	2.087	1.850	-0	0.748	0.976	1.075	1.311	0.098	0.079	6,320	225	13,490	35,980	6	M6 x 18	12	2.628	
PL024X50AE	0.945	-0.0013	2.244	1.969	+0.0013	0.748	0.996	1.095	1.331	0.098	0.079	7,380	290	14,800	39,760	7	M6 x 18	12	2.903	
PL025X50AE	0.984		2.244	1.969		0.748	0.996	1.095	1.331	0.098	0.079	7,380	305	14,800	40,920	7	M6 x 18	12	2.903	
PL028X55AE	1.102		2.441	2.165		0.748	0.996	1.126	1.362	0.130	0.079	8,440	380	15,380	39,030	8	M6 x 18	12	3.248	
PL030X55AE	1.181		2.441	2.165		0.748	0.996	1.126	1.362	0.130	0.079	8,440	415	15,380	36,420	8	M6 x 18	12	3.248	
PL032X60AE	1.260		2.638	2.362		0.807	1.075	1.217	1.453	0.142	0.098	10,570	550	16,400	38,740	10	M6 x 18	12	3.652	
PL035X60AE	1.378		2.638	2.362		0.807	1.075	1.217	1.453	0.142	0.098	10,570	605	16,400	35,400	10	M6 x 18	12	3.652	
PL038X65AE	1.496		2.874	2.559		0.807	1.083	1.224	1.461	0.142	0.098	10,570	660	15,090	33,080	10	M6 x 18	12	3.806	
PL040X65AE	1.575	+0	2.874	2.559	-0	0.807	1.083	1.224	1.461	0.142	0.098	10,570	690	15,090	31,490	10	M6 x 18	12	3.806	
PL042X75AE	1.654	-0.0015	3.268	2.953	+0.0015	0.807	1.213	1.370	1.685	0.158	0.118	17,590	1,210	18,860	41,350	9	M8 x 22	30	4.927	
PL045X75AE	1.772		3.268	2.953		0.807	1.213	1.370	1.685	0.158	0.118	17,590	1,290	18,860	38,600	9	M8 x 22	30	4.927	
PL048X80AE	1.890		3.465	3.150		0.807	1.221	1.378	1.693	0.158	0.118	19,550	1,520	19,730	40,630	10	M8 x 22	30	5.407	
PL050X80AE	1.969		3.465	3.150		0.807	1.221	1.378	1.629	0.158	0.118	19,550	1,595	19,730	39,130	10	M8 x 22	30	5.407	
PL055X85AE	2.165		3.701	3.346		0.925	1.213	1.370	1.693	0.158	0.118	19,550	1,735	18,570	35,110	10	M8 x 22	30	5.532	
PL060X90AE	2.362		3.898	3.543		0.925	1.213	1.370	1.685	0.158	0.118	19,550	1,880	17,700	31,780	10	M8 x 22	30	5.700	
PL065X95AE	2.559	+0	4.095	3.740	-0	0.925	1.213	1.370	1.685	0.158	0.118	23,390	2,460	19,880	35,690	12	M8 x 22	30	6.452	
PL070X110AE	2.756	-0.0018	4.724	4.331	+0.0018	1.102	1.437	1.614	1.685	0.177	0.158	30,900	3,540	19,150	35,840	10	M10 x 25	60	7.294	
PL075X115AE	2.953		4.921	4.528		1.102	1.437	1.614	2.008	0.177	0.158	30,900	3,760	18,280	33,370	10	M10 x 25	60	7.416	
PL080X120AE	3.150		5.118	4.724		1.102	1.437	1.614	2.008	0.177	0.158	37,080	4,850	21,040	37,080	12	M10 x 25	60	8.477	
PL085X125AE	3.346		5.315	4.921		1.102	1.437	1.614	2.008	0.177	0.158	37,080	5,140	20,170	35,400	12	M10 x 25	60	8.572	
PL090X130AE	3.543		5.118	5.118		1.102	1.476	1.693	2.087	0.217	0.158	37,080	5,500	19,440	34,970	12	M10 x 25	60	8.702	
PL095X135AE	3.740	+0	5.709	5.315	-0	1.102	1.476	1.693	2.087	0.217	0.158	43,480	6,725	21,910	38,740	14	M10 x 25	60	9.832	
PL100X145AE	3.937	-0.0021	6.102	5.709	+0.0021	1.339	1.732	1.969	2.362	0.236	0.158	46,570	7,600	17,850	31,595	15	M10 x 25	105	9.226	
PL110X155AE	4.331		6.575	6.102		1.339	1.732	1.969	2.362	0.236	0.158	46,570	8,410	16,830	28,730	15	M10 x 25	105	9.557	
PL120X165AE	4.724		6.969	6.496		1.339	1.732	1.969	2.362	0.236	0.158	55,840	11,000	18,680	31,595	15	M10 x 25	105	10.777	
PL130X180AE	5.118		7.677	7.087		1.496	1.987	2.244	0.756	0.276	0.236	67,770	14,460	18,720	31,050	15	M12 x 35	105	11.772	
PL140X190AE	5.512	+0	8.071	7.480	-0	1.496	1.987	2.244	0.756	0.276	0.236	67,770	15,570	17,850	28,730	15	M12 x 35	105	12.089	
PL150X200AE	5.906	-0.0025	8.465	7.874	+0.0025	1.496	1.987	2.284	0.315	0.315	0.236	81,230	19,930	20,310	32,070	18	M12 x 35	105	13.781	

EL Power-Locks are a frictional keyless locking device for connecting hubs and shafts that are subject to large torque variations. The EL Power-Lock is a simple structure consisting of two tapered rings. They are ideal for fastening gears, pulleys, sprockets, cams, etc. to metric sized shafts from 10mm to 150mm. They are perfect for applications requiring timing and backlash-free connections. When locking force (F) is applied to the EL Power-Lock, it pushes the inner and outer rings together, generating radial direction pressures (pH and pS) on the shaft and to the hub bore. These pressures (pH and pS) create the friction fit connection.

Construction

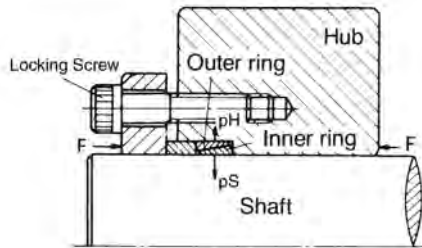

Selection Guide

EL Series Power-Locks must be used with metric shaft sizes.

1. a) Determine the required maximum torque (MtC) to be transmitted:

$$\text{Torque MtC} = \frac{5252 \times \text{HP}}{\text{RPM}} \quad (\text{ft-lb})$$

b) If combined torsional and axial loads are to be transmitted, calculate the resulting torque as follows:

$$M_{t \text{ res}} = \sqrt{M_{tC}^2 + \left(\frac{F \times d}{24}\right)^2} \leq M_t$$

Where:

Mt res = resultant torque to be transmitted

MtC = actual or maximum torque to be transmitted (ft-lb).

This value is calculated in step 1 a) above.

F = axial load/thrust to be transmitted (lbs)

d = shaft diameter (inches)

Mt = maximum transmissible torque (ft-lb) of the Power-Lock as specified in the specification tables in this catalogue.

2. Select an EL Series Power-Lock for the shaft diameter (d) from the specification tables and verify that the corresponding maximum transmissible torque (Mt) meets the torque requirements.

Note: Required peak torque should never exceed specified transmissible torque (Mt). Catalogue values for (Mt) are based on a contact pressure of 14,220 p.s.i. between the shaft and the EL Series Power-Lock in a lightly oiled installation. Higher torque capacities can be obtained by using 2 or more EL Series Power-Locks in series.

3. Determine the required locking force (PA) from the EL Power-Lock Specification Tables.

For EL Series Power-Lock, in addition to (PA), a preload (PO) is required to bridge the clearance for the specified fit. The required total locking force for solid EL Series Power-Locks is: $P_A' = P_O + P_A$

(see the EL Power-Lock specification tables).

The locking force is normally obtained by using multiple locking screws and a clamp ring or flange.

4. Determine the number, size and grade of screws to be used based on the required locking force and individual screw clamp load (see Table 1).

$$\text{Clamp load/ locking screw} = \frac{\text{required locking force (P}_A') \text{ or P}_A}{\text{number of locking screws}}$$

Table 1: Clamp Load

Bolt Size	CLAMP LOAD TABLE					
	S.A.E. Grade 2		S.A.E. Grade 5		S.A.E. Grade 8	
	Load* (lbs)	Torque (lb-in)	Load* (lbs)	Torque (lb-in)	Load* (lbs)	Torque (lb-in)
4 - 40	250	5	380	8	540	12
4 - 48	275	6	420	9	600	13
6 - 32	375	10	580	16	820	23
6 - 40	420	12	640	18	920	25
8 - 32	580	19	900	30	1 260	41
8 - 36	610	20	940	31	1 320	43
10 - 24	725	27	1 120	43	1 580	60
10 - 32	825	31	1 285	49	1 800	68
	(lbs)	(lb-ft)	(lbs)	(lb-ft)	(lbs)	(lb-ft)
1/4 - 20	1 300	5	2 000	8	2 850	12
1/4 - 28	1 500	6	2 300	10	3 250	14
5/16 - 18	2 150	11	3 350	17	4 700	24
5/16 - 24	2 400	13	3 700	19	5 200	27
3/8 - 16	3 200	20	4 950	30	6 950	45
3/8 - 24	3 600	22	5 600	35	7 900	50
7/16 - 14	4 400	30	6 800	50	9 600	70
7/16 - 20	4 900	35	7 550	55	10 700	80
1/2 - 13	5 850	50	9 050	75	12 800	105
1/2 - 20	6 550	55	10 200	85	14 400	120
9/16 - 12	7 550	70	11 600	110	16 400	115
9/16 - 18	8 350	80	13 000	120	18 300	170

* Clamp load (lbs) is equal to 75% of bolt proof load.

Selection Guide (Continued)

5. Determine the size of clamp ring or flange based on the bolt circle diameter and the thickness of the clamp ring or flange.
- c) Recommended clearance “x” and maximum values for R are shown in the EL Power-Lock Specification Tables.
6. Determine the hub outside diameter (D_N) using the EL Power-Lock Selection Tables shown in this section.

Clamp Plate Mounting and Removal

There are two basic methods for mounting the clamp plate:

1. Hub bolting permits axial positioning of the hub as well as angular adjustment.
2. Shaft bolting requires the hub to be backed against a shoulder to support the clamping force.

EL Series Power-Lock Installation

Since the torque is transmitted by contact pressure and friction between the frictional surfaces, the condition of the contact surfaces and the proper tightening of the locking screws are important.

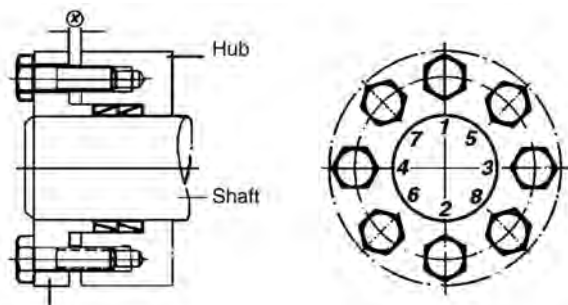

Fig.1 Tightening sequence example

1. Carefully clean and lightly oil the shaft, hub bore, spacer sleeves and EL Series Power-Locks.

Note: Do NOT use a Molybdenum Disulphide LUBRICANT (“MOLYKOTE” OR THE LIKE).

2. Install the parts in the following order:

- a) Hub (the play between hub bore and shaft affects the true running of the hub).
- b) Spacer sleeve to bridge the undercut (if needed)
- c) Outer ring/inner ring (both parts must slide on easily). For one EL Series Power-Lock install the outer ring first. Otherwise, install the inner ring first.
- d) Spacer sleeve and clamp flange or clamp ring (both parts should slide on easily).
- e) Carefully oil the locking screw threads and head bearing surfaces.

Note: Do NOT use Molybdenum Disulphide.

3. Tighten the locking screws evenly and in several steps following the diametrically opposite sequence illustrated in Fig. 1

- a) Tighten the screws by hand until a slight positive contact is established. Make final alignment adjustments to the connection.
- b) Tighten the screws to approx. one-half the specified torque using an extended key or torque wrench.

- c) Tighten the screws to full tightening torque using a torque wrench.

- d) Verify that the screws are fully tightened by applying the specified torque.

4. Check the clearance (x) between the clamp flange and the hub. The clamp ring should not make contact with the face of the hub. The gap between the clamp ring and hub face should be even all the way around.

EL Series Power-Lock Removal

Note: EL Series Power-Locks are not self-locking.

1. Remove any accumulated contaminants from the connection.
2. Loosen the locking screws in several stages following a diametrically opposite sequence.
3. Remove the hub and EL Series Power-Locks from the shaft. If the EL Series Power-Lock is jammed, loosen it by tapping it with a light hammer.

Specification Table

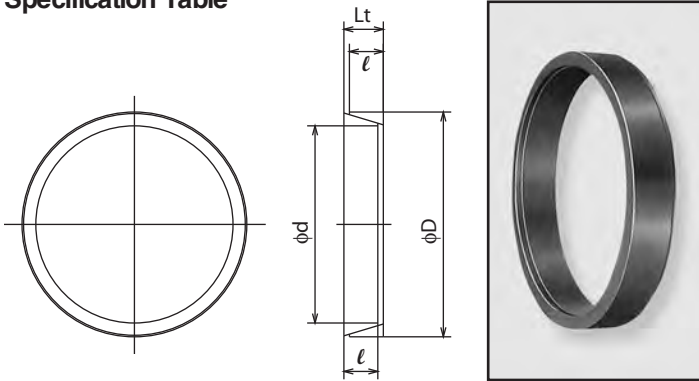

d = inside diameter of Power-Lock and outside diameter of the shaft.
 T₁ = machining tolerances for shaft.
 D = outer diameter of Power-Lock and hub counter bore inside diameter.
 T₂ = machining tolerances for hub counter bore (D)
 ℓ, Lt = width dimensions after tightening of the screws.
 P₀ = initial pressure required for contact with shaft and hub bore.
 P_A = actual locking pressure to generate pS = 14,290 p.s.i.
 F = maximum transmissible axial force.
 M_t = maximum transmissible torque of one EL Power-Lock.
 pH = contact pressure between Power-Lock and hub bore.
 pS = contact pressure between Power-Lock and shaft.

All dimensions in inches unless otherwise stated.

Model Number (d x D in mm)	EL Power Lock Dimensions						P ₀ (lbf)	P _A (lbf)	Max. F (lbf)	Max. M _t (ft-lb)	Pressures			
	d	T ₁	D	T ₂	ℓ	Lt					pH (psi)	pS (psi)		
PL010X013E	0.394	+0 -0.00043	0.512	-0 +0.00071	0.146	0.177	1,320	1,390	310	5	10,950	14,290		
PL012X015E	0.472		0.591		0.146	0.177	1,120	1,650	365	7	11,380	14,290		
PL013X016E	0.512		0.630		0.146	0.177	1,060	1,800	400	9	11,520	14,290		
PL014X018E	0.551		0.709		0.209	0.248	1,830	2,770	615	14	11,090	14,290		
PL015X019E	0.591		0.748		0.209	0.248	2,310	2,970	660	16	11,240	14,290		
PL016X020E	0.630		0.787		0.209	0.248	2,200	3,170	705	19	11,380	14,290		
PL017X021E	0.669		0.827		0.209	0.248	2,070	3,370	750	21	11,520	14,290		
PL018X022E	0.709		0.866		0.209	0.248	2,000	3,560	790	23	11,660	14,290		
PL019X024E	0.748	+0 -0.00051	0.945	-0 +0.00083	0.209	0.248	2,770	3,760	835	26	11,240	14,290		
PL020X025E	0.787		0.984		0.209	0.248	2,660	3,960	880	29	11,380	14,290		
PL022X026E	0.866		1.024		0.209	0.248	2,000	4,360	970	35	12,090	14,290		
PL024X028E	0.945		1.102		0.209	0.248	1,850	4,750	1,060	42	12,230	14,290		
PL025X030E	0.984		1.181		0.209	0.248	2,180	4,850	1,100	45	11,810	14,290		
PL028X032E	1.102		1.260		0.209	0.248	1,610	5,544	1,230	56	12,510	14,290		
PL030X035E	1.181		1.378		0.209	0.248	1,870	5,940	1,320	65	12,230	14,290		
PL032X036E	1.260		1.417		0.209	0.248	1,740	6,340	1,410	74	12,660	14,290		
PL035X040E	1.378	+0 -0.00063	1.575	-0 +0.00098	0.236	0.275	2,220	7,830	1,740	101	12,520	14,290		
PL036X042E	1.417		1.654		0.236	0.275	2,550	8,050	1,780	105	12,230	14,290		
PL038X044E	1.496		1.732		0.236	0.275	2,440	8,510	1,890	118	12,230	14,290		
PL040X045E	1.575		1.772		0.260	0.315	3,040	9,900	2,190	144	12,660	14,290		
PL042X048E	1.654		1.890		0.260	0.315	3,430	10,340	2,310	159	12,520	14,290		
PL045X052E	1.772		2.047		0.339	0.393	5,740	14,520	3,210	237	12,380	14,290		
PL048X055E	1.890		2.165		0.339	0.393	5,410	15,400	3,430	270	12,380	14,290		
PL050X057E	1.969		2.244		0.339	0.393	5,210	16,060	3,565	292	12,520	14,290		
PL055X062E	2.165	+0 -0.0018	2.441	-0 +0.0018	0.339	0.393	4,770	17,600	3,915	355	12,660	14,290		
PL056X064E	2.205		2.520		0.409	0.472	6,420	21,780	4,840	445	12,520	14,290		
PL060X068E	2.362		2.677		0.409	0.472	6,030	23,320	5,170	510	12,520	14,290		
PL063X071E	2.480		2.795		0.409	0.472	5,740	24,420	5,435	565	12,660	14,290		
PL065X073E	2.559		2.874		0.409	0.472	5,590	25,300	5,610	600	12,660	14,290		
PL070X079E	2.756		3.110		0.480	0.551	6,820	31,900	7,085	815	12,660	14,290		
PL071X080E	2.795		3.150		0.480	0.551	6,730	32,340	7,195	840	12,660	14,290		
PL075X084E	2.953		3.307		0.480	0.551	7,570	34,100	7,590	933	12,660	14,290		
PL080X091E	3.150	3.583	0.591	0.669	10,580	44,880	9,900	1,310	12,520	14,290				
PL085X096E	3.346	+0 -0.0021	3.780	-0 +0.0021	0.591	0.669	10,010	47,520	10,560	1,475	12,520	14,290		
PL090X101E	3.543		3.976		0.591	0.669	9,480	50,380	11,220	1,655	12,660	14,290		
PL095X106E	3.740		4.173		0.591	0.669	9,000	53,240	11,880	1,845	12,800	14,290		
PL100X114E	3.937		4.488		0.736	0.826	13,420	69,740	15,620	2,545	12,520	14,290		
PL110X124E	4.331		4.882		0.736	0.826	14,390	76,780	17,160	3,075	12,660	14,290		
PL120X134E	4.724		5.276		0.736	0.826	13,240	83,820	18,700	3,650	12,800	14,290		
PL130X148E	5.118		+0		5.827	-0	0.984	1.102	21,050	122,760	27,280	5,785	12,520	14,290
PL140X158E	5.512		-0.0025		6.220	+0.0025	0.984	1.102	19,650	132,220	29,370	6,725	12,660	14,290
PL150X168E	5.906		6.614		0.984	1.102	18,410	141,630	31,460	7,740	12,660	14,290		

Specification Table

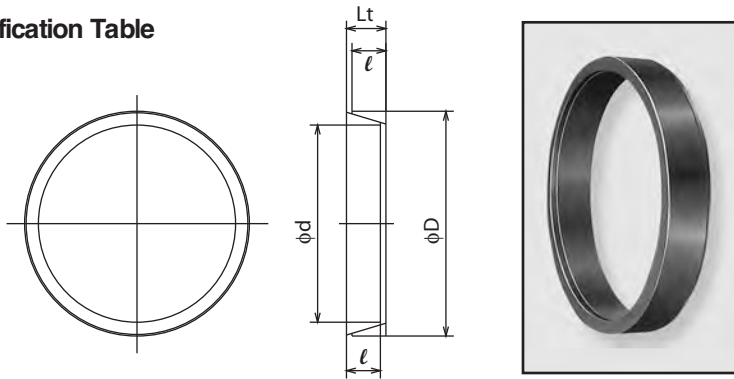

X = Recommended clearance between clamp flange and hub.
 d₁ = spacer sleeve inside diameter.
 D₁ = spacer sleeve outside diameter.
 R = radius in hub outer bore.
 D_N = Minimum hub outside diameter for single Power Lock installation (form factor K₃ = 0.6) and is based on Y.P. 32,000 psi hub material. **For other hub materials, calculate the hub o.d. per the Selection Tables on next page.**

All dimensions in inches unless otherwise stated.

Model Number	Clearance (X)			Spacer Sleeve		Max. Radius R	Minimum Hub Dia. D _N
	1 Power Lock	2 Power Locks	3 Power Locks	d ₁	D ₁		
PL010X013E	0.08	0.08	0.12	0.398	0.508	0.004	1.378
PL012X015E	0.08	0.08	0.12	0.476	0.586	0.004	1.457
PL013X016E	0.12	0.12	0.16	0.516	0.626	0.004	1.496
PL014X018E	0.12	0.12	0.16	0.555	0.705	0.004	1.575
PL015X019E	0.12	0.12	0.16	0.595	0.744	0.004	1.614
PL016X020E	0.12	0.12	0.16	0.634	0.784	0.004	1.654
PL017X021E	0.12	0.12	0.16	0.673	0.823	0.004	1.693
PL018X022E	0.12	0.12	0.16	0.713	0.862	0.004	1.732
PL019X024E	0.12	0.12	0.16	0.756	0.937	0.004	1.811
PL020X025E	0.12	0.12	0.16	0.795	0.976	0.004	1.850
PL022X026E	0.12	0.12	0.16	0.874	1.106	0.004	1.890
PL024X028E	0.12	0.12	0.16	0.953	1.095	0.004	1.969
PL025X030E	0.12	0.12	0.16	0.992	1.173	0.004	2.047
PL028X032E	0.12	0.12	0.16	1.110	1.250	0.004	2.126
PL030X035E	0.12	0.12	0.16	1.181	1.370	0.004	2.244
PL032X036E	0.12	0.12	0.16	1.268	1.409	0.004	2.323
PL035X040E	0.12	0.12	0.16	1.386	1.567	0.004	2.598
PL036X042E	0.12	0.12	0.16	1.425	1.646	0.004	2.677
PL038X044E	0.12	0.12	0.16	1.504	1.724	0.004	2.756
PL040X045E	0.12	0.16	0.20	1.583	1.764	0.004	3.031
PL042X048E	0.12	0.16	0.20	1.661	1.882	0.004	3.071
PL045X052E	0.12	0.16	0.20	1.780	2.039	0.004	3.150
PL048X055E	0.12	0.16	0.20	1.898	2.158	0.004	3.307
PL050X057E	0.12	0.16	0.20	1.976	2.236	0.008	3.386
PL055X062E	0.12	0.16	0.20	2.173	2.433	0.008	3.976
PL056X064E	0.12	0.16	0.20	2.213	2.512	0.008	3.898
PL060X068E	0.12	0.16	0.20	2.480	2.669	0.008	4.055
PL063X071E	0.12	0.16	0.20	2.488	2.787	0.008	4.843
PL065X073E	0.12	0.16	0.20	2.567	2.866	0.008	4.882
PL070X079E	0.12	0.20	0.24	2.768	3.098	0.118	5.236
PL071X080E	0.12	0.20	0.24	2.087	3.138	0.118	5.276
PL075X084E	0.12	0.20	0.24	2.965	3.295	0.118	5.315
PL080X091E	0.16	0.20	0.24	3.161	3.571	0.118	5.669
PL085X096E	0.16	0.20	0.24	3.358	3.768	0.118	5.906
PL090X101E	0.16	0.20	0.24	3.555	3.965	0.118	6.772
PL095X106E	0.16	0.20	0.24	3.752	4.161	0.118	6.969
PL100X114E	0.16	0.24	0.28	3.949	4.476	0.016	6.969
PL110X124E	0.16	0.24	0.28	4.343	4.870	0.016	8.110
PL120X134E	0.16	0.24	0.28	4.736	5.264	0.016	8.465
PL130X148E	0.20	0.28	0.35	5.134	5.811	0.016	8.898
PL140X158E	0.20	0.28	0.35	5.527	6.204	0.016	9.291
PL150X168E	0.20	0.28	0.35	5.921	6.598	0.016	10.472

Selection Table

Minimum Hub Diameter DN (inches)
Form Factor K3=0.6

Model Number	Yield Point of Various Hub Materials (p.s.i.)									
	21,000	25,000	30,000	32,000	35,000	40,000	43,000	50,000	57,000	64,000
PL010X013E	-	1.378	1.378	1.378	1.378	1.378	1.378	1.378	1.378	1.378
PL012X015E	-	1.457	1.457	1.457	1.457	1.457	1.457	1.457	1.457	1.457
PL013X016E	-	1.496	1.496	1.496	1.496	1.496	1.496	1.496	1.496	1.496
PL014X018E	1.575	1.575	1.575	1.575	1.575	1.575	1.575	1.575	1.575	1.575
PL015X019E	-	1.614	1.614	1.614	1.614	1.614	1.614	1.614	1.614	1.614
PL016X020E	-	1.654	1.654	1.654	1.654	1.654	1.654	1.654	1.654	1.654
PL017X021E	-	1.693	1.693	1.693	1.693	1.693	1.693	1.693	1.693	1.693
PL018X022E	-	1.732	1.732	1.732	1.732	1.732	1.732	1.732	1.732	1.732
PL019X024E	1.811	1.811	1.811	1.811	1.811	1.811	1.811	1.811	1.811	1.811
PL020X025E	1.850	1.850	1.850	1.850	1.850	1.850	1.850	1.850	1.850	1.850
PL022X026E	2.008	1.890	1.890	1.890	1.890	1.890	1.890	1.890	1.890	1.890
PL024X028E	2.126	1.969	1.969	1.969	1.969	1.969	1.969	1.969	1.969	1.969
PL025X030E	2.087	2.047	2.047	2.047	2.047	2.047	2.047	2.047	2.047	2.047
PL028X032E	2.244	2.126	2.126	2.126	2.126	2.126	2.126	2.126	2.126	2.126
PL030X035E	-	2.520	2.323	2.244	2.244	2.244	2.244	2.244	2.244	2.244
PL032X036E	-	2.559	2.362	2.323	2.323	2.323	2.323	2.323	2.323	2.323
PL035X040E	3.228	2.835	2.638	2.598	2.598	2.598	2.598	2.598	2.598	2.598
PL036X042E	3.189	2.835	2.677	2.677	2.677	2.677	2.677	2.677	2.677	2.677
PL038X044E	3.228	2.913	2.756	2.756	2.756	2.756	2.756	2.756	2.756	2.756
PL040X045E	-	3.504	3.150	3.031	2.913	2.874	2.874	2.874	2.874	2.874
PL042X048E	-	3.504	3.228	3.071	3.071	2.992	2.992	2.992	2.992	2.992
PL045X052E	3.898	3.504	3.268	3.150	3.150	3.110	3.150	3.150	3.150	3.150
PL048X055E	4.016	3.622	3.386	3.307	3.307	3.307	3.307	3.307	3.307	3.307
PL050X057E	4.094	3.701	3.504	3.386	3.346	3.346	3.346	3.346	3.346	3.346
PL055X062E	-	4.528	4.134	3.976	3.819	3.661	3.583	3.543	3.543	3.543
PL056X064E	4.764	4.331	4.016	3.898	3.780	3.780	3.780	3.780	3.780	3.780
PL060X068E	4.921	4.488	4.173	4.055	3.937	3.937	3.937	3.937	3.937	3.937
PL063X071E	-	5.630	5.079	4.843	4.646	4.409	4.291	4.094	4.055	4.055
PL065X073E	-	5.669	5.118	4.882	4.685	4.488	4.370	4.173	4.134	4.134
PL070X079E	-	6.063	5.472	5.236	5.039	4.803	4.685	4.449	4.370	4.370
PL071X080E	-	6.102	5.512	5.276	5.079	4.843	4.724	4.528	4.449	4.449
PL075X084E	-	6.063	5.551	5.315	5.157	4.921	4.843	4.606	4.567	4.567
PL080X091E	7.205	6.378	5.906	5.669	5.512	5.276	5.197	5.000	5.000	5.000
PL085X096E	7.402	6.575	6.102	5.906	5.709	5.512	5.394	5.197	5.197	5.197
PL090X101E	-	7.913	7.126	6.772	6.496	6.220	6.063	5.748	5.551	5.394
PL095X106E	-	8.071	7.283	6.969	6.693	6.417	6.260	5.945	5.748	5.591
PL100X114E	8.858	7.835	7.244	6.969	6.772	6.496	6.378	6.142	5.945	5.906
PL110X124E	-	9.370	8.504	8.110	7.835	7.480	7.283	6.969	6.732	6.535
PL120X134E	-	9.646	8.819	8.465	8.189	7.835	7.677	7.362	7.126	6.929
PL130X148E	11.142	9.921	9.213	8.898	8.622	8.346	8.189	7.874	7.638	7.480
PL140X158E	11.457	10.315	9.606	9.291	9.055	8.740	8.583	8.268	8.031	7.874
PL150X168E	13.661	11.929	10.945	10.472	10.118	9.724	9.488	9.094	8.780	8.583

S e c t i o n F

Selection Table

Minimum Hub Diameter DN (inches)
Form Factor K3=0.8

Model Number	Yield Point of Various Hub Materials (p.s.i.)									
	21,000	25,000	30,000	32,000	35,000	40,000	43,000	50,000	57,000	64,000
PL010X013E	-	0.827	0.748	0.709	0.709	0.669	0.669	0.630	0.630	0.591
PL012X015E	-	0.906	0.866	0.827	0.787	0.787	0.748	0.748	0.709	0.709
PL013X016E	-	0.945	0.906	0.906	0.827	0.827	0.787	0.787	0.748	0.748
PL014X018E	-	1.024	0.984	0.945	0.945	0.906	0.906	0.866	0.827	0.827
PL015X019E	1.102	1.024	0.984	0.945	0.945	0.906	0.906	0.866	0.866	0.827
PL016X020E	1.142	1.063	1.024	0.984	0.984	0.945	0.945	0.906	0.906	0.906
PL017X021E	1.181	1.142	1.063	1.063	1.024	0.984	0.984	0.945	0.945	0.945
PL018X022E	1.220	1.142	1.102	1.102	1.063	1.024	1.024	0.984	0.984	0.984
PL019X024E	-	1.457	1.339	1.299	1.260	1.220	1.220	1.181	1.142	1.102
PL020X025E	-	1.496	1.378	1.339	1.299	1.260	1.260	1.220	1.181	1.142
PL022X026E	-	1.575	1.496	1.417	1.378	1.339	1.299	1.260	1.220	1.220
PL024X028E	1.654	1.535	1.457	1.417	1.378	1.339	1.339	1.299	1.260	1.260
PL025X030E	1.654	1.575	1.496	1.457	1.457	1.417	1.378	1.378	1.339	1.339
PL028X032E	1.969	1.811	1.732	1.693	1.654	1.575	1.575	1.496	1.496	1.457
PL030X035E	2.047	1.890	1.811	1.772	1.732	1.693	1.654	1.614	1.575	1.575
PL032X036E	2.087	1.929	1.850	1.811	1.772	1.732	1.693	1.654	1.614	1.614
PL035X040E	2.402	2.205	2.087	2.047	2.008	1.969	1.929	1.850	1.811	1.811
PL036X042E	2.441	2.244	2.165	2.087	2.047	2.008	1.969	1.929	1.890	1.850
PL038X044E	2.520	2.362	2.244	2.205	2.165	2.087	2.087	2.008	1.969	1.969
PL040X045E	-	2.717	2.559	2.480	2.402	2.323	2.283	2.205	2.126	2.087
PL042X048E	-	2.795	2.638	2.559	2.480	2.402	2.362	2.283	2.244	2.205
PL045X052E	3.110	2.874	2.717	2.677	2.598	2.520	2.480	2.441	2.362	2.323
PL048X055E	3.228	2.992	2.874	2.795	2.717	2.677	2.638	2.559	2.480	2.441
PL050X057E	3.307	3.110	2.953	2.874	2.835	2.756	2.717	2.638	2.598	2.559
PL055X062E	3.543	3.307	3.150	3.071	3.031	2.953	2.913	2.835	2.795	2.756
PL056X064E	3.780	3.543	3.346	3.268	3.189	3.110	3.071	2.992	2.913	2.874
PL060X068E	3.976	3.701	3.504	3.425	3.346	3.268	3.228	3.150	3.071	3.031
PL063X071E	-	4.409	4.094	3.937	3.858	3.701	3.622	3.504	3.386	3.307
PL065X073E	-	4.449	4.173	4.016	3.898	3.780	3.701	3.583	3.465	3.386
PL070X079E	-	4.685	4.370	4.252	4.134	4.016	3.937	3.819	3.701	3.622
PL071X080E	-	4.724	4.449	4.291	4.173	4.055	3.976	3.858	3.740	3.661
PL075X084E	-	4.803	4.567	4.409	4.331	4.173	4.134	3.976	3.898	3.819
PL080X091E	5.630	5.197	4.882	4.764	4.646	4.528	4.449	4.291	4.213	4.134
PL085X096E	5.866	5.394	5.118	4.961	4.882	4.724	4.646	4.528	4.409	4.331
PL090X101E	-	6.260	5.827	5.630	5.433	5.276	5.157	4.961	4.803	4.724
PL095X106E	-	6.417	6.024	5.787	5.630	5.472	5.354	5.157	5.039	4.921
PL100X114E	7.008	6.457	6.102	5.945	5.787	5.630	5.551	5.394	5.276	5.157
PL110X124E	-	7.480	7.008	6.772	6.575	6.378	6.260	6.024	5.866	5.748
PL120X134E	-	7.835	7.362	7.165	6.969	6.772	6.654	6.417	6.260	6.142
PL130X148E	8.976	8.307	7.874	7.638	7.480	7.283	7.165	6.969	6.811	6.693
PL140X158E	9.331	8.701	8.268	8.071	7.874	7.677	7.559	7.362	7.205	7.087
PL150X168E	10.748	9.803	9.252	8.937	8.740	8.465	8.307	8.071	7.874	7.717

Specifications

Consider these additional types of Power-Locks for your operation. Each is designed to provide keyless locking power for special applications. Consult Tsubaki Technical Support for more information on the Power-Locks shown below.

TF Series



Applicable shaft size: 18 to 90 mm

- Designed for hubs with smaller outside diameters.
- Self-centering function aligns the hub and shaft during installation.

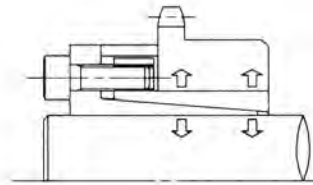

SL Series



Applicable shaft size: 19 to 245 mm

- Connects to the outside of the hub.
- Suited for applications where a thick hub is not possible.
- High transmissible torque.

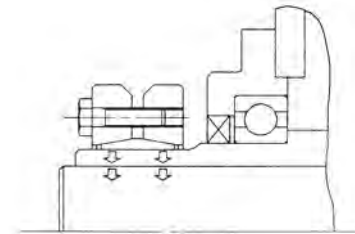

EF Series



Applicable shaft size: 10 to 120 mm

- Same inner and outer diameter as the EL Series.
- Small ratio between inner and outer diameters allows for smaller hub diameters.

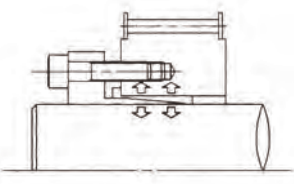

RE Series



Applicable shaft size: 5 to 50 mm

- Stainless steel construction.
- Designed with a convenient removable flange.
- Excellent for small shaft diameters.

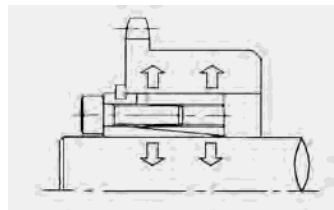

with Flange

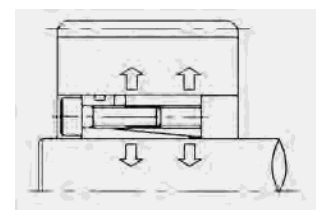

without Flange

Introduction

Our prefabricated steel doors seal out dust and rain but permit line inspections simply by lifting the handle — with no bolts to loosen and no covers to misplace. A variety of sizes and styles are in-stock and ready-to-go for quick and easy installation at the jobsite. You can't build better access to your lines.

- Easy to install
- Easy to open and close
- Durable and trouble-free
- Dust and rain-tight

Need a special size or extra handles?
Do you want to change the location of handles or hinges?

Contact Tsubaki. We can work with you on special requirements.

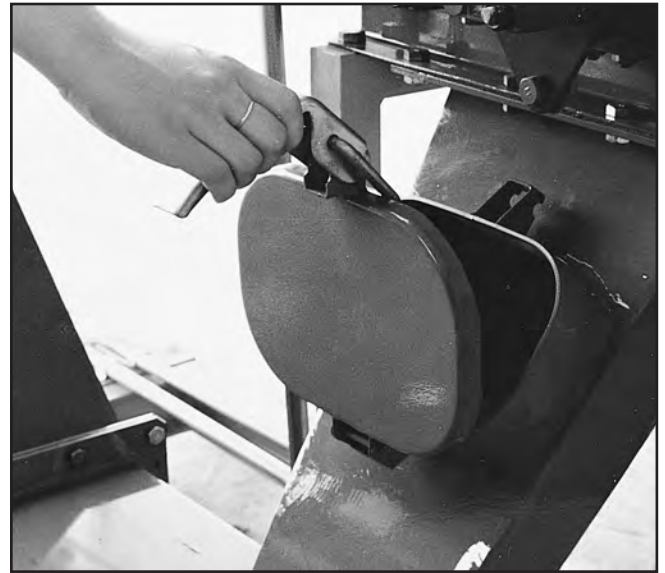

Standard Model

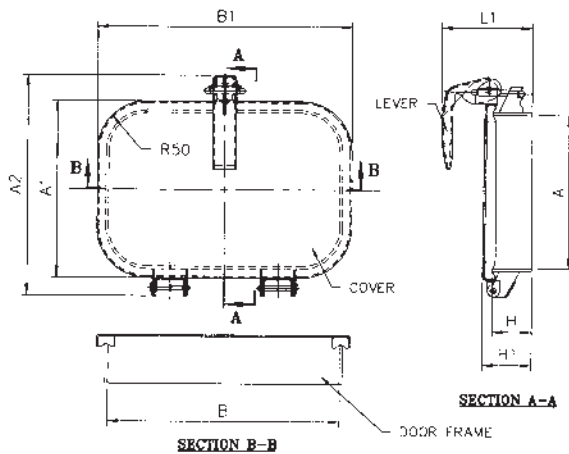

Large Model

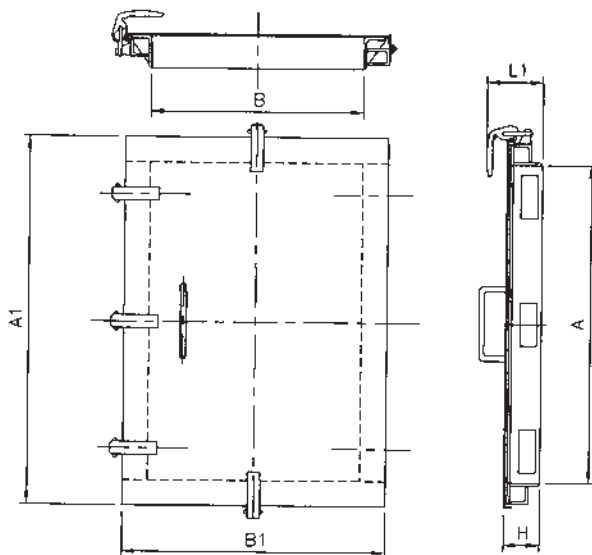

ONE-TOUCH INSPECTION DOOR® is a registered trademark of Tsubaki Conveyor of America, Inc.

Specifications

Material Thickness

Frame: 10 gauge
Cover: 13 gauge

Component Composition

Model Number	Body Material	Handle Material
P Series	Mild steel	Chrome-plated
Q Series	304 Stainless	Chrome-plated
R Series	304 Stainless	304 Stainless
QS Series*	316L Stainless	Chrome-plated
RS Series*	316L Stainless	304 Stainless

Gasket Options

Polyethylene (SG)
Epichlorhydrin (ECH)
Silicon Rubber (HT)

Temperature Range

-95° F to 175° F
-40° F to 275° F
-67° F to 400° F

Standard ONE-TOUCH INSPECTION DOOR Specifications

Dimensions are in inches unless otherwise indicated.

Style/ Model Number		Door Frame				Cover				Lever			Approx. Weight (lbs.)		
		A	B	Std.	High Neck	A1	A2	B1	High Neck	Std.	High Neck	Qty.			Std.
Regular	High Neck												H	H1	
Mild Steel Body, Chrome-Plated Handle															
P1	P1H	5	8	2	4	6 1/4	8 1/2	9	2 1/2	4 1/2	4 1/2	6 1/2	1	4.5	6
P2	P2H	8	12	2	4	9	11 1/4	13	2 1/2	4 1/2	4 1/2	6 1/2	1	6.6	9.2
P3	P3H	13 3/4	19 3/4	2	4	15	17 1/4	20 3/4	2 1/2	4 1/2	4 1/2	6 1/2	2	13.2	17.6
P4		19 3/4	23 1/2	3	N/A	20 3/4	23 1/4	24 3/4	3 1/2	5 1/2	4 1/2	N/A	2	24.2	N/A
304 Stainless Steel Body, Chrome-Plated Handle															
Q1	Q1H	5	8	2	4	6 1/4	8 1/2	9	2 1/2	4 1/2	4 1/2	6 1/2	1	4.5	6
Q2	Q2H	8	12	2	4	9	11 1/4	13	2 1/2	4 1/2	4 1/2	6 1/2	1	6.6	9.2
Q3	Q3H	13 3/4	19 3/4	2	4	15	17 1/4	20 3/4	2 1/2	4 1/2	4 1/2	6 1/2	2	13.2	17.6
Q4		19 3/4	23 1/2	3	N/A	20 3/4	23 1/4	24 3/4	3 1/2	5 1/2	4 1/2	N/A	2	24.2	N/A
304 Stainless Steel Body, 304 Stainless Steel Handle															
R1	R1H	5	8	2	4	6 1/4	8 1/2	9	2 1/2	4 1/2	4 1/2	6 1/2	1	4.5	6
R2	R2H	8	12	2	4	9	11 1/4	13	2 1/2	4 1/2	4 1/2	6 1/2	1	6.6	9.2
R3	R3H	13 3/4	19 3/4	2	4	15	17 1/4	20 3/4	2 1/2	4 1/2	4 1/2	6 1/2	2	13.2	17.6
R4		19 3/4	23 1/2	3	N/A	20 3/4	23 1/4	24 3/4	3 1/2	5 1/2	4 1/2	N/A	2	24.2	N/A
316L Stainless Steel Body, Chrome-Plated Handle															
QS1	QS1H	5	8	2	4	6 1/4	8 1/2	9	2 1/2	4 1/2	4 1/2	6 1/2	1	4.5	6
QS2	QS2H	8	12	2	4	9	11 1/4	13	2 1/2	4 1/2	4 1/2	6 1/2	1	6.6	9.2
QS3	QS3H	13 3/4	19 3/4	2	4	15	17 1/4	20 3/4	2 1/2	4 1/2	4 1/2	6 1/2	2	13.2	17.6
316L Stainless Steel Body, 304 Stainless Steel Handle															
RS1	RS1H	5	8	2	4	6 1/4	8 1/2	9	2 1/2	4 1/2	4 1/2	6 1/2	1	4.5	6
RS2	RS2H	8	12	2	4	9	11 1/4	13	2 1/2	4 1/2	4 1/2	6 1/2	1	6.6	9.2
RS3	RS3H	13 3/4	19 3/4	2	4	15	17 1/4	20 3/4	2 1/2	4 1/2	4 1/2	6 1/2	2	13.2	17.6

Note: Dimensions are rounded to the nearest 1/4".

Large Model Specifications One Touch Door

Material Thickness

Frame: 1/4"
Cover: 10 gauge

Component Composition

L Series	Options
Body material	Mild steel, Stainless steel*
Lever material	Mild steel, Stainless steel*
Body finish	Rust-proof, one-coat
Handle finish	Chrome-plated
Gasket options	Neoprene rubber, Silicon rubber

Gasket Options

Neoprene Rubber
Silicon Rubber (HT)

Temperature Range

-20° F to 160° F
-80° F to 550° F

Large ONE-TOUCH INSPECTION DOOR Specifications

All dimensions are in inches unless otherwise indicated.

Model Number	Door Opening		Cover			Lever	Quantity	Approximate Weight (lbs.)
	A	B	A1	B1	H	L1		
L1	29 1/2	19 3/4	34 1/4	24 1/2	3 1/4	5 1/4	5	80
L2	39 1/4	25 1/2	44	30 1/4	3 1/4	5 1/4	6	111
L3	47 1/4	31 1/2	52	36 1/4	3 1/4	5 1/4	8	140.8

Note: Dimensions rounded to the nearest 1/4".

Introduction

Pro-Align lets you align all power transmission devices faster, easier, and more effectively than ever before. System misalignment is a leading cause of premature chain wear. Our advanced laser technology ensures precise chain-sprocket interaction for maximum performance.

- Chain life is extended
- Shafts and bearings last longer
- Friction and vibration is lower, using less energy
- Cost and inventory levels are reduced

Increase Productivity

Conventional alignment methods can be difficult to position, inaccurate, and produce erratic results — costing you valuable production time. Pro-Align gets the job done fast. It sets up easily — even in tight spaces — and eliminates the backlash effects of water, shock, and corrosion. You get reliable readings right away and can quickly get back to business.

- Requires minimal downtime, maintenance, and training
- Adapts to your equipment with no costly reconfiguration
- Accurate within 1/8" in 100 feet for precision applications
- Maintains accuracy under the toughest operating conditions
- Compact, lightweight, portable unit



Laser

The Pro-Align laser activates with a simple twisting motion. The level adapts to horizontal, vertical, inclined, or restricted measurement units with no costly reconfiguration.



Target

Pro-Align's custom aluminum target is specifically calibrated to the laser to provide immediate, reliable readings.

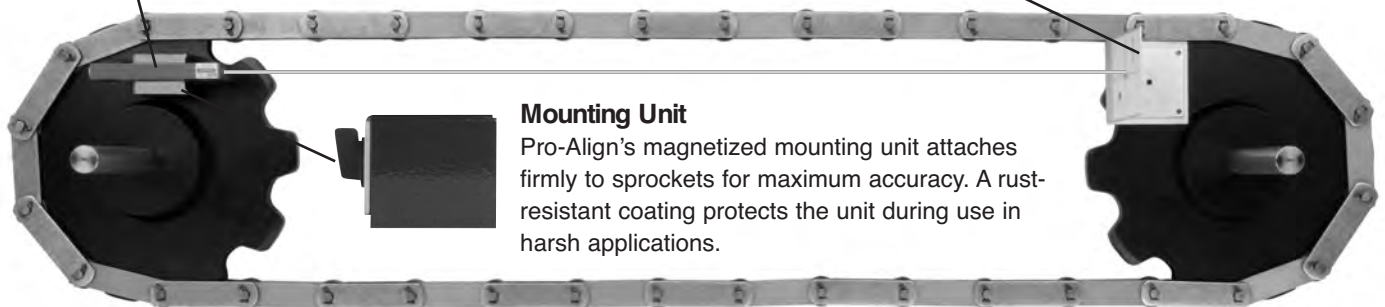

Mounting Unit

Pro-Align's magnetized mounting unit attaches firmly to sprockets for maximum accuracy. A rust-resistant coating protects the unit during use in harsh applications.

 **WARNING****USE CARE TO PREVENT INJURY
COMPLY WITH THE FOLLOWING
TO AVOID SERIOUS PERSONAL INJURY**

1. Guards must be provided on all chain and sprocket installations in accordance with provisions of ANSI/ASME B15.1 - 1996 "Safety standards for Mechanical Power Transmission Apparatus," and ANSI/ASME B20.1 - 1996 "Safety Standards for Conveyors and Related Equipment," or other applicable safety standards. When revisions of these standards are published, the updated edition shall apply.
2. Always lock out power switch before installing, removing, lubricating or servicing a system which uses PTUC products.
3. When connecting or disconnecting PTUC products, eye protection is required. Wear safety glasses, protective clothing, gloves and safety shoes.

*PTUC is used by Tsubaki to designate "Power Transmission Unit Components."

Rev. 6-98

Chain Number	Chain Type	Page #
TSBSS05	Analogue Shock Relay - "SS" Series	F-3
TSBSS30	Analogue Shock Relay - "SS" Series	F-3
TSBSS60	Analogue Shock Relay - "SS" Series	F-3
TSBSS100	Analogue Shock Relay - "SS" Series	F-5
TSBSS200	Analogue Shock Relay - "SS" Series	F-5
TSBSS300	Analogue Shock Relay - "SS" Series	F-5
TSBSD10	Digital Shock Relay - "SD" Series	F-6
TSBSD60	Digital Shock Relay - "SD" Series	F-6
TSB3CT100	Digital Shock Relay - "SD" Series	F-9
TSB3CT200	Digital Shock Relay - "SD" Series	F-9
TSB3CT300	Digital Shock Relay - "SD" Series	F-9
-	Power-Lock - AS Inch Series	F-17
-	Power-Lock - AS Metric Series	F-18
-	Power-Lock - AD Metric Series	F-21
-	Power-Lock - KE Inch Series	F-24
-	Power-Lock - AE Metric Series	F-27
-	Power-Lock - EL Metric Series	F-30
-	Power-Lock - Specialty (TF/SU/EF/RE)	F-34
-	One-Touch Inspection Door®	F-36
-	Pro-Align® Laser Alignment System	F-37

These Terms and Conditions of Sale and, where applicable, the quotation, sales order confirmation, invoice and all documents incorporated expressly by reference therein shall constitute the entire agreement governing the sale of the Seller's products (the "Contract").

PRICE-PAYMENT

The prices stated are those in effect on the date hereof and are subject to change based on prices in effect on the date of shipment. Interest at the rate of the lesser of (i) 18% per annum, or (ii) the maximum rate allowable by applicable law, shall be charged on overdue payments. Prices are for Seller's standard packaging only, and F.O.B. Seller's plant or warehouse. All orders are subject to credit approval. Terms of payment are net, 30 days. In the event of non-payment by Buyer, Buyer shall pay all of Seller's costs of collection, including reasonable legal fees.

PERFORMANCE-CHANGES-DELAYS

- (a) Any time for delivery stated herein is approximate. Delivery shall be deemed complete by tender of the products to a common carrier. Partial shipments are permitted.
- (b) Orders are not subject to cancellation or revision, in whole or in part, without written approval of Seller and the payment of the applicable cancellation charges and expenses, if any, levied by the Seller.
- (c) Should Buyer cause changes to be made in the design or construction of any products, or otherwise delay or interrupt the progress of the work hereunder, Buyer will reimburse Seller for any additional costs arising therefrom.
- (d) Seller shall not be liable for any delay caused by acts of God, riot or civil commotion, government orders, rules, regulations, suspensions or requisitions of any kind, strikes or other stoppages of labor or shortage in the supply of labor or material, fire casualties or accidents, or any cause, whether of the same or a different character, beyond Seller's control. Any such delay shall extend the time for delivery of the products. Delay in delivery of any installment shall not relieve Buyer of its obligation to accept remaining deliveries.
- (e) If delays due to Buyer's fault exceed 60 days in the aggregate, the entire purchase price shall be due and payable to Seller on demand.
- (f) Any claim relating to quantity or type of products ordered or shipped to Buyer shall be made to Seller in writing within 7 days after Buyer's receipt of the products and any such claim made thereafter shall be barred.

RISK OF LOSS

After delivery to the carrier, Buyer assumes the risk of all loss or damage to the products resulting from any cause whatever.

LIMITED WARRANTY

Seller makes the following limited warranty:

Seller warrants all products manufactured and sold by it (excluding all items not manufactured by Seller, such as trade accessories, that may be sold with, attached to, or operated with Seller's products), to (i) for products manufactured to the specifications of Buyer, conform to the agreed written specifications, if any, for such products, and/or (ii) be free from material defects in material and workmanship under normal use and service for twelve (12) months from the date of shipment from the Seller's factory to the original purchaser. Any claim under this Limited Warranty shall be made to Seller in writing within three (3) months after the date of shipment of the products and any such claim made thereafter shall be barred. SELLER'S ENTIRE OBLIGATION AND LIABILITY, AND BUYER'S EXCLUSIVE REMEDY, UNDER THIS WARRANTY IS LIMITED TO THE REPLACEMENT OR REPAIR, IN SELLER'S SOLE DISCRETION, AT THE FACTORY OF SELLER OR AT A POINT DESIGNATED BY IT, OF SUCH PRODUCTS AS SHALL APPEAR TO SELLER UPON INSPECTION AT SUCH POINT TO HAVE BEEN DEFECTIVE IN MATERIAL OR WORKMANSHIP AT THE TIME SOLD, PROVIDED THAT THE PRODUCT OR PRODUCTS CLAIMED DEFECTIVE ARE RETURNED TO THE SELLER DESIGNATED INSPECTION POINT, TRANSPORTATION CHARGES PREPAID BY THE BUYER, WITHIN THE ABOVE-NOTED WARRANTY PERIOD.

This Contract will not be deemed to have failed of its essential purpose and there shall be no fundamental breach of this Contract so long as Seller is willing and able to replace or repair any defective product in the manner prescribed above.

This limited warranty applies only to new and unused products which after shipment from the Seller's factory have not been altered, changed or replaced in any manner.

If, after inspection of the returned products, Seller determines that the defect is a result of misuse, mishandling, installation, abnormal conditions of operation, unauthorized repair or modification, or due to the Buyer's failure to install, maintain or operate the product in compliance with the written instructions, then the Buyer shall reimburse Seller for all expenses incurred by Seller in connection with the replacement or repair of the product. Any product returned to Seller for replacement shall become the property of Seller.

The Buyer shall be responsible for all costs of shipping, customs clearance and other related charges in connection with Seller's replacement or repair of products located outside of Canada pursuant to this limited warranty.

DISCLAIMER OF WARRANTIES:

THE WARRANTIES, GUARANTEES, REPRESENTATIONS AND CONDITIONS SET OUT SPECIFICALLY ABOVE UNDER THE HEADING "LIMITED WARRANTY" ARE IN LIEU OF ALL OTHER WARRANTIES, GUARANTEES, REPRESENTATIONS AND CONDITIONS, WHETHER BY SELLER OR THIRD PARTIES, EXPRESS OR IMPLIED, INCLUDING, BUT NOT LIMITED TO, THE IMPLIED WARRANTIES OR CONDITIONS OF MERCHANTABILITY AND FITNESS FOR A PARTICULAR PURPOSE AND THOSE ARISING BY STATUTE OR OTHERWISE IN LAW OR FROM A COURSE OF DEALING OR USAGE OF TRADE. NO

WARRANTY, GUARANTEE, REPRESENTATION OR CONDITION, EXPRESS OR IMPLIED, MADE BY ANY DISTRIBUTOR, SALES REPRESENTATIVE, FIELD AGENT OR EMPLOYEE OF SELLER WHICH IS NOT SPECIFICALLY SET FORTH HEREIN SHALL BE BINDING ON SELLER.

LIMITATION OF LIABILITY

IN NO EVENT SHALL SELLER, ITS AFFILIATES OR THEIR RESPECTIVE DIRECTORS, OFFICERS, EMPLOYEES, REPRESENTATIVES, AGENTS OR SUPPLIERS BE LIABLE TO BUYER OR ANY THIRD PARTY (INCLUDING ANY SUBSEQUENT ACQUIRER) FOR ANY INDIRECT, INCIDENTAL, SPECIAL, CONSEQUENTIAL, PUNITIVE OR EXEMPLARY DAMAGES (INCLUDING, BUT NOT LIMITED TO, DAMAGES RESULTING FROM PERSONAL INJURY OR DEATH, DAMAGE TO OR LOSS OF PROPERTY OR EQUIPMENT, BUSINESS INTERRUPTION, LOSS OF REVENUE OR PROFIT AND HARM TO GOODWILL OR BUSINESS REPUTATION) WHETHER BASED IN BREACH OF CONTRACT (INCLUDING FUNDAMENTAL BREACH OR BREACH OF A FUNDAMENTAL TERM), TORT (INCLUDING NEGLIGENCE) OR OTHERWISE IN LAW OR EQUITY, ARISING OUT OF OR IN CONNECTION WITH ANY MATTER RELATING TO THIS CONTRACT OR ANY OTHER CONTRACT OF SALE BETWEEN THE SELLER AND THE BUYER OR TO THE PRODUCTS, EVEN IF ADVISED OF THE POSSIBILITY OF SUCH DAMAGES.

IN NO EVENT SHALL THE MAXIMUM LIABILITY OF SELLER, ITS AFFILIATES OR THEIR RESPECTIVE DIRECTORS, OFFICERS, EMPLOYEES, REPRESENTATIVES, AGENTS OR SUPPLIERS, IN THE AGGREGATE, EXCEED THE AMOUNT PAID BY BUYER TO SELLER TO PURCHASE THE SPECIFIC PRODUCTS PROVIDED BY THE SELLER THAT GIVE RISE TO THE CLAIM OR CAUSE OF ACTION.

NON-RELIANCE

Buyer is not relying upon any advice, representations or warranties (except the warranties expressly set forth above) of Seller, or upon Seller's skill or judgment regarding the Seller's products. Buyer is solely responsible for the design and specifications of the products, including without limitation, the determination of suitability for Buyer's application of the products.

INDEMNIFICATION

Buyer will indemnify, defend and hold Seller harmless from all loss, liability, damage and expense, including legal fees, arising out of any claim (a) for infringement of any intellectual property right of any third party, including without limitation, patent, trademark, copyright, misappropriation of trade secrets, unfair competition or similar charge, by any products supplied to Seller by Buyer or supplied by Seller to Buyer in accordance with the designs or specifications, or other instructions, of Buyer, or (b) arising out of or connected with: (i) the use of the products, or (ii) any items into which the products are incorporated, including, but not limited to, any claim for product liability (whether or not based on negligence or strict liability of Seller), breach of warranty, breach of contract or otherwise.

DUTIES AND TAXES

In addition to the specified purchase price, Buyer will pay any and all federal, provincial or local taxes, duties, excises, license fees and other charges leveled, assessed or imposed upon Seller due to the manufacture, sale, purchase or delivery of the products. Buyer shall also pay the cost by which such manufacture is increased by reason of any law, ordinance or regulation adopted or promulgated by any government or governmental subdivision, department or agency, or other source, after the date hereof, but prior to the completion and delivery hereunder.

SPECIFICATIONS, DRAWINGS, PATTERNS AND TOOLS

Seller's specifications, drawings, patterns and tooling shall be the sole and exclusive property of Seller unless otherwise agreed in writing.

ENTIRE AGREEMENT

This Contract constitutes the entire agreement between Buyer and Seller with respect to the subject matter of this Contract, and supercedes any other, whether made heretofore or hereafter, (i) agreement or discussion, oral or written, express or implied, and (ii) any, inconsistent terms and conditions whether contained in Buyer's purchase order or otherwise. Other than with respect to alternate "Price-Payment" terms agreed to in writing by Seller, no (i) change, modification, or waiver of these Terms and Conditions of Sale, or (ii) conditions, usage or trade, course of dealing or performance, understanding or agreement purporting to change, modify, supplement, vary, explain or waive any of these Terms and Conditions of Sale, shall be binding upon the Seller unless made in writing, where such writing makes specific reference to these Terms and Conditions of Sale and has been signed by an authorized representative of the party against which enforcement thereof is sought. Seller reserves the right to change these Terms and Conditions of Sale without prior notice.

RETURNED GOODS

No goods will be accepted for return without prior written authorization by Seller. Freight must be prepaid on all such returns, and each return is subject to inspection and acceptance by Seller to assure the goods are in a "resalable" condition. A minimum 15% handling and restocking charge will be applied to all authorized returns. Special or made-to-order goods are NOT returnable. Attachment chains returned are at the manufacturer's discretion.

GOVERNING LAW

This Contract shall be governed by and construed in accordance with the laws of the Province of Ontario and the federal laws applicable therein (excluding any conflict of laws rule or principle which might refer such construction to the laws of another jurisdiction) and Buyer and Seller expressly exclude the application of the United Nations Convention on Contracts for the International Sale of Goods.

MISCELLANEOUS

If any provision of this Contract is declared by a court of competent jurisdiction to be invalid, illegal or unenforceable, such provision shall be severed from this Contract and the other provisions shall remain in full force and effect, unless such invalid provisions are held to be a material part of this Contract such that it may be reasonably assumed that the parties would not have entered into this Contract without such provisions in place. No waiver by Seller with respect to any breach or default or any right or remedy and no course of dealing, shall be deemed to constitute a continuing waiver of any other breach or default or of any other right or remedy, unless such waiver is specifically expressed in writing and is signed by the party to be bound thereof. Buyer shall not assign this contract, or any of its rights or obligations hereunder, without the prior written consent of the Seller. The parties hereto have requested that this Contract and all correspondence and all documentation respecting this Contract be written in the English language. Les parties aux présentes ont exigé que la présente entente, de même que toute la correspondance et la documentation relative à cette entente, soient rédigées en langue anglaise.

Tsubaki of Canada Limited ©All rights reserved. (April 21, 2005)