

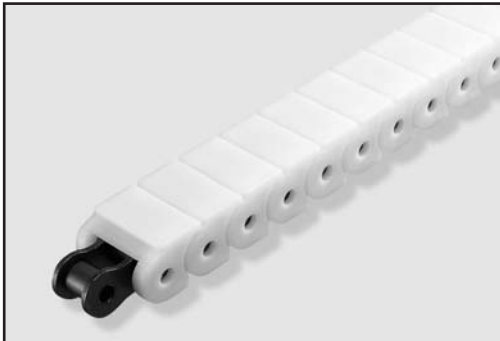

# Tsubaki Plastic Snap Cover Chain

## Plastic Snap Cover Chain



Tsubaki Snap Cover Chain is standard roller chain with an engineering plastic cover attached to each link. It has the same allowable tensile strength as steel chain while allowing (even fragile) materials and products to be placed directly onto the chain without concern of damage.

Snap Cover Chain can be used for heavy load and long conveyor line applications previously not possible with standard RS series plastic chain. For the user, this means lower conveying costs and enhanced productivity. The innovative snap cover design features engineering thermoplastic covers that fit together seamlessly and securely over the pins on each link of the steel base chain. (Cotter pins/spring clips are not used. The "legs" of the plastic snap cover are used to hold down the connecting link plate and to prevent it from becoming loose).

The flexibility of the design means that the base chain can be either Tsubaki's standard carbon steel roller chain or, for "clean" applications where lubrication is difficult or not permitted, Tsubaki's lube-free Lambda series. Another option is a stainless steel (SS) base chain for operating environments where corrosion could be a problem.

There are two options in the choice of plastic covers: white polyacetal (standard/general usage) and black electro-conductive (preventing static/dust build-up).

Snap cover chain is available in six pitch sizes, and is designed for use at running speeds up to 200 ft./min in the temperature range from -14°F and +176°F.

In common with all Tsubaki chain products, the operation, assembly, disassembly and recycling of Snap Cover Chain is simple and efficient. The resin cover is simply removed using a screwdriver and the connecting link pins and plates are all loose fitting.

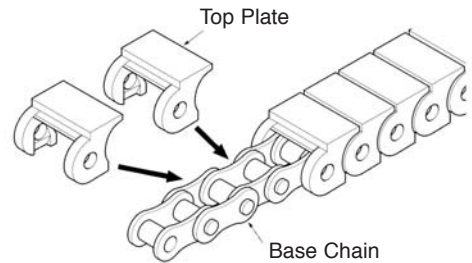
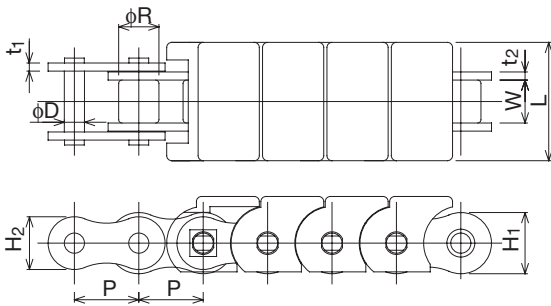

All dimensions in inches unless otherwise stated.

Carbon Steel Chain Number	Lambda Chain Number	(SS) Stainless Steel Chain Number	Pitch P	Roller Dia. R	Width Between Inner Link Plates W	Link Plate				Pin Dia. D
						Thickness $t_1$	Thickness $t_2$	Height $H_1$	Height $H_2$	
*RF06B-SC	-	*RF06BSS-SC	0.375	0.250	0.225	0.039	0.050	0.323	0.323	0.129
RS40-SC	RSC40-LAMBDA-SC	RS40SS-SC	0.500	0.312	0.313	0.059	0.059	0.472	0.409	0.156
RS50-SC	RSC50-LAMBDA-SC	RS50SS-SC	0.625	0.400	0.375	0.079	0.079	0.591	0.512	0.200
RS60-SC	RSC60-LAMBDA-SC	RS60SS-SC	0.750	0.469	0.500	0.094	0.094	0.713	0.614	0.235
RS80-SC	RSC80-LAMBDA-SC	RS80SS-SC	1.000	0.629	0.625	0.126	0.126	0.949	0.819	0.313
RS100-SC	RSC100-LAMBDA-SC	RS100SS-SC	1.250	0.750	0.750	0.157	0.157	1.185	1.024	0.376

Carbon Steel Chain Number	Lambda Chain Number	(SS) Stainless Steel Chain Number	Plastic Cover			(Carbon Steel and Lambda) Maximum Allowable Load (lbs.)	(Stainless Steel) Maximum Allowable Load (lbs.)	Approx. Weight (lbs./ft.)	Number of Links per 10 Feet
			Height $h_1$	Height $h_2$	Length L				
*RF06B-SC	-	*RF06BSS-SC	0.173	0.291	0.689	330	60	3.2	320
RS40-SC	RSC40-LAMBDA-SC	RS40SS-SC	0.236	0.374	0.925	600	100	5.8	240
RS50-SC	RSC50-LAMBDA-SC	RS50SS-SC	0.295	0.457	1.142	970	155	9.5	192
RS60-SC	RSC60-LAMBDA-SC	RS60SS-SC	0.335	0.543	1.378	1,410	230	13.8	160
RS80-SC	RSC80-LAMBDA-SC	RS80SS-SC	0.453	0.709	1.634	2,405	400	23.6	120
RS100-SC	RSC100-LAMBDA-SC	RS100SS-SC	0.579	0.839	1.909	3,845	575	37.7	96

\* RF06B has a flat shaped link plate. This chain uses standard ANSI sprockets.

# Snap Cover Chain Selection and Maintenance

## 1. Chain size

Chart 1: Allowable load (lbs per link)

	RF06B-SC	RS40-SC	RS50-SC	RS60-SC	RS80-SC	RS100-SC
Allowable Load	6.6	11	15.4	22	33	55

(1) Confirm that the load per link is within the allowable load, for the chain size, shown in chart 1.

(2) Calculation of Load applied to the chain

F	= Maximum load applied to chain	(lbs)
m1	= Weight of conveyed materials	(lbs/ft)
m2	= Chain weight	(lbs/ft)
S	= Conveyor length (Distance between sprocket centers)	(ft)
S'	= Distance of conveyed materials slip and stop	(ft)
$\mu_1$	= Coefficient of Friction between chain and guide rail (Conveying side)	(Chart 2)
$\mu_2$	= Coefficient of Friction between chain and guide rail (Return side)	(Chart 3)
$\mu_3$	= Coefficient of Friction between conveyed materials and chain	(Chart 4)
P	= Required power	(HP)
V	= Chain speed	(ft/min)
K	= Speed coefficient	(Chart 5)
$\eta$	= Mechanical transmission efficiency of drive unit	
G	= $9.80665\text{m/s}^2$	

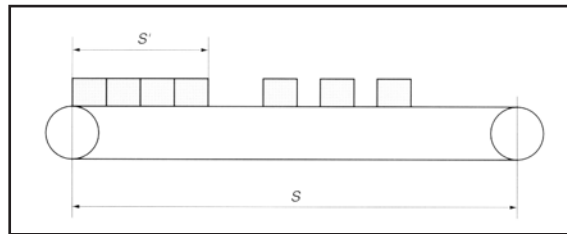

Chart 2: Coefficient of friction between chain and guide rail on conveying side ( $\mu_1$ )

Non-lubricated	Lubricated
0.21	0.14

Chart 3: Sliding coefficient between chain (Cover) and guide rail on return side ( $\mu_2$ )

Cover Material	Guide Rail Material	
	Stainless Steel	Ultra High polymer polyethylene
Polyacetal/Electro-conductive	0.25	0.25

Chart 4 : Coefficient of Sliding Friction between conveyed materials and chain (Cover) \*When non-lubricated

Cover Material	Conveyed Products Material				
	Steel & Aluminum Cans	Paper carton	Glass bottles	Plastic container	Manufacturing parts (metal)
Polyacetal / Electro-conductive	0.3	0.3	0.2	0.3	0.3

Chart 5 : Speed coefficient (K) \*When non-lubricated

Chain speed (ft./min.)	Speed coefficient K
Less than 50	1.0
50 ~ 100	1.2
100 ~ 167	1.4
167 ~ 200	1.6

# Snap Cover Chain Selection and Maintenance

Calculation formula

$$F = \{(m1 + m2) S \times \mu1 + 1.1m2 \times S \times \mu2 + m1 \times S' \times \mu3\}$$

Multiply the Maximum Chain Tension (F) by the Speed coefficient (K) (refer to Chart 5) and verify that the following equations are satisfied:

Single strand conveyor:  $F \times K \leq \text{Chain's Maximum Allowable Tension}$

Double strand conveyor:  $0.6F \times K \leq \text{Chain's Maximum Allowable Tension}$

## 2. Calculation of required Power

$$P = (F \times V) / (3000 \times \eta)$$

## Chain Cutting and Connecting

### 1) Engineering Plastic Cover

The cover can be removed by hand, however it is more easily removed using a screwdriver. When attaching the cover, ensure that it is securely fitted to the base chain.

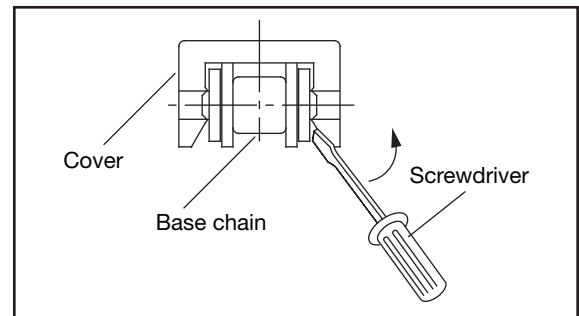

### 2) Disassembly of Base Chain

The connecting link pins and link plates are loose fitted. For all other links please use a punch and a hammer to remove the sets of pins. Disassembled links, other than the connecting link, cannot be used again.

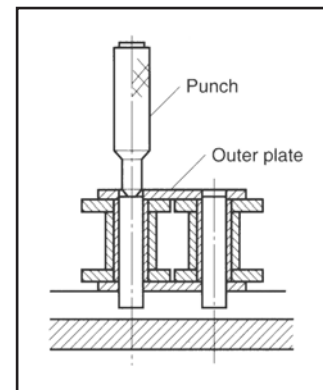

## Conveyor Setup

### 1) Running Rail

So as to prevent chain vibration and conveyor motion pulsation, gently bend the receiving rail on the slack side to allow easy reception of the chain.

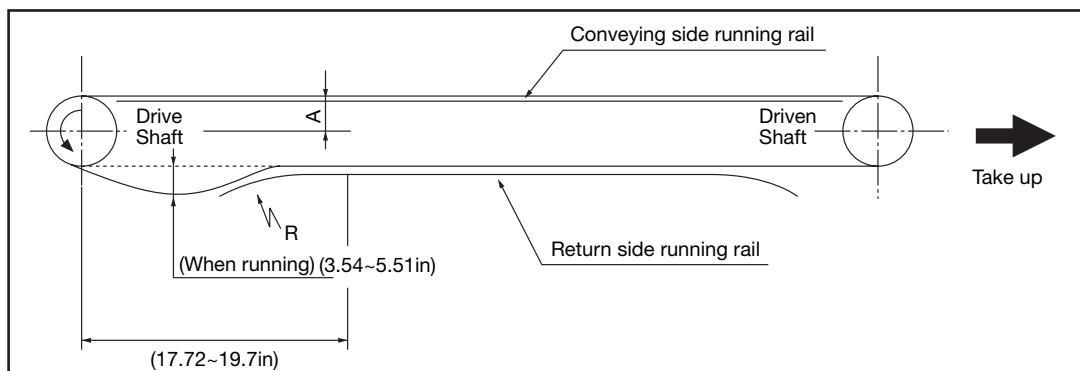

# Snap Cover Chain Selection and Maintenance

## 2) Chain Slack

Chain slack under the drive sprocket of 3.54" - 5.54" is required (when running).

Height of running rail

$$A = (\text{Sprocket pitch diameter} - \text{Roller diameter}) / 2$$

## 3) Bending of Running Rail Ends

The running rail R dimension should be larger than the chain's backbend radius R (Shown in the chart below).

All dimensions in inches unless otherwise stated.

	RF06B-SC	RS40-SC	RS50-SC	RS60-SC	RS80-SC	RS100-SC
Minimum backbend radius R	11	14.2	18.9	22	29.1	34.6

## 4) Chain Guide

a) Conveying side... Ensure that only the roller runs on the guide. If the cover runs on the guide it will wear quickly.

b) Return side... Run the whole surface of the cover on the guide.

### Conveying Side

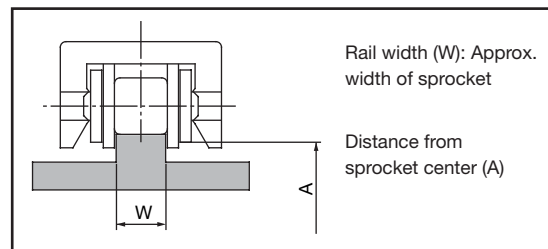

### Return Side

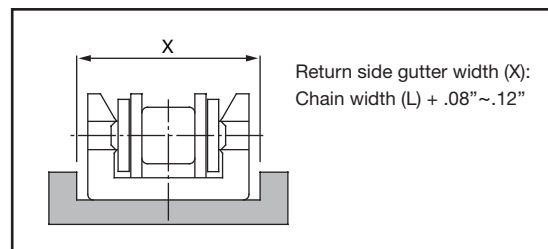

## Tsubaki of Canada Limited

1630 Drew Road, Mississauga, Ontario L5S 1J6

Tel: 905-676-0400 or 800-263-7088 Fax: 905-676-0904

info@tsubaki.ca www.tsubaki.ca