



# SPROCKETS

## Product Catalog

[www.tsubaki.ca](http://www.tsubaki.ca)

## Markets and Applications

Tsubaki sprockets are utilized worldwide in many markets and applications, including:

- Oil and Gas
- Lumber
- Mining
- Primary Metals
- Material Handling
- Conveyor
- Civil Engineering Projects
- Machine Tool
- Marine
- Packaging Machinery
- Pulp and Paper
- Food Processing
- Forestry



# SPROCKET SOLUTIONS MADE-TO-ORDER

## Tsubaki MTO Sprockets

Tsubaki, and its affiliates, have designed and manufactured Made-To-Order sprockets for over 35 years. Extensive design, engineering, and manufacturing capability allow Tsubaki to produce a wide variety of MTO sprocket products for a multitude of applications. From one-off custom to high volume OEM sprocket requirements, Tsubaki has you covered.



*Large Engineering Class  
Segmental Sprocket with Split Hub*

## Engineering Capabilities

Tsubaki has a broad range of engineering capabilities that enable the manufacture of complex MTO sprockets for your application requirements. Some of these capabilities include:

- System design assessments
- 2D/3D Cad Drawing Generation
- ECD, ANSI, and British Standard Design
- Custom tooth profiling
- Solid, split, segmental, adjustable design



*Triple roller chain sprocket with large  
finished bore and custom split design*



*Large Engineering Class Sprocket  
incorporating "Gap Tooth"  
design for drive chain attachments*



*Adjustable Segmental  
Rim Sprockets*

## Machining Capabilities

Tsubaki's range of machining capabilities provides sprocket solutions for large and small quantities. Tsubaki has the capability to economically create one-off custom sprockets or high volume production type units. Some of our core capabilities include:

- CNC/turning to 99" diameter
- Three-axis machining, 110" x 40" x 36"
- Traditional tooth hobbing to 60" diameter
- Induction and flame hardening to 120" diameter
- Machining of exotic metals
- Spline bore
- High tolerance finished bore
- Solid, welded, or web style sprockets



*Spline Bore Drive Sprocket*

## Sprocket Wear Indicator Technology

Tsubaki Sprocket Wear Indicator Technology assures maximum uptime and drive system efficiency by providing visual confirmation of excessive sprocket wear. Incorporating this patented technology into MTO, ANSI, or Engineering Class sprockets reduces overall system cost by offering predictable maintenance intervals to avoid catastrophic failure. Tsubaki Wear Indicator technology is available on ANSI 100 through 240 pitch, and Engineering Class sprockets with pitch lengths of greater than 4 inches. Applicable sprocket configurations are as follows:

- Type A (no hub extension) Plain or Finished Bore
- Type B (hub extension – one side) Plain or Finished Bore
- Type C (hub extension – both sides) Plain or Finished Bore
- TAPER-LOCK® and QD® Bushing Sprockets
- Split Taper Sprockets
- Multi-Strand Sprockets
- Stainless Steel Sprockets

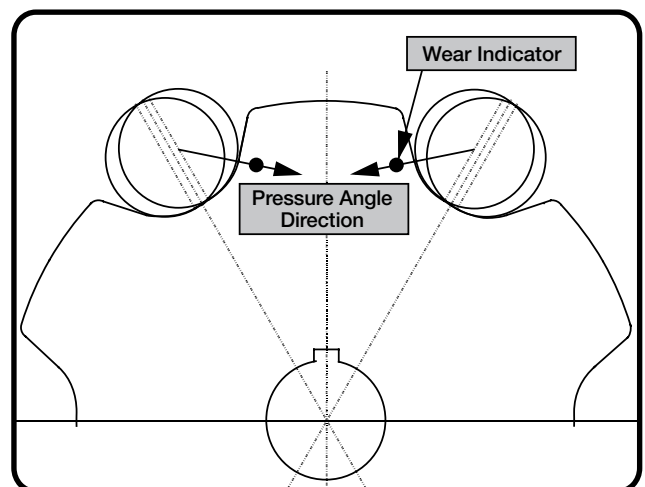

# SPROCKETSOLUTIONS

## Customer Support

Tsubaki's trained and experienced customer service team, application engineers, field sales network, and design engineers ensure that you will get accurate and timely support for all of your power transmission needs. Tsubaki has global representation in over 70 countries around the world, providing comprehensive support required by our customers and markets we serve.



## Distribution Network

Tsubaki has partnered with over 1,500 National and Independent distributors in North America to assure that our products are readily available and supported in all of the geographical regions served. Our distributor network is trained on all of the Tsubaki products, and can offer the support and service you need to stay up and running.



# TABLE OF CONTENTS

<b>Sprockets 101</b>	<b>08 - 13</b>	<b>Bushings, Hubs, Idlers and Chain Tensioners</b>	<b>163</b>
<b>Complementary Products</b>	<b>16 - 17</b>	TAPER-LOCK® Bushings	164 - 167
<b>Stock Sprocket Products</b>		TAPER-LOCK® Weld-On Hubs	168 - 169
NO. 25: 1/4" PITCH	18 - 21	QD® Bushings	170 - 173
NO. 35: 3/8" PITCH	22 - 33	QD® Weld-On Hubs	174 - 175
NO. 41: 1/2" PITCH	34 - 41	Idler Sprockets	176 - 178
NO. 40: 1/2" PITCH	42 - 57	Chain Tensioners	179 - 180
NO. 50: 5/8" PITCH	58 - 73		
NO. 60: 3/4" PITCH	74 - 89	<b>Engineering Data</b>	<b>181</b>
NO. 80: 1" PITCH	90 - 105	Alterations	182 - 185
NO. 100: 1-1/4" PITCH	106 - 117	Sprocket Hardening	186
NO. 120: 1-1/2" PITCH	118 - 125	Sprocket Tooth Dimensions	187
NO. 140: 1-3/4" PITCH	126 - 133	Sprocket Pitch Diameter Constants	188
NO. 160: 2" PITCH	134 - 139	Sprocket Speed Ratios	189
NO. 180: 2-1/4" PITCH	140 - 141	Sprocket Diameters	190 - 192
NO. 200: 2-1/2" PITCH	142 - 143	Standard Keyway and Set Screws	193
NO. 240: 3" PITCH	144 - 145	TAPER-LOCK® Shallow Keyway Dimensions	194
NO. 2040: 1" PITCH	146 - 147	QD® Shallow Keyway Dimensions	195
NO. 2042: 1" PITCH	148 - 149	Maintenance Checklist	196
NO. 2050: 1-1/4" PITCH	150 - 151	Safety Warning	197
NO. 2052: 1-1/4" PITCH	152 - 153	Other Sprocket Considerations	198 - 199
NO. 2060: 1-1/2" PITCH	154 - 155	Terms and Conditions of Sale	200
NO. 2062: 1-1/2" PITCH	156 - 157		
NO. 2080: 2" PITCH	158 - 159		
NO. 2082: 2" PITCH	160 - 161		
Double Plus Sprockets®	162		



[www.tsubaki.ca](http://www.tsubaki.ca)

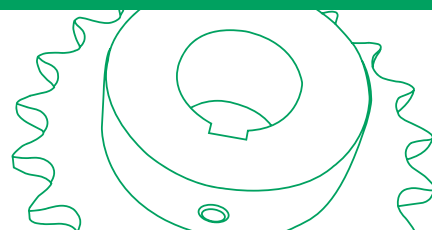

# SPROCKETS 101

The following defines terminology and provides guidance to help select the best sprocket for a given application. In the event that further assistance is required, please call Tsubaki customer service at (800) 263 -7088.

## Basic Terminology

01

### ANSI Chain Pitch:

The term “chain pitch” refers to the roller pin center to roller pin center dimension of a given chain. The pitch is always measured in 1/8" increments. Please see **Figure 1** for an illustration of how to measure chain pitch. Please see **Table 1** for referencing ANSI Standard chain pitch sizes.

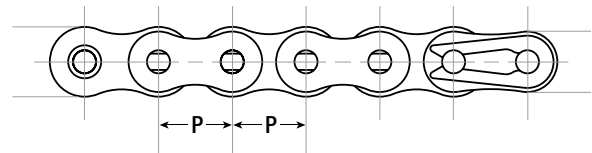

Figure 1 - Chain pitch measurement points (P)

02

### Caliper Diameter:

The term “caliper diameter” refers to the dimension measured from sprocket tooth valley to sprocket tooth valley on the opposite side (180°) of the sprocket. This dimension is used to measure the diameter of the sprocket plate (not including sprocket teeth). On sprockets that have an odd number of teeth, the measurement would be taken from the valley of one tooth to the valley as close to 180° on the opposite side of the sprocket. Please reference **Figure 2** for an illustration of how this dimension is measured.

ANSI Standard Chain Pitch Size			
Pitch #	Pitch in IN	Pitch #	Pitch in IN
25	1/4"	100	1-1/4"
35	3/8"	120	1-1/2"
40	1/2"	140	1-3/4"
41	1/2"	160	2"
50	5/8"	180	2-1/4"
60	3/4"	200	2-1/2"
80	1"	240	3"

Table 1 - ANSI Standard Chain Pitch Table

03

### Sprocket Outside Diameter:

Sprocket outside diameter is the measurement from sprocket tooth peak to sprocket tooth peak on the opposite (180°) side of the sprocket. For sprockets with an odd number of teeth, the measurement would be taken from the peak of one sprocket tooth to the peak of a tooth as close to 180° degrees as possible. Please refer to **Figure 3** for an illustration as to how this dimension is measured.

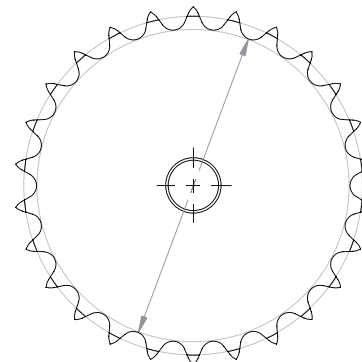

Figure 2 - Measuring caliper diameter

# SPROCKETS 101

04

**Maximum Bore Diameter:** Refers to the maximum bore size diameter a sprocket can be machined to without compromising structural integrity. This term is associated with both “B” and “C” style sprockets. Please refer to *Figure 4* for illustration.

05

**Length Thru Bore:** “LTB” Refers to the inside hub diameter and the length to which it was machined. This machined length must be long enough to accommodate the proper size keyway to withstand shear and torque stress induced by the rotating shaft. Please refer to *Figure 4* for illustration.

06

**Plain Bore:** Associated with “A,” “B” and “C” style sprockets where there is no special machining performed to accommodate keyways or set screws, only a hole to accommodate shaft diameter. Please refer to *Figure 6* for illustrations of Plain Bore sprockets.

07

**Finished Bore:** Associated with “B” and “C” style sprockets where the inside diameter of the hub is machined with a standard keyway and two set screws. Finished bore hubs can also be machined to specific requirements depending on the needs of the application. Please refer to *Figure 5* for an illustration.

08

**Sprocket Hub Style:** Tsubaki manufacturers various sprocket hub styles to meet the application requirements of our customers. Please refer to *Figure 6* for the various stock style hub configurations offered by Tsubaki.

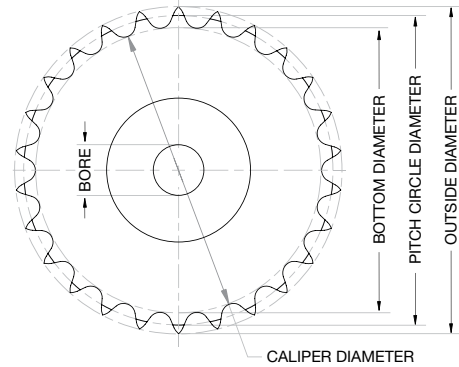

Figure 3 - Measuring sprocket outside diameter

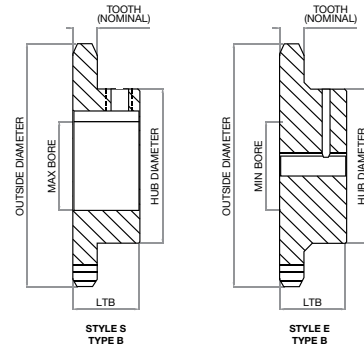

Figure 4 - Maximum bore diameter and thru bore

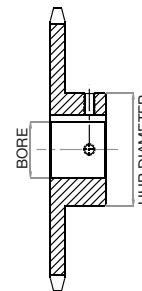

Figure 5 - Finished bore sprocket

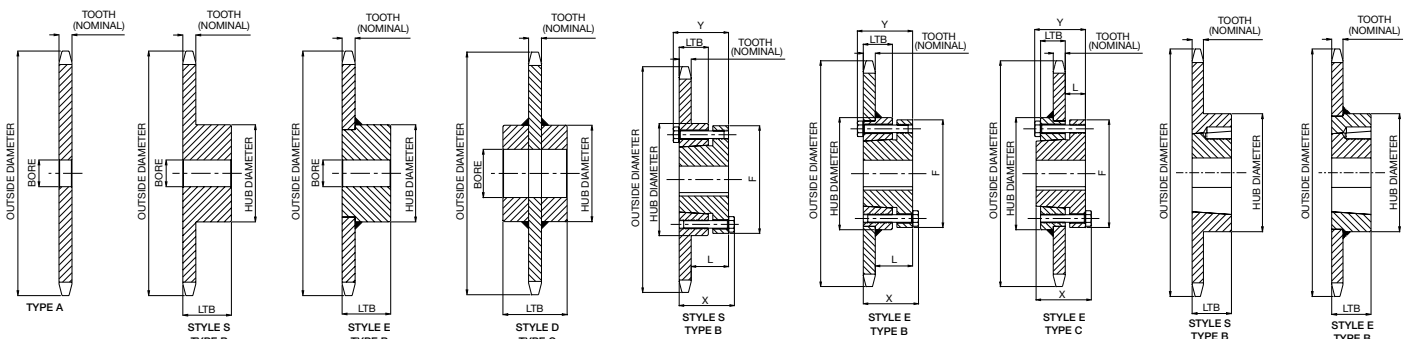

Figure 6 - Stock sprocket hub styles



# SPROCKETS 101

09

## Small and Large Roller Double Pitch Sprockets:

Used with double pitch conveyor series roller chains. These chains are available with either the standard small roller diameter (i.e.: 2040, 2050, 2060, 2080, 2100) or a larger diameter chain roller style (i.e.: 2042, 2052, 2062, 2082, 2102). Sprockets are available from stock to accommodate either style. This type of sprocket is primarily used in conveying applications where torque requirements are lower, and long service life is critical. Please refer to [Figure 7](#) for an illustration of a standard and double pitch sprocket for comparison purposes.



*Figure 7 - Small and large roller double pitch sprockets*

10

## Multiple-Strand Sprockets:

This type of sprocket is commonly used in applications where higher torque and power requirements are needed. The spacing between the rows of teeth corresponds with the center-line of chain strands. Due to the added width of chain, the “LTB” of multiple strand sprockets is correspondingly longer. This style of sprocket is available in 40 through 160 chain pitch with plain, finished or TAPER-LOCK®/QD® style hubs. Please refer to [Figure 8](#) for an illustration of a Multiple-Strand sprocket.



*Figure 8 - Multiple-Strand sprockets*

11

## DOUBLE PLUS® Sprockets:

This type of sprocket is specifically designed to work with DOUBLE PLUS® chain. This style of sprocket is used in conveyor applications where product on the conveyor is propelled at twice speed of the drive system powering the conveyor. The main benefit of incorporating DOUBLE PLUS® chain and sprockets is less noise and longer chain life. Please refer to [Figure 9](#) for an illustration of a DOUBLE PLUS® sprocket.



*Figure 9 - DOUBLE PLUS® sprockets*

# SPROCKETS 101

12

## QD® Sprockets:

This type of sprocket is used in applications where higher working loads are prevalent, and high clamp loading on the drive shaft is desirable. Sprockets with tapered bushings will fall into the QD®, Split-Taper or TAPER-LOCK® family. QD® bushings are flanged, and most commonly utilize large anchor bolts around the circumference of the flange to retain itself to the sprocket. However, this style of bushing is also available in a weld on hub configuration. One of the primary advantages the QD® bushing offers is its ease of installation and removal. It also provides superior clamp force, and aligns the sprocket 90° to the drive shaft to assure proper alignment. Please refer to [Figure 10](#) for an illustration of a QD® sprocket.



*Figure 10 - QD® sprocket*

13

## TAPER-LOCK® Sprockets:

TAPER-LOCK® bushings are similar to QD® style bushings in that they both utilize a split through the taper and flange to provide a true clamp on the shaft that is equivalent to a shrink fit. This type of bushing is retained to the sprocket with a series of set screws on the outside diameter of the bushing running parallel to the shaft, or can be welded to the sprocket itself. With TAPER-LOCK® bushings, there is no need for a set screw over the drive shaft key. TAPER-LOCK® bushings offer flexibility in that they allow multiple sized bores for a single bushing size. Please refer to [Figure 11](#) for an illustration of a TAPER-LOCK® sprocket.



*Figure 11 - TAPER-LOCK® sprocket*

14

## Steel Split Sprockets:

Split sprockets are slit through the entire diameter of the sprocket to allow ease of installation and removal. The sprocket halves are held together by bolts located on either side of the hub. This particular style is available in chain pitch sizes of 40 through 240, and bore diameters of 3/4" through 6" depending on chain pitch selected. [Figure 12](#) provides an illustration of a steel split sprocket.



*Figure 12 - Steel Split sprocket*

# SPROCKETS 101

15

## British Standard Sprockets:

This style of sprocket is similar to an ANSI style sprocket with the exception of the fact that it is designed to propel British Standard Chain. British Standard Chain has slightly different dimensions with regard to chain pitch and roller diameter. ANSI Standard chain pitch is measured in 1/8" increments (pin to pin), whereas British Standard follows a 1/16" pin to pin spacing. Please see [Figure 13](#) for an illustration of how to measure British Standard chain pitch.

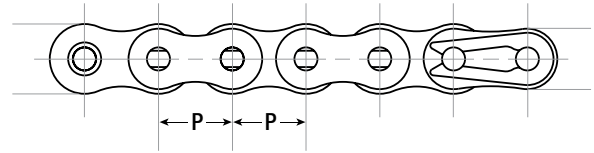

*Figure 13 - Measuring British Standard Chain*

16

## Double Single Sprockets:

This type of sprocket is commonly used in applications where two or more items are powered by a common drive shaft. The space between the sprocket plates is wider than a multi-strand sprocket, and allows two separate strands of chain to engage without contacting each other. With this type of sprocket, one strand of chain may exit in a different direction than the other. For example, one strand exiting towards the ceiling and the other running parallel to the floor. Please refer to [Figure 14](#) for an illustration of a Double Single sprocket.



*Figure 14 - Double Single Sprocket*

17

## Idler Sprockets:

This type of sprocket is used in applications where the drive chain may experience slack due to long lengths, non-adjustability of the driven shaft, or where the chain has to be guided around an obstruction. Use of Idler Sprockets prevents chain whipping and uneven distribution of load. This type of sprocket can also be used in applications where the drive chain may experience direction reversal, or in applications where the chain may experience whipping. Having idler sprockets touching the outside of the chain would be beneficial. Please refer to [Figure 15](#) for an illustration of an Idler Sprocket.



*Figure 15 - Idler Sprocket*

# SPROCKETS 101

18

## How to Order Code:

The following decodes the model number for a given Tsubaki Stock Sprocket product. The following example should be used to decipher the characteristics and features associated with a given sprocket.

A	35	B	TL	18		
Altered <sup>!!</sup>	Chain Pitch in Inches	Hub Type	TAPER-LOCK <sup>®</sup>	Number of Teeth		
A: Alteration Required	35: 3/8" Pitch	B: Hub Extension One Side	TAPER-LOCK <sup>®</sup> hub	18	22	26
				19	23	28
				20	24	30
				21	25	32

19

## Altered<sup>!!</sup>:

The term "Altered" applies to a sprocket that requires a minor modification to the standard configuration to fulfill the requirements of the application at hand. Some examples of common alterations include: rebore to a different size than standard, different set screw location than standard, drilling of holes into sprocket plate for accessory mounting, non-standard keyway size, etc. A complete list of common alterations is available in the engineering section of this catalog. It should be noted that adding the prefix "A" is used only when an alteration is required. It is not necessary for standard products and only applies when a non-standard feature is required.

20

## Fraction Legend for Hub Bore Size:

The following table should be used to define the hub bore size associated with "Finished Bore" stock sprocket product. Note that a letter designator is used to represent a fractional dimension. For example: a 1B hub bore equates to a sprocket bore of 1.125" inside diameter.

Letter Designator	Fractional Size	Decimal Size
A	1/16"	0.0625"
B	1/8"	0.1250"
C	3/16"	0.1875"
D	1/4"	0.2500"
E	5/16"	0.3125"
F	3/8"	0.3750"
G	7/16"	0.4375"
H	1/2"	0.5000"
I	9/16"	0.5625"
J	5/8"	0.6250"
K	11/16"	0.6875"
L	3/4"	0.7500"
M	13/16"	0.8125"
P	7/8"	0.8750"
R	15/16"	0.9375"



# SPROCKETS SOLUTIONS

## WHY TSUBAKI SPROCKETS ARE YOUR BEST CHOICE...

Tsubaki finished bore sprockets come with a keyway and two set screws standard.

Tsubaki stock sprockets are made from 1045 cold rolled carbon steel, and are black oxide coated for maximum corrosion resistance and durability. No powdered metal is used.

All Tsubaki stock sprockets have hardened teeth to RC 35 - 50 standard on ANSI 35 - 80 pitch. This ensures long service life with minimal wear.

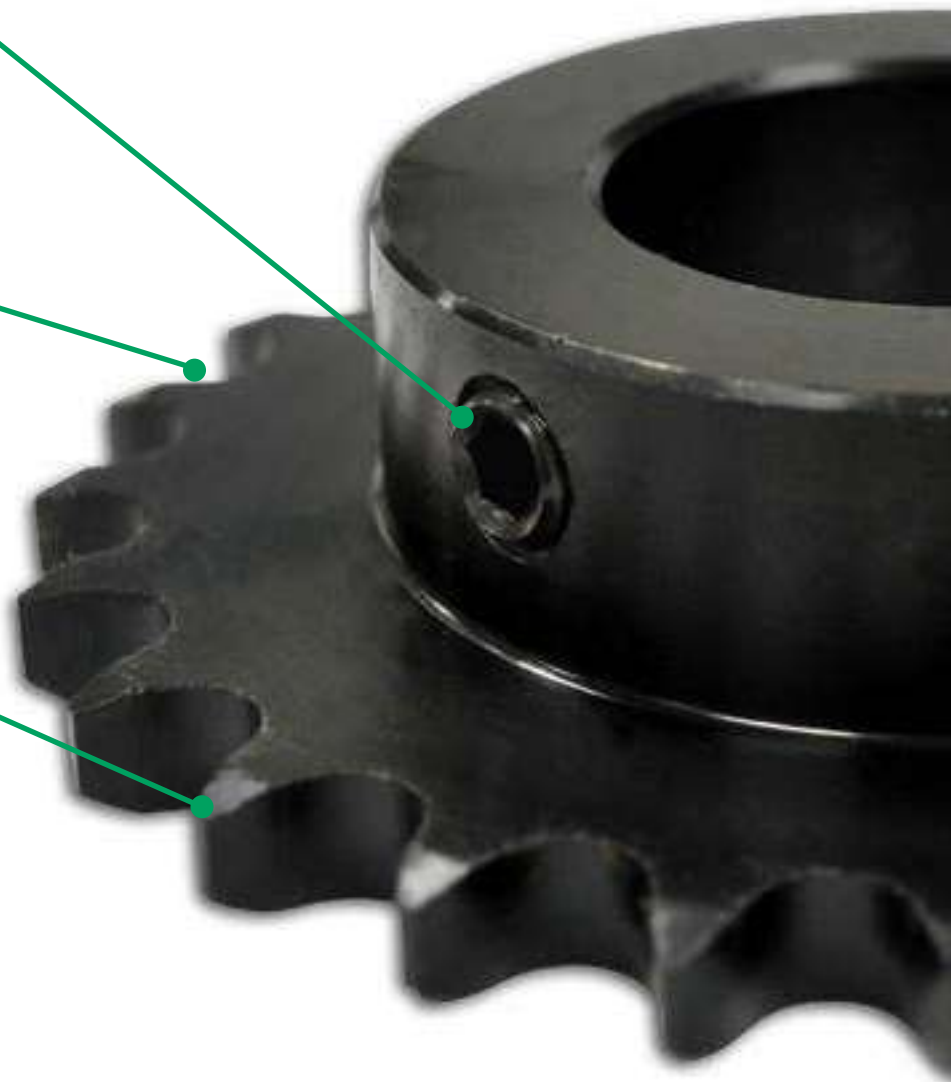

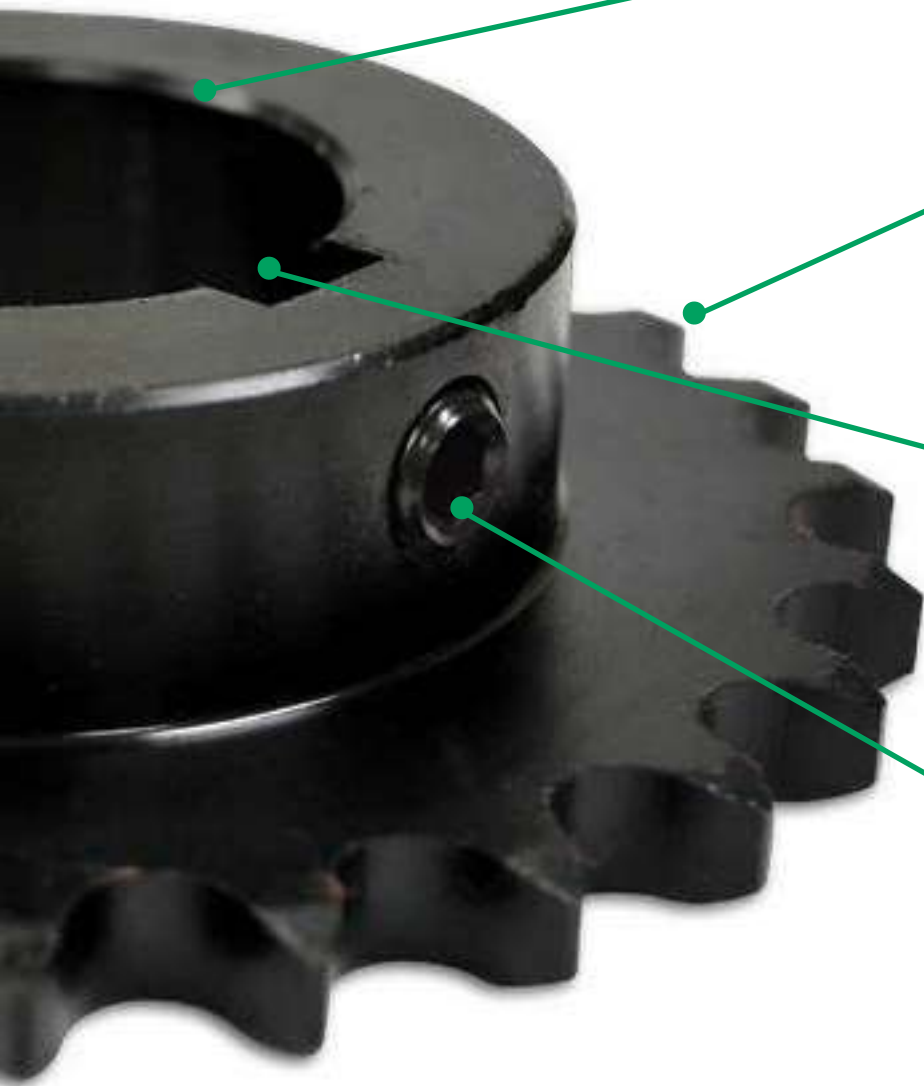

All hard edges are chamfered and de-burred for the best fit.

Tsubaki sprockets are available in ANSI standard or British Standard pitch specifications.

Tsubaki offers stock/plain bore, finished bore, and altered sprockets for rapid delivery to meet your application requirements fast!!!

Standard set screw placement directly over the keyway and at 90° to the keyway ensures the sprocket will hold position throughout its time in service.

# COMPLEMENTARY PRODUCTS

## POWER-LOCK®

Tsubaki POWER-LOCK® technology provides a keyless sprocket to drive shaft locking solution for applications that experience load reversal and high torque loading. POWER-LOCK® eliminates the need for costly machining associated with long keyways, spline bores, threaded shafts and grooves or steps to prevent premature failure. POWER-LOCK® technology offer fast installation and removal, and can be used on sprockets, gears, pulleys, timing cams, and rollers to increase shaft strength, and ensure long service life.



## TORQUE SHIELD

Tsubaki Torque Shield provides mechanical drive system protection for sophisticated applications that may experience overloading or jamming. Applications that demand consistent and predictable trip settings with quick resetting will benefit from this device. Torque Shield is easy to set and adjust with a built-in scale and indicator that have distinct torque settings for easy verification. Tsubaki offers four different series of Torque Shield products to support all of your drive system needs.



## TORQUE LIMITER

Refined by Tsubakimoto for over 40 years, the Torque Limiter is a simple and inexpensive mechanical device that limits damage to equipment when an unexpected increase in torque occurs because of a jam or overload situation. Easy to install, the Torque Limiter attaches to a shaft and holds the sprocket, gear, or sheave. A frictional system, the Torque Limiter reacts instantly when there is a jam by slipping and absorbing the brunt of the force, thus preventing the increase in power from damaging your equipment. Let Tsubaki's family of Torque Limiters provide an economical solution for protecting your drive system.



# COMPLEMENTARY PRODUCTS

## LINEAR SHIELD

Designed for pushing/pulling applications, Tsubaki's Linear Shield provides system protection for equipment used in straight line applications. Machine tool, press applications, pick and place, and other linear system operations are protected from overloading by a simple ball and groove design. Compact design, ease of installation, and quick resetting makes this device ideal for limiting downtime and preserving critical equipment operation.



## SHOCK RELAY®

Pioneered by Tsubaki, the Shock Relay® protects your equipment against unexpected shock loads and overloads before system damage occurs. The Shock Relay® adapts to virtually any type of equipment that's driven by an electric motor. The purpose of the Shock Relay® is to protect the mechanical parts of the equipment by monitoring drive motor current, shutting down the equipment when the loads exceed the user set limits. Unlike mechanical protection devices, there is no physical re-setting required. The Tsubaki Shock Relay® simply resets at the press of a button. Let Tsubaki's family of Shock Relays keep your production up and running.





# HOW TO ORDER

TSUBAKI STOCK SPROCKETS



## No. 25 1/4" Pitch: PLAIN BORE

Chain Data	
Size	25
Pitch	1/4"
Inside Width	1/8"
Roller Diameter	0.130"
Nominal Tooth Width:	0.110"

How to Order Code: Example Model # for 25 Pitch Plain Bore Sprockets

<b>A</b>	<b>25</b>	<b>A</b>	<b>36</b>			
Altered <sup>‡</sup>	Chain Pitch in Inches	Hub Type	Number of Teeth			
A: Alteration Required	25: 1/4" Pitch	A: No Hub Extension	15	21	28	45
			16	22	30	48
			17	23	32	54
			18	24	35	60
			19	25	36	72
			20	26	40	
		B: Hub Extension One Side	9	17	25	45
			10	18	26	48
			11	19	28	54
			12	20	30	60
			13	21	32	72
			14	22	35	
			15	23	36	
			16	24	40	

<sup>‡</sup>Alteration field only to be denoted if a deviation from standard is required. Please reference Alterations in engineering section, page 182.

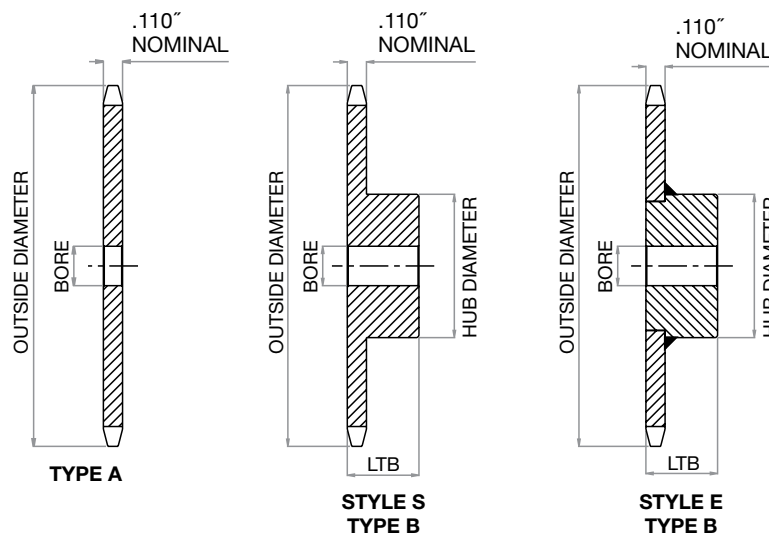

# No. 25

## PLAIN BORE SPROCKET DIMENSIONS

Tsubaki Stock Sprockets

All dimensions in inches unless noted.

No. 25 Plain Bore Sprocket Diameters				Type "A" Plain Bore		Type "B" Plain Bore					
No. Teeth	Outside Diameter	Pitch Diameter	Caliper Diameter	Plain Bore	Wt. Lbs.	Plain Bore	MAX Bore*	Hub Dia.	LTB	Style	Wt. Lbs.
9	0.837	0.731	0.591	NS	NS	0.250	0.250	0.438	0.500	S	0.03
10	0.919	0.809	0.679	NS	NS	0.250	0.250	0.500	0.500	S	0.03
11	1.002	0.870	0.748	NS	NS	0.250	0.313	0.563	0.500	S	0.04
12	1.083	0.996	0.836	NS	NS	0.250	0.375	0.625	0.500	S	0.06
13	1.167	1.045	0.907	NS	NS	0.250	0.438	0.781	0.500	S	0.07
14	1.246	1.124	0.994	NS	NS	0.250	0.563	0.813	0.500	S	0.08
15	1.326	1.203	1.066	0.250	0.040	0.250	0.563	0.891	0.500	S	0.10
16	1.407	1.282	1.152	0.250	0.040	0.250	0.563	0.969	0.500	S	0.12
17	1.487	1.361	1.225	0.250	0.040	0.250	0.625	1.031	0.500	S	0.14
18	1.568	1.440	1.310	0.250	0.040	0.250	0.750	1.125	0.500	S	0.16
19	1.648	1.519	1.383	0.250	0.040	0.250	0.813	1.219	0.500	S	0.19
20	1.729	1.598	1.468	0.250	0.040	0.250	0.875	1.281	0.625	S	0.25
21	1.809	1.678	1.543	0.375	0.040	0.250	0.875	1.375	0.625	S	0.28
22	1.889	1.757	1.627	0.375	0.060	0.250	0.938	1.438	0.625	S	0.31
23	1.969	1.836	1.702	0.375	0.060	0.250	1.000	1.500	0.625	S	0.32
24	2.049	1.915	1.785	0.375	0.080	0.375	1.000	1.500	0.625	S	0.33
25	2.129	1.995	1.861	0.375	0.080	0.375	1.000	1.500	0.625	S	0.34
26	2.209	2.074	1.944	0.375	0.090	0.375	1.000	1.500	0.625	S	0.35
28	2.369	2.233	2.103	0.375	0.100	0.375	1.000	1.500	0.625	S	0.36
30	2.529	2.392	2.262	0.375	0.120	0.375	1.000	1.500	0.625	S	0.38
32	2.688	2.551	2.421	0.375	0.140	0.375	1.000	1.500	0.625	S	0.40
35	2.928	2.789	2.656	0.375	0.160	0.375	1.000	1.500	0.625	S	0.46
36	3.008	2.889	2.739	0.375	0.180	0.375	1.000	1.500	0.750	S	0.50
40	3.327	3.187	3.057	0.500	0.200	0.500	1.375	2.000	0.750	E	0.53
45	3.725	3.584	3.452	0.500	0.250	0.500	1.375	2.000	0.750	E	0.56
48	3.964	3.823	3.693	0.500	0.320	0.500	1.375	2.000	0.750	E	0.56
54	4.442	4.300	4.170	0.500	0.380	0.500	1.375	2.000	0.750	E	1.00
60	4.920	4.777	4.647	0.500	0.540	0.500	1.375	2.000	0.750	E	1.10
72	5.876	5.732	5.602	0.500	0.740	0.500	1.375	2.000	0.750	E	1.30

\* Dimensions shown allow for standard keyway with set screw at 90 degrees  
NS = Non Stock

# HOW TO ORDER

TSUBAKI STOCK SPROCKETS



## No. 25 1/4" Pitch: STAINLESS STEEL PLAIN BORE

Chain Data	
Size	25SS
Pitch	1/4"
Inside Width	1/8"
Roller Diameter	0.130"
Nominal Tooth Width:	0.110"

How to Order Code: Example Model # for 25 Pitch Plain Bore Stainless Steel Sprockets

<b>A</b>	<b>25</b>	<b>B</b>	<b>14</b>	<b>SS</b>																								
Altered <sup>#</sup>	Chain Pitch in Inches	Hub Type	Number of Teeth	Material																								
A: Alteration Required	25: 1/4" Pitch	B: Hub Extension One Side	<table border="1"> <tr> <td style="text-align: center;">9</td> <td style="text-align: center;">15</td> <td style="text-align: center;">21</td> <td style="text-align: center;">28</td> </tr> <tr> <td style="text-align: center;">10</td> <td style="text-align: center;">16</td> <td style="text-align: center;">22</td> <td style="text-align: center;">30</td> </tr> <tr> <td style="text-align: center;">11</td> <td style="text-align: center;">17</td> <td style="text-align: center;">23</td> <td style="text-align: center;">36</td> </tr> <tr> <td style="text-align: center;">12</td> <td style="text-align: center;">18</td> <td style="text-align: center;">24</td> <td style="text-align: center;">40</td> </tr> <tr> <td style="text-align: center;">13</td> <td style="text-align: center;">19</td> <td style="text-align: center;">25</td> <td style="text-align: center;">45</td> </tr> <tr> <td style="text-align: center;">14</td> <td style="text-align: center;">20</td> <td style="text-align: center;">26</td> <td style="text-align: center;">60</td> </tr> </table>	9	15	21	28	10	16	22	30	11	17	23	36	12	18	24	40	13	19	25	45	14	20	26	60	SS: 304 Stainless Steel Construction
9	15	21	28																									
10	16	22	30																									
11	17	23	36																									
12	18	24	40																									
13	19	25	45																									
14	20	26	60																									

<sup>#</sup> Alteration field only to be denoted if a deviation from standard is required. Please reference Alterations in engineering section, page 182.

# No. 25

## STAINLESS STEEL SPROCKET DIMENSIONS

Tsubaki Stock Sprockets

All dimensions in inches unless noted.

No. 25 Stainless Steel Sprocket Diameters				Type "B" Plain Bore				
No. Teeth	Outside Diameter	Pitch Diameter	Caliper Diameter	Plain Bore	MAX Bore*	Hub Dia.	LTB	Wt. Lbs.
9	0.837	0.731	0.591	0.250	0.250	0.438	0.500	0.03
10	0.919	0.809	0.679	0.250	0.250	0.500	0.500	0.03
11	1.002	0.870	0.748	0.250	0.313	0.563	0.500	0.03
12	1.083	0.966	0.836	0.250	0.375	0.625	0.500	0.06
13	1.167	1.045	0.907	0.250	0.438	0.719	0.500	0.07
14	1.246	1.124	0.994	0.250	0.563	0.813	0.500	0.08
15	1.326	1.203	1.066	0.250	0.563	0.891	0.500	0.10
16	1.407	1.282	1.152	0.250	0.563	0.969	0.500	0.12
17	1.487	1.361	1.225	0.250	0.625	1.031	0.500	0.14
18	1.568	1.440	1.310	0.250	0.750	1.125	0.500	0.16
19	1.648	1.519	1.383	0.250	0.813	1.219	0.500	0.19
20	1.729	1.598	1.468	0.250	0.875	1.281	0.625	0.25
21	1.809	1.678	1.543	0.250	0.875	1.375	0.625	0.28
22	1.889	1.757	1.627	0.250	0.938	1.438	0.625	0.31
23	1.969	1.836	1.702	0.250	1.000	1.500	0.625	0.32
24	2.049	1.915	1.785	0.375	1.000	1.500	0.625	0.33
25	2.129	1.995	1.861	0.375	1.000	1.500	0.625	0.34
26	2.209	2.074	1.944	0.375	1.000	1.500	0.625	0.35
28	2.369	2.233	2.103	0.375	1.000	1.500	0.625	0.36
30	2.529	2.392	2.262	0.375	1.000	1.500	0.625	0.38
36	3.008	2.869	2.739	0.375	1.000	1.500	0.750	0.50
40	3.327	3.187	3.057	0.500	1.375	2.000	0.750	0.53
45	3.725	3.584	3.452	0.500	1.375	2.000	0.750	0.56
60	4.920	4.777	4.647	0.500	1.375	2.000	0.750	1.10

\* Dimensions shown allow for standard keyway with set screw at 90 degrees

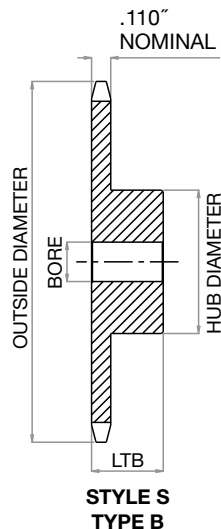

# HOW TO ORDER

TSUBAKI STOCK SPROCKETS



## No. 35 3/8" Pitch: PLAIN BORE

Chain Data	
Size	35
Pitch	3/8"
Inside Width	3/16"
Roller Diameter	0.200"
Nominal Tooth Width:	0.168"

How to Order Code: Example Model # for 35 Pitch Plain Bore Carbon Steel Sprockets

<b>A</b>	<b>35</b>	<b>A</b>	<b>24</b>			
Altered <sup>1)</sup>	Chain Pitch in Inches	Hub Type	Number of Teeth			
A: Alteration Required	35: 3/8" Pitch	A: No Hub Extension	15	24	40	84
			16	25	42	96
			17	26	45	112
			18	27	48	
			19	28	54	
			20	30	60	
			21	32	70	
			22	35	72	
			23	36	80	
		B: Hub Extension One Side	8	18	28	60
			9	19	30	70
			10	20	32	72
			11	21	35	80
			12	22	36	84
			13	23	40	96
			14	24	42	112
			15	25	45	
16	26	48				
17	27	54				

<sup>1)</sup> Alteration field only to be denoted if a deviation from standard is required. Please reference Alterations in engineering section, page 182.

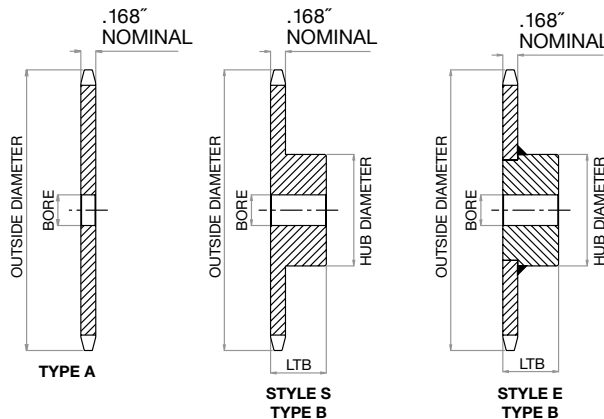

# No. 35

## PLAIN BORE SPROCKET DIMENSIONS

Tsubaki Stock Sprockets

All dimensions in inches unless noted.

No. 35 Plain Bore Sprocket Dia.				Type "A" Plain Bore		Type "B" Plain Bore					
No. Teeth	Outside Dia.	Pitch Dia.	Caliper Dia.	Plain Bore	Wt. Lbs.	Plain Bore	MAX Bore*	Hub Dia.	LTB	Style	Wt. Lbs.
8	1.130	0.980	0.780	NS	NS	0.375	0.375	0.750 "	0.750	S	0.07
9	1.260	1.097	0.880	NS	NS	0.375	0.375	0.844 "	0.750	S	0.09
10	1.380	1.214	1.014	NS	NS	0.375	0.563	0.969 "	0.750	S	0.14
11	1.500	1.331	1.117	NS	NS	0.375	0.563	1.063 "	0.750	S	0.17
12	1.630	1.449	1.249	NS	NS	0.500	0.563	1.219 "	0.750	S	0.20
13	1.750	1.567	1.356	NS	NS	0.500	0.688	1.250 "	0.750	S	0.23
14	1.870	1.685	1.485	NS	NS	0.500	0.875	1.250	0.750	S	0.25
15	1.990	1.804	1.594	0.500	0.110	0.500	0.875	1.344	0.750	S	0.29
16	2.110	1.922	1.722	0.500	0.120	0.500	0.938	1.469	0.750	S	0.35
17	2.230	2.041	1.832	0.500	0.140	0.500	1.063	1.594	0.750	S	0.42
18	2.350	2.160	1.960	0.500	0.160	0.500	1.188	1.719	0.750	S	0.48
19	2.470	2.279	2.071	0.500	0.170	0.500	1.250	1.844	0.750	S	0.54
20	2.590	2.397	2.197	0.500	0.190	0.500	1.313	1.938	0.750	S	0.59
21	2.710	2.516	2.309	0.500	0.210	0.500	1.375	2.000	0.875	S	0.80
22	2.830	2.635	2.435	0.500	0.240	0.500	1.375	2.000	0.875	S	0.80
23	2.950	2.754	2.548	0.500	0.260	0.500	1.375	2.000	0.875	S	0.82
24	3.070	2.873	2.673	0.500	0.280	0.500	1.375	2.000	0.875	S	0.88
25	3.190	2.992	2.786	0.500	0.310	0.500	1.375	2.000	0.875	S	0.88
26	3.310	3.111	2.911	0.500	0.330	0.500	1.375	2.000	0.875	E	0.90
27	3.430	3.230	3.025	0.500	0.360	0.500	1.375	2.000	0.875	E	0.94
28	3.550	3.349	3.149	0.500	0.380	0.500	1.375	2.000	0.875	E	0.94
30	3.790	3.588	3.388	0.500	0.440	0.500	1.375	2.000	0.875	E	1.02
32	4.030	3.826	3.626	0.625	0.500	0.500	1.375	2.000	0.875	E	1.24
35	4.390	4.184	3.979	0.625	0.610	0.625	1.500	2.250	0.875	E	1.50
36	4.510	4.303	4.103	0.625	0.640	0.625	1.500	2.250	0.875	E	1.56
40	4.990	4.780	4.580	0.594	0.790	0.625	1.500	2.250	1.000	E	1.62
42	5.230	5.018	4.818	0.594	0.900	0.625	1.500	2.250	1.000	E	1.68
45	5.590	5.376	5.173	0.594	1.000	0.625	1.500	2.250	1.000	E	1.78
48	5.950	5.734	5.534	0.594	1.100	0.625	1.500	2.250	1.000	E	1.88
54	6.660	6.449	6.249	0.594	1.400	0.625	1.500	2.250	1.000	E	2.20
60	7.380	7.165	6.965	0.594	1.800	0.750	1.500	2.250	1.000	E	2.48
70	8.580	8.358	8.158	0.719	2.400	0.750	1.500	2.250	1.000	E	3.12
72	8.810	8.597	8.397	0.719	2.600	0.750	1.500	2.250	1.000	E	3.42
80	9.770	9.552	9.352	0.719	3.200	0.750	1.500	2.250	1.000	E	3.82
84	10.250	10.029	9.829	0.719	3.500	0.750	1.500	2.250	1.000	E	4.24
96	11.680	11.461	11.261	0.719	4.600	0.750	1.500	2.250	1.000	E	5.16
112	13.590	13.371	13.171	0.719	6.300	0.750	1.500	2.250	1.000	E	6.70

\* Dimensions shown allow for standard keyway with set screw at 90 degrees

" Has recessed groove in hub for chain clearance

NS = Non Stock

# HOW TO ORDER

TSUBAKI STOCK SPROCKETS



## No. 35 3/8" Pitch: STAINLESS STEEL PLAIN BORE

Chain Data	
Size	35SS
Pitch	3/8"
Inside Width	3/16"
Roller Diameter	0.200"
Nominal Tooth Width:	0.168"

How to Order Code: Example Model # for 35 Pitch Plain Bore Stainless Steel Sprockets

<b>A</b>	<b>35</b>	<b>B</b>	<b>17</b>	<b>SS</b>																								
Altered <sup>#</sup>	Chain Pitch in Inches	Hub Type	Number of Teeth	Material																								
A: Alteration Required	35: 3/8" Pitch	B: Hub Extension One Side	<table border="1"> <tr> <td style="text-align: center;">9</td> <td style="text-align: center;">15</td> <td style="text-align: center;">21</td> <td style="text-align: center;">28</td> </tr> <tr> <td style="text-align: center;">10</td> <td style="text-align: center;">16</td> <td style="text-align: center;">22</td> <td style="text-align: center;">30</td> </tr> <tr> <td style="text-align: center;">11</td> <td style="text-align: center;">17</td> <td style="text-align: center;">23</td> <td style="text-align: center;">35</td> </tr> <tr> <td style="text-align: center;">12</td> <td style="text-align: center;">18</td> <td style="text-align: center;">24</td> <td style="text-align: center;">40</td> </tr> <tr> <td style="text-align: center;">13</td> <td style="text-align: center;">19</td> <td style="text-align: center;">25</td> <td style="text-align: center;">45</td> </tr> <tr> <td style="text-align: center;">14</td> <td style="text-align: center;">20</td> <td style="text-align: center;">26</td> <td style="text-align: center;">60</td> </tr> </table>	9	15	21	28	10	16	22	30	11	17	23	35	12	18	24	40	13	19	25	45	14	20	26	60	SS: 304 Stainless Steel Construction
9	15	21	28																									
10	16	22	30																									
11	17	23	35																									
12	18	24	40																									
13	19	25	45																									
14	20	26	60																									

<sup>#</sup> Alteration field only to be denoted if a deviation from standard is required. Please reference Alterations in engineering section, page 182.

# No. 35

## STAINLESS STEEL SPROCKET DIMENSIONS

Tsubaki Stock Sprockets

All dimensions in inches unless noted.

No. 35 Stainless Steel Sprocket Diameters				Type "B" Plain Bore					
No. Teeth	Outside Diameter	Pitch Diameter	Caliper Diameter	Plain Bore	MAX Bore*	Hub Dia.	LTB	Hub Style	Wt. Lbs.
9	1.260	1.097	0.880	0.375	0.375	0.844 "	0.750	S	0.10
10	1.380	1.214	1.014	0.375	0.563	0.969 "	0.750	S	0.15
11	1.500	1.331	1.117	0.375	0.563	1.063 "	0.750	S	0.20
12	1.630	1.449	1.249	0.500	0.563	1.219 "	0.750	S	0.22
13	1.750	1.567	1.356	0.500	0.688	1.250 "	0.750	S	0.25
14	1.870	1.685	1.485	0.500	0.875	1.250	0.750	S	0.26
15	1.990	1.804	1.594	0.500	0.875	1.344	0.750	S	0.30
16	2.110	1.922	1.722	0.500	0.938	1.469	0.750	S	0.40
17	2.230	2.041	1.832	0.500	1.063	1.594	0.750	S	0.43
18	2.350	2.160	1.960	0.500	1.188	1.719	0.750	S	0.50
19	2.470	2.279	2.071	0.500	1.250	1.844	0.750	S	0.56
20	2.590	2.397	2.197	0.500	1.313	1.938	0.750	S	0.68
21	2.710	2.516	2.309	0.500	1.375	2.000	0.875	S	0.80
22	2.830	2.635	2.435	0.500	1.375	2.000	0.875	S	0.82
23	2.950	2.754	2.548	0.500	1.375	2.000	0.875	S	0.87
24	3.070	2.873	2.673	0.500	1.375	2.000	0.875	S	0.89
25	3.190	2.992	2.786	0.500	1.375	2.000	0.875	S	0.91
26	3.310	3.111	2.911	0.500	1.375	2.000	0.875	S	0.93
28	3.550	3.349	3.149	0.500	1.375	2.000	0.875	E	1.00
30	3.790	3.588	3.388	0.500	1.375	2.000	0.875	E	1.06
35	4.390	4.184	3.979	0.625	1.500	2.250	0.875	E	1.56
40	4.990	4.780	4.580	0.625	1.500	2.250	1.000	E	1.70
45	5.590	5.376	5.173	0.625	1.500	2.250	1.000	E	2.18
60	7.380	7.165	6.965	0.750	1.500	2.250	1.000	E	3.00

\* Dimensions shown allow for standard keyway with set screw at 90 degrees

" Has recessed groove in hub for chain clearance

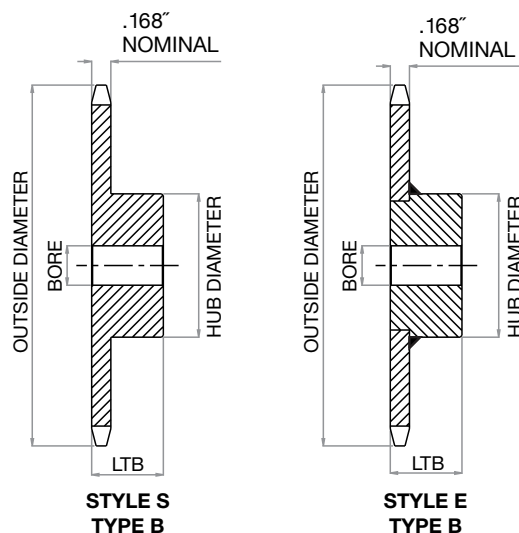



# HOW TO ORDER

TSUBAKI STOCK SPROCKETS



## No. 35 3/8" Pitch: FINISHED BORE

Chain Data	
Size	35
Pitch	3/8"
Inside Width	3/16"
Roller Diameter	0.200"
Nominal Tooth Width:	0.168"

How to Order Code: Example Model # for 35 Pitch Finished Bore Carbon Steel Sprockets

<b>35</b>	<b>B</b>	<b>24</b>	<b>F -</b>	<b>1B</b>
-----------	----------	-----------	------------	-----------

Chain Pitch in Inches	Hub Type	Number of Teeth				Finished Bore	Hub Bore**		
35: 3/8" Pitch	B: Hub Extension One Side	9	18	27	48	F: Hub Extension Machined with keyway and two set screws	F	3/8"	(0.375")
		10	19	28	54		H	1/2"	(0.500")
		11	20	30	60		J	5/8"	(0.625")
		12	21	32	70		L	3/4"	(0.750")
		13	22	35	72		P	7/8"	(0.875")
		14	23	36	80		1	1"	(1.000")
		15	24	40	84		1B	1-1/8"	(1.125")
		16	25	42	96		1C	1-3/16"	(1.188")
		17	26	45	112		1D	1-1/4"	(1.250")

\*\* Hub bore size should be selected from dimensional table on the following page. Bore sizes that are not listed for a given number of sprocket teeth may be available per request as Altered.

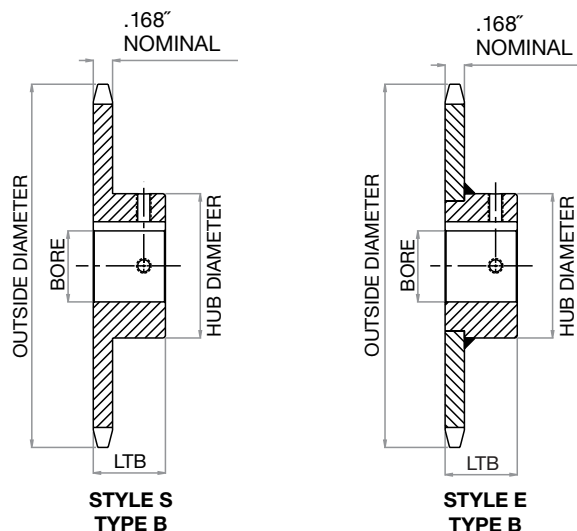

# No. 35

## FINISHED BORE SPROCKET DIMENSIONS

Tsubaki Stock Sprockets

All dimensions in inches unless noted.

No. 35 Finished Bore Sprocket Dia.				Type "F" Bored to Shaft Size (includes standard keyway and two set screws)**								
No. Teeth	Outside Dia.	Pitch Dia.	Caliper Dia.	.375"***	.500"***	.625"	.750"	.875"	1.000"	1.125"	1.1875"	1.250"
9	1.260	1.097	0.880	•								
10	1.380	1.214	1.014	•	•	•■						
11	1.500	1.331	1.117	•	•	•■	•■					
12	1.630	1.449	1.249		•	•	•■					
13	1.750	1.567	1.356		•	•	•					
14	1.870	1.685	1.485		•	•	•					
15	1.990	1.804	1.594		•	•	•	•	•■			
16	2.110	1.922	1.722		•	•	•	•	•■			
17	2.230	2.041	1.832		•	•	•	•	•			
18	2.350	2.160	1.960		•	•	•	•	•			
19	2.470	2.278	2.071		•	•	•		•			
20	2.590	2.397	2.197		•	•	•		•			
21	2.710	2.516	2.309		•	•	•		•			
22	2.830	2.635	2.435		•	•	•		•			
23	2.950	2.754	2.548		•	•	•		•			
24	3.070	2.873	2.673		•	•	•		•			
25	3.190	2.992	2.786		•	•	•		•			
26	3.310	3.111	2.911			•	•	•	•	•	•	•
27	3.430	3.230	3.025			•	•	•	•	•	•	•
28	3.550	3.349	3.149			•	•	•	•	•	•	•
30	3.790	3.588	3.388			•	•	•	•	•	•	•
32	4.030	3.826	3.626			•	•	•	•	•	•	•
35	4.390	4.184	3.979			•	•	•	•	•	•	•
36	4.510	4.303	4.103			•	•	•	•	•	•	•
40	4.990	4.780	4.580			•	•	•	•	•	•	•
42	5.230	5.018	4.818			•	•	•	•	•	•	•
45	5.590	5.376	5.173			•	•	•	•	•	•	•
48	5.950	5.734	5.534			•	•	•	•	•	•	•
54	6.660	6.449	6.249			•	•	•	•	•	•	•
60	7.380	7.165	6.965				•	•	•	•	•	•
70	8.580	8.358	8.158				•	•	•	•	•	•
72	8.810	8.597	8.397				•	•	•	•	•	•
80	9.770	9.552	9.352				•	•	•	•	•	•
84	10.250	10.029	9.829				•	•	•	•	•	•
96	11.680	11.461	11.261				•	•	•	•	•	•
112	13.590	13.371	13.171				•	•	•	•	•	•

• Denotes stocking item

\*\* Furnished without keyway

■ Indicates set screw at 90 degrees and 180 degrees from keyway

# HOW TO ORDER

TSUBAKI STOCK SPROCKETS



## No. 35 3/8" Pitch: MULTI-STRAND

Chain Data	
Size	35 - 2
Pitch	3/8"
Inside Width	3/16"
Roller Diameter	0.200"
Nominal Tooth Width:	0.162"

How to Order Code: Example Model # for 35 Pitch Double Strand Carbon Steel Sprockets

<b>A</b>	<b>D</b>	<b>35</b>	<b>B</b>	<b>18</b>			
Altered <sup>‡</sup>	Multi	Chain Pitch in Inches	Hub Type	Number of Teeth			
A: Alteration Required	D: Double Strand	35: 3/8" Pitch	B: Hub Extension One Side	13	19	25	60
				14	20	26	72
				15	21	30	84
				16	22	36	96
				17	23	42	
				18	24	48	

<sup>‡</sup> Alteration field only to be denoted if a deviation from standard is required. Please reference Alterations in engineering section, page 182.

# No. 35

## MULTI-STRAND SPROCKET DIMENSIONS

Tsubaki Stock Sprockets

All dimensions in inches unless noted.

No. 35 Multi-Strand Sprocket Diameters			Dimensional Data				
No. Teeth	Outside Dia.	Plain Bore	Hub Diameter	LTB	MAX Bore*	Style	Weight Lbs.
13	1.750	0.500	1.109	1.250	0.688	S	0.36
14	1.870	0.500	1.250	1.250	0.875	S	0.44
15	1.990	0.500	1.406	1.250	0.938	S	0.56
16	2.110	0.500	1.469	1.250	0.938	S	0.64
17	2.230	0.500	1.594	1.250	1.063	S	0.74
18	2.350	0.500	1.719	1.250	1.188	S	0.84
19	2.470	0.500	1.875	1.250	1.313	S	0.96
20	2.590	0.750	1.938	1.375	1.313	S	1.08
21	2.710	0.750	2.063	1.375	1.375	S	1.24
22	2.883	0.750	2.188	1.375	1.438	S	1.42
23	2.954	0.750	2.250	1.375	1.500	S	1.54
24	3.074	0.750	2.250	1.375	1.500	S	1.62
25	3.194	0.750	2.250	1.375	1.500	S	1.66
26	3.314	0.750	2.500	1.375	1.750	S	1.98
30	3.793	0.750	2.500	1.375	1.750	S	2.34
36	4.510	0.750	2.500	1.375	1.750	S	3.00
42	5.230	0.750	2.500	1.375	1.750	S	3.80
48	5.950	0.750	2.500	1.375	1.750	S	4.66
60	8.810	0.750	2.500	1.375	1.750	S	6.84
72	10.250	0.750	3.500	1.500	2.375	S	11.04
84	11.560	0.750	3.500	1.500	2.375	S	14.98
96	11.560	1.000	3.500	1.500	2.375	S	17.42

\* Dimensions shown allow for standard keyway with set screw at 90 degrees

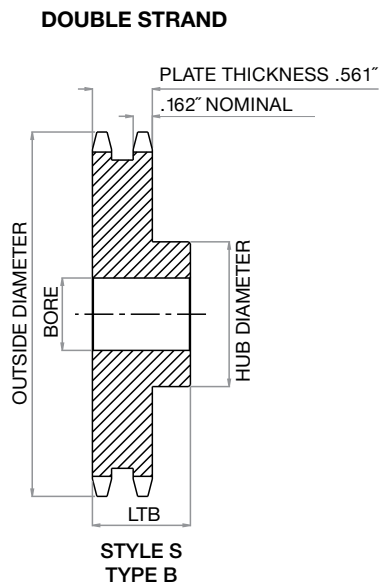

# HOW TO ORDER

TSUBAKI STOCK SPROCKETS



## No. 35 3/8" Pitch: TAPER-LOCK®

Chain Data	
Size	35
Pitch	3/8"
Inside Width	3/16"
Roller Diameter	0.200"
Nominal Tooth Width:	0.168"

How to Order Code: Example Model # for 35 Pitch TAPER-LOCK® Carbon Steel Sprockets

<b>A</b>	<b>35</b>	<b>B</b>	<b>TL</b>	<b>18</b>				
Altered <sup>¶</sup>	Chain Pitch in Inches	Hub Type	TAPER-LOCK®	Number of Teeth				
A: Alteration Required	35: 3/8" Pitch	B: Hub Extension One Side	TAPER-LOCK® hub with set screws	18	21	24	26	30
				19	22	25	28	32
				20	23			

<sup>¶</sup>Alteration field only to be denoted if a deviation from standard is required. Please reference Alterations in engineering section, page 182.

TAPER-LOCK® bushing is not included with the sprocket. They are to be ordered separately. Please refer to the table below for general guidelines. Specific details are found in the Bushing Section of this catalog beginning on page 164.

TAPER-LOCK® Bushings	
Bushing #	Bore Range
1008	0.500 - 1.000"
1210	0.500 - 1.250"
1610	0.500 - 1.688"

All dimensions in inches unless noted.

No. 35 TAPER-LOCK® Sprockets Dia.			Dimensional Data			
No. Teeth	Outside Diameter	Bushing #	MAX Bore*	LTB	Hub Diameter	Weight Lbs.
18	2.352	1008	1.000	0.875	1.875 **	0.40
19	2.472	1008	1.000	0.875	1.813	0.50
20	2.593	1008	1.000	0.875	1.938	0.60
21	2.713	1008	1.000	0.875	2.063	0.70
22	2.883	1210	1.250	1.000	2.375 **	0.80
23	2.954	1210	1.250	1.000	2.438	0.90
24	3.074	1210	1.250	1.000	2.438	0.90
25	3.194	1210	1.250	1.000	2.438	1.20
26	3.314	1610	1.688	1.000	2.875 **	1.10
28	3.553	1610	1.688	1.000	2.875	1.20
30	3.793	1610	1.688	1.000	3.125	1.20
32	4.032	1610	1.688	1.000	3.250	1.30

\* Please reference TAPER-LOCK® bushing dimension table on page 165 for specific information on MAX Bore and keyway data.

\*\* Has recessed groove in hub for chain clearance

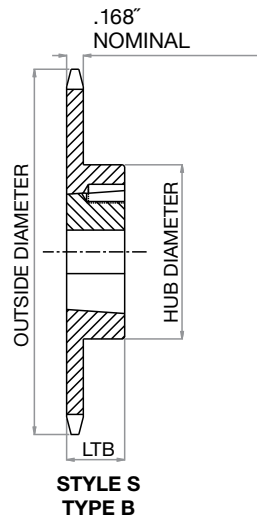

# HOW TO ORDER

TSUBAKI STOCK SPROCKETS



No.  
**35** 3/8" Pitch: QD®

Chain Data	
Size	35
Pitch	3/8"
Inside Width	3/16"
Roller Diameter	0.200"
Nominal Tooth Width:	0.168"

How to Order Code: Example Model # for 35 Pitch QD® Carbon Steel Sprockets

<b>A</b>	<b>35</b>	<b>JA</b>	<b>24</b>
----------	-----------	-----------	-----------

Altered <sup>¶</sup>	Chain Pitch in Inches	QD® Hub Type	Number of Teeth				
A: Alteration Required	35: 3/8" Pitch	JA: QD® Hub 19 - 30 tooth sprocket	19	21	25	27	30
			20	24	26	28	30
		SH: QD® Hub 40 - 84 tooth sprocket	40	45	54	70	80
			42	48	60	72	84

<sup>¶</sup>Alteration field only to be denoted if a deviation from standard is required. Please reference Alterations in engineering section, page 182.

QD® bushing is not included with the sprocket. They are to be ordered separately. Please refer to the table below for general guidelines. Specific details are found in the Bushing Section of this catalog beginning on page 170.

QD® Bushings	
Bushing #	Bore Range
JA	0.500 - 1.250"
SH	0.500 - 1.688"

All dimensions in inches unless noted.

No. 35 QD® Sprockets Dia.			Dimensional Data							
No. Teeth	Outside Diameter	Bushing #	MAX Bore*	Hub Diameter	LTB	X	Y	L	F	Weight Lbs.
19	2.472	JA	1.250	2.063	0.625	1.000	1.125	0.828	2.063	0.28
20	2.593	JA	1.250	2.063	0.625	1.125	1.125	0.828	2.063	0.32
21	2.713	JA	1.250	2.063	0.625	1.125	1.125	0.828	2.063	0.33
24	3.074	JA	1.250	2.063	0.625	1.125	1.125	0.828	2.063	0.40
25	3.194	JA	1.250	2.063	0.625	1.125	1.125	0.828	2.063	0.44
26	3.314	JA	1.250	2.063	0.625	1.125	1.125	0.828	2.063	0.45
27	3.434	JA	1.250	2.063	0.625	1.125	1.125	0.828	2.063	0.48
28	3.550	JA	1.250	2.063	0.625	1.125	1.125	0.828	2.063	0.52
30	3.793	JA	1.250	2.063	0.625	1.125	1.125	0.828	2.063	0.56
40	4.990	SH	1.688	2.688	0.563	1.438	1.438	1.078	2.688	1.18
42	5.230	SH	1.688	2.688	0.813	1.438	1.438	1.078	2.688	1.26
45	5.590	SH	1.688	2.688	0.813	1.438	1.438	1.078	2.688	1.40
48	5.946	SH	1.688	2.688	0.813	1.438	1.438	1.078	2.688	1.58
54	6.660	SH	1.688	2.688	0.813	1.438	1.438	1.078	2.688	1.88
60	7.380	SH	1.688	2.688	0.813	1.438	1.438	1.078	2.688	2.28
70	8.580	SH	1.688	2.688	0.813	1.438	1.438	1.078	2.688	2.94
72	8.810	SH	1.688	2.688	0.813	1.438	1.438	1.078	2.688	3.14
80	9.770	SH	1.688	2.688	0.813	1.438	1.438	1.078	2.688	3.68
84	10.250	SH	1.688	2.688	0.813	1.438	1.438	1.078	2.688	3.96

\* Please reference QD® bushing dimension table on page 171 for specific information on MAX Bore and keyway data.

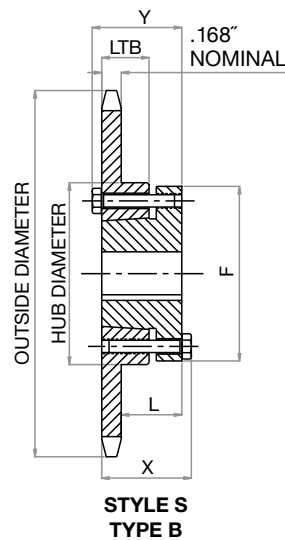



# HOW TO ORDER



## No. 41 1/2" Pitch: PLAIN BORE

Chain Data	
Size	41
Pitch	1/2"
Inside Width	1/4"
Roller Diameter	0.306"
Nominal Tooth Width:	0.227"

How to Order Code: Example Model # for 41 Pitch Plain Bore Carbon Steel Sprockets

<b>A</b>	<b>41</b>	<b>A</b>	<b>36</b>
----------	-----------	----------	-----------

Altered <sup>1</sup>	Chain Pitch in Inches	Hub Type	Number of Teeth				
A: Alteration Required	41: 1/2" Pitch	A: No Hub Extension	15	21	27	40	70
			16	22	28	42	72
			17	23	30	45	80
			18	24	32	48	84
			19	25	35	54	96
			20	26	36	60	112
		B: Hub Extension One Side	8	16	24	36	72
			9	17	25	40	80
			10	18	26	42	84
			11	19	27	45	96
			12	20	28	48	112
			13	21	30	54	
			14	22	32	60	
			15	23	35	70	

<sup>1</sup> Alteration field only to be denoted if a deviation from standard is required. Please reference Alterations in engineering section, page 182.

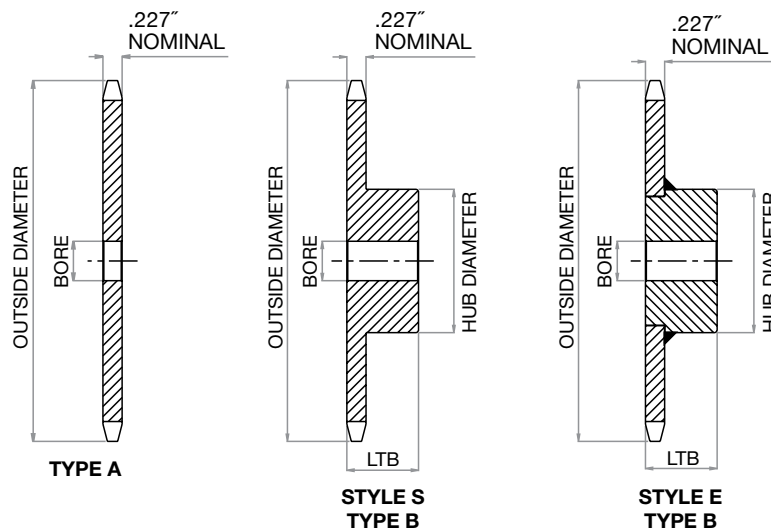

# No. 41

## PLAIN BORE SPROCKET DIMENSIONS

Tsubaki Stock Sprockets

All dimensions in inches unless noted.

No. 41 Plain Bore Sprocket Diameters				Type "A" Plain Bore		Type "B" Plain Bore					
No. Teeth	Outside Diameter	Pitch Diameter	Caliper Diameter	Plain Bore	Wt. Lbs.	Plain Bore	MAX Bore*	Hub Dia.	LTB	Style	Wt. Lbs.
8	1.510	1.307	1.002	NS	NS	0.500	0.500	0.984 <sup>**</sup>	0.875	S	0.19
9	1.670	1.462	1.134	NS	NS	0.500	0.625	1.125 <sup>**</sup>	0.875	S	0.20
10	1.840	1.618	1.312	NS	NS	0.500	0.750	1.250 <sup>**</sup>	0.875	S	0.27
11	2.000	1.775	1.451	NS	NS	0.500	0.875	1.438 <sup>**</sup>	0.875	S	0.35
12	2.170	1.932	1.626	NS	NS	0.500	0.938	1.563 <sup>**</sup>	0.875	S	0.44
13	2.330	2.089	1.768	NS	NS	0.500	1.000	1.563	0.875	S	0.50
14	2.490	2.247	1.941	NS	NS	0.500	1.250	1.750	0.875	S	0.57
15	2.650	2.405	2.086	0.625	0.28	0.500	1.313	1.906	0.875	S	0.72
16	2.810	2.563	2.257	0.625	0.34	0.625	1.375	2.063	0.875	S	0.91
17	2.980	2.721	2.403	0.625	0.36	0.625	1.500	2.234	1.000	S	1.09
18	3.140	2.879	2.573	0.625	0.44	0.625	1.625	2.375	1.000	S	1.25
19	3.300	3.038	2.722	0.625	0.46	0.625	1.750	2.469	1.000	S	1.49
20	3.460	3.355	2.890	0.625	0.52	0.625	1.875	2.750	1.000	S	1.64
21	3.620	3.513	3.040	0.625	0.60	0.625	1.875	2.875	1.000	E	1.81
22	3.780	3.672	3.207	0.625	0.66	0.625	2.000	3.000	1.000	E	1.93
23	3.940	3.672	3.357	0.625	0.72	0.625	2.250	3.188	1.000	E	2.25
24	4.100	3.831	3.525	0.625	0.82	0.625	2.250	3.250	1.000	E	2.33
25	4.200	3.989	3.675	0.625	0.88	0.625	2.250	3.250	1.000	E	2.46
26	4.418	4.148	3.842	0.625	0.94	0.625	2.250	3.250	1.000	E	2.50
27	4.580	4.307	3.994	0.625	1.00	0.625	2.250	3.250	1.000	E	2.56
28	4.740	4.465	4.159	0.625	1.08	0.625	2.250	3.250	1.000	E	2.64
30	5.060	4.783	4.477	0.594	1.20	0.625	2.250	3.250	1.000	E	2.80
32	5.380	5.101	4.794	0.594	1.44	0.625	2.250	3.250	1.000	E	2.96
35	5.860	5.578	5.266	0.594	1.70	0.625	2.375	3.250	1.000	E	3.12
36	6.020	5.737	5.431	0.594	1.84	0.625	2.375	3.250	1.000	E	3.32
40	6.650	6.373	6.067	0.719	2.22	0.750	2.375	3.250	1.063	E	4.06
42	6.970	6.691	6.385	0.719	2.50	0.750	2.375	3.500	1.063	E	4.10
45	7.450	7.168	6.858	0.719	2.52	0.750	2.375	3.500	1.063	E	4.18
48	7.930	7.645	7.339	0.719	2.92	0.750	2.375	3.500	1.063	E	4.92
54	8.880	8.599	8.294	0.719	3.54	0.750	2.375	3.500	1.063	E	5.68
60	9.840	9.544	9.246	0.719	4.60	0.750	2.375	3.500	1.063	E	6.78
70	11.430	11.145	10.840	0.719	6.22	0.750	2.750	4.000	1.188	E	9.54
72	11.750	11.463	11.156	0.719	6.32	0.750	2.750	4.000	1.188	E	9.64
80	13.030	12.736	12.430	0.719	8.46	0.750	2.750	4.000	1.188	E	11.54
84	13.660	13.372	13.067	0.719	9.12	0.750	2.750	4.000	1.188	E	12.20
96	15.570	15.282	14.976	0.938	11.84	1.000	2.750	4.000	1.188	E	14.86
112	18.120	17.827	17.522	0.938	15.84	1.000	2.750	4.000	1.188	E	19.16

\* Dimensions shown allow for standard keyway with set screw at 90 degrees

\*\* Has recessed groove in hub for chain clearance

NS = Non Stock

# HOW TO ORDER

TSUBAKI STOCK SPROCKETS



## No. 41 1/2" Pitch: FINISHED BORE

Chain Data	
Size	41
Pitch	1/2"
Inside Width	1/4"
Roller Diameter	0.306"
Nominal Tooth Width:	0.227"

How to Order Code: Example Model # for 41 Pitch Finished Bore Carbon Steel Sprockets

<b>41</b>	<b>B</b>	<b>36</b>	<b>F -</b>	<b>1B</b>
-----------	----------	-----------	------------	-----------

Chain Pitch in Inches	Hub Type	Number of Teeth				Finished Bore	Hub Bore **		
		9	19	30	70		H:		
41: 1/2" Pitch	B: Hub Extension One Side					F: Sprocket bore supplied with keyway and two set screws	H:	1/2"	(0.500")
							J:	5/8"	(0.625")
							L:	3/4"	(0.750")
							1:	1"	(1.000")
							1B:	1-1/8"	(1.125")
							1C:	1-3/16"	(1.188")
							1D:	1-1/4"	(1.250")
							1F:	1-3/8"	(1.375")
							1G:	1-7/16"	(1.437")
							1H:	1-1/2"	(1.500")

\*\* Hub bore size should be selected from dimensional table on the following page. Bore sizes that are not listed for a given number of sprocket teeth may be available per request as Altered.

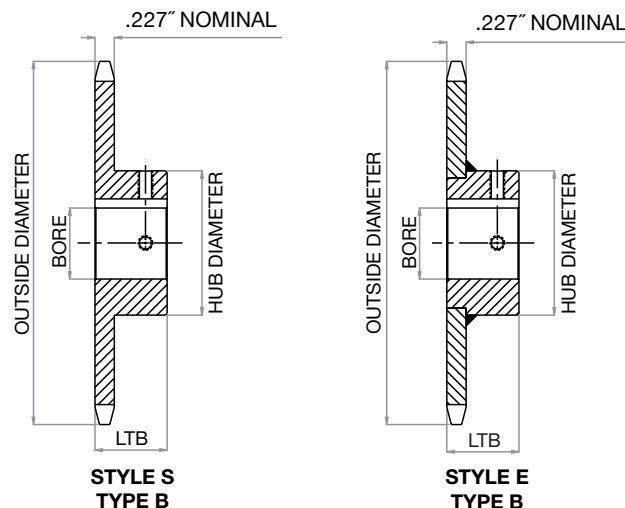

# No. 41

## FINISHED BORE SPROCKET DIMENSIONS

Tsubaki Stock Sprockets

All dimensions in inches unless noted.

No. 41 Finished Bore Sprocket Diameters				Type "F" Bored to Shaft Size (includes standard keyway and two set screws)											Hub Style	Wt. Lbs.
No. Teeth	Outside Diameter	Pitch Diameter	Caliper Diameter	.500" **	.625"	.750"	1.000"	1.125"	1.1888"	1.250"	1.375"	1.438"	1.500"			
9	1.670	1.462	1.134	•	•									S	0.20	
10	1.840	1.618	1.312	•	•									S	0.27	
11	2.000	1.775	1.451	•	•	•								S	0.35	
12	2.170	1.932	1.626	•	•	•								S	0.44	
13	2.330	2.089	1.768	•	•	•	•							S	0.50	
14	2.490	2.247	1.941	•	•	•	•							S	0.57	
15	2.650	2.405	2.086	•	•	•	•							S	0.72	
16	2.810	2.563	2.257		•	•	•							S	0.91	
17	2.980	2.721	2.403		•	•	•							S	1.09	
18	3.140	2.879	2.573		•	•	•							S	1.25	
19	3.300	3.038	2.722		•	•	•							S	1.49	
20	3.460	3.196	2.890		•	•	•							S	1.64	
21	3.620	3.355	3.040		•	•	•							E	1.81	
22	3.780	3.513	3.207		•	•	•							E	1.93	
23	3.940	3.672	3.357		•	•	•							E	2.25	
24	4.100	3.831	3.525		•	•	•							E	2.33	
25	4.200	3.989	3.675		•	•	•							E	2.46	
26	4.418	4.148	3.842		•	•	•							E	2.50	
27	4.580	4.307	3.994		•	•	•							E	2.56	
28	4.740	4.465	4.159		•	•	•							E	2.64	
30	5.060	4.783	4.477		•	•	•							E	2.80	
32	5.380	5.101	4.794		•	•	•							E	2.96	
35	5.860	5.578	5.266		•	•	•							E	3.12	
36	6.020	5.737	5.431		•	•	•							E	3.32	
40	6.650	6.373	6.067			•	•	•	•	•	•	•	•	E	4.06	
42	6.970	6.691	6.385			•	•	•	•	•	•	•	•	E	4.10	
45	7.450	7.168	6.858			•	•	•	•	•	•	•	•	E	4.18	
48	7.930	7.645	7.339			•	•	•	•	•	•	•	•	E	4.92	
54	8.880	8.599	8.294			•	•	•	•	•	•	•	•	E	5.68	
60	9.840	9.544	9.246			•	•	•	•	•	•	•	•	E	6.78	
70	11.430	11.145	10.840			•	•	•	•	•	•	•	•	E	9.54	
72	11.750	11.463	11.156			•	•	•	•	•	•	•	•	E	9.64	
80	13.030	12.736	12.430			•	•	•	•	•	•	•	•	E	11.54	
84	13.660	13.372	13.067			•	•	•	•	•	•	•	•	E	12.20	
96	15.570	15.282	14.976				•	•	•	•	•	•	•	E	14.86	
112	18.120	17.827	17.522				•	•	•	•	•	•	•	E	19.16	

• Denotes stocking item

\*\* Furnished without keyway

# HOW TO ORDER

TSUBAKI STOCK SPROCKETS



## No. 41 1/2" Pitch: TAPER-LOCK®

Chain Data	
Size	41
Pitch	1/2"
Inside Width	1/4"
Roller Diameter	0.306"
Nominal Tooth Width:	0.227"

How to Order Code: Example Model # for 41 Pitch TAPER-LOCK® Carbon Steel Sprockets

<b>A</b>	<b>41</b>	<b>B</b>	<b>TL</b>	<b>18</b>				
Altered <sup>‡</sup>	Chain Pitch in Inches	Hub Type	TAPER-LOCK®	Number of Teeth				
A: Alteration Required	41: 1/2" Pitch	B: Hub Extension One Side	TAPER-LOCK® hub with set screws	14	20	26	40	72
				15	21	28	45	80
				16	22	30	48	96
				17	23	32	54	
				18	24	35	60	
				19	25	36	70	

<sup>‡</sup> Alteration field only to be denoted if a deviation from standard is required. Please reference Alterations in engineering section, page 182.

TAPER-LOCK® bushing is not included with the sprocket. They are to be ordered separately. Please refer to the table below for general guidelines. Specific details are found in the Bushing Section of this catalog beginning on page 164.

TAPER-LOCK® Bushings	
Bushing #	Bore Range
1008	0.500 - 1.000"
1210	0.500 - 1.250"
1610	0.500 - 1.688"

# No. 41

## TAPER-LOCK® SPROCKET DIMENSIONS

Tsubaki Stock Sprockets

All dimensions in inches unless noted.

No. 41 TAPER-LOCK® Sprockets Dia.			Dimensional Data				
No. Teeth	Outside Dia.	Bushing #	MAX Bore*	LTB	Hub Diameter	Hub Style	Weight Lbs.
14	2.490	1008	1.000	0.875	1.875 "	S	0.40
15	2.650	1008	1.000	0.875	1.875	S	0.50
16	2.810	1008	1.000	0.875	2.000	S	0.60
17	2.970	1210	1.250	1.000	2.375 "	S	0.70
18	3.140	1210	1.250	1.000	2.375	S	0.90
19	3.300	1210	1.250	1.000	2.500	S	1.10
20	3.460	1610	1.688	1.000	2.875 "	S	1.10
21	3.620	1610	1.688	1.000	3.000 "	S	1.20
22	3.780	1610	1.688	1.000	3.000	S	1.30
23	3.940	1610	1.688	1.000	3.000	S	1.40
24	4.100	1610	1.688	1.000	3.000	S	1.40
25	4.200	1610	1.688	1.000	3.000	S	1.50
26	4.420	1610	1.688	1.000	3.000	S	1.50
28	4.740	1610	1.688	1.000	3.000	E	1.70
30	5.060	1610	1.688	1.000	3.000	E	1.80
32	5.380	1610	1.688	1.000	3.000	E	1.90
35	5.860	1610	1.688	1.000	3.000	E	2.30
36	6.020	1610	1.688	1.000	3.000	E	2.40
40	6.650	1610	1.688	1.000	3.000	E	2.70
45	7.450	1610	1.688	1.000	3.000	E	3.50
48	7.930	1610	1.688	1.000	3.000	E	4.10
54	8.880	1610	1.688	1.000	3.000	E	4.90
60	9.840	1610	1.688	1.000	3.000	E	5.70
70	11.430	1610	1.688	1.000	3.000	E	7.40
72	11.750	1610	1.688	1.000	3.000	E	8.20
80	13.030	1610	1.688	1.000	3.000	E	9.60
96	15.570	1610	1.688	1.000	3.000	E	13.10

\* Please reference TAPER-LOCK® bushing dimension table on page 165 for specific information on MAX Bore and keyway data.

" Has recessed groove in hub for chain clearance

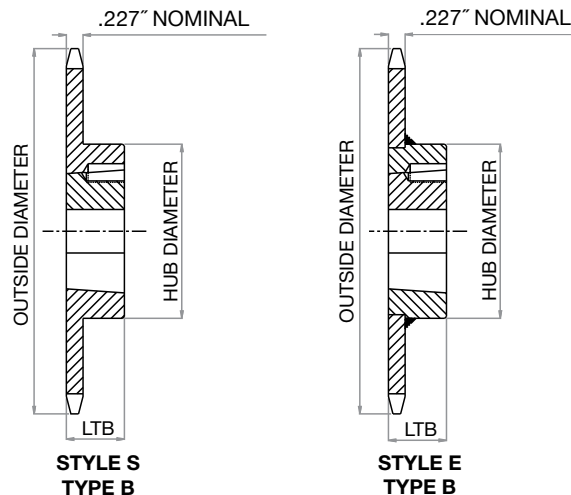

# HOW TO ORDER

TSUBAKI STOCK SPROCKETS



## No. 41 1/2" Pitch: QD®

Chain Data	
Size	41
Pitch	1/2"
Inside Width	1/4"
Roller Diameter	0.306"
Nominal Tooth Width:	0.227"

How to Order Code: Example Model # for 41 Pitch QD® Carbon Steel Sprockets

<b>A</b>	<b>41</b>	<b>JA</b>	<b>19</b>				
Altered <sup>1</sup>	Chain Pitch in Inches	QD® Hub Type	Number of Teeth				
A: Alteration Required	41: 1/2" Pitch	JA: QD® Hub 15 - 19 tooth sprocket	15	17	19		
			16	18			
		SH: QD® Hub 20 - 35 tooth sprocket	20	23	26	30	
			21	24	27	32	
			22	25	28	35	
		SDS: QD® Hub 36 - 60 tooth sprocket	36	42	48	60	
			40	45	54		
		SK: QD® Hub 70 - 112 tooth sprocket	70	80	96		
			72	84	112		

<sup>1</sup>Alteration field only to be denoted if a deviation from standard is required. Please reference Alterations in engineering section, page 182.

QD® bushing is not included with the sprocket. They are to be ordered separately. Please refer to the table below for general guidelines. Specific details are found in the Bushing Section of this catalog beginning on page 170.

QD® Bushings	
Bushing #	Bore Range
JA	0.500 - 1.250"
SH	0.500 - 1.688"
SDS	0.500 - 2.000"
SK	0.500 - 2.625"

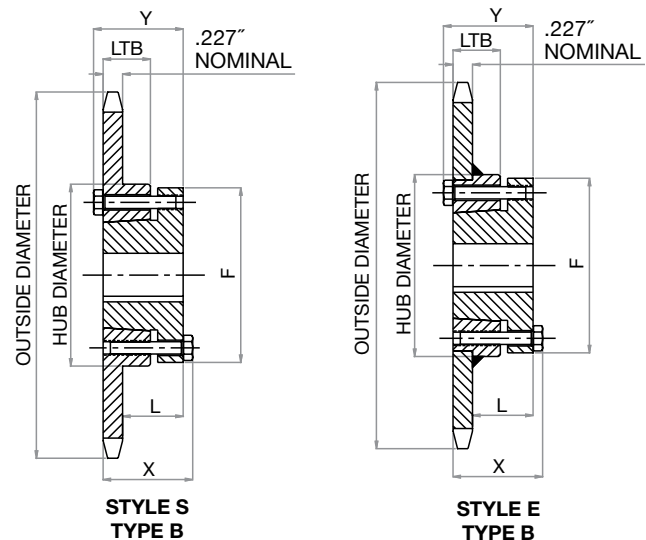

All dimensions in inches unless noted.

No. 41 QD® Sprockets Dia.			Dimensional Data								
No. Teeth	Outside Diameter	Bushing #	MAX Bore*	Hub Diameter	LTB	X	Y	L	F	Hub Style	Weight Lbs.
15	2.650	JA	1.250	2.063	0.625	1.125	1.125	0.766	2.063	S	0.32
16	2.810	JA	1.250	2.063	0.625	1.125	1.125	0.766	2.063	S	0.40
17	2.970	JA	1.250	2.063	0.625	1.125	1.125	0.766	2.063	S	0.50
18	3.140	JA	1.250	2.063	0.625	1.125	1.125	0.766	2.063	S	0.60
19	3.300	JA	1.250	2.063	0.625	1.125	1.125	0.766	2.063	S	0.68
20	3.460	SH	1.688	2.688	0.813	1.438	1.438	1.031	2.688	S	0.78
21	3.620	SH	1.688	2.688	0.813	1.438	1.438	1.031	2.688	S	0.82
22	3.780	SH	1.688	2.688	0.813	1.438	1.438	1.031	2.688	S	1.06
23	3.940	SH	1.688	2.688	0.813	1.438	1.438	1.031	2.688	S	1.14
24	4.100	SH	1.688	2.688	0.813	1.438	1.438	1.031	2.688	S	1.16
25	4.200	SH	1.688	2.688	0.813	1.438	1.438	1.031	2.688	S	1.22
26	4.420	SH	1.688	2.688	0.813	1.438	1.438	1.031	2.688	S	1.26
27	4.580	SH	1.688	2.688	0.813	1.438	1.438	1.031	2.688	S	1.40
28	4.740	SH	1.688	2.688	0.813	1.438	1.438	1.031	2.688	S	1.54
30	5.060	SH	1.688	2.688	0.813	1.438	1.438	1.031	2.688	S	1.58
32	5.380	SH	1.688	2.688	0.813	1.438	1.438	1.031	2.688	S	1.68
35	5.860	SH	1.688	2.688	0.813	1.438	1.438	1.031	2.688	S	2.47
36	6.020	SDS	2.000	3.188	0.750	1.500	1.500	1.094	3.188	E	1.92
40	6.650	SDS	2.000	3.188	0.750	1.500	1.500	1.094	3.188	E	2.32
42	6.970	SDS	2.000	3.188	0.750	1.500	1.500	1.094	3.188	E	2.44
45	7.450	SDS	2.000	3.188	0.750	1.500	1.500	1.094	3.188	E	2.76
48	7.930	SDS	2.000	3.188	0.750	1.500	1.500	1.094	3.188	E	3.36
54	8.880	SDS	2.000	3.188	0.750	1.500	1.500	1.094	3.188	E	3.98
60	9.840	SDS	2.000	3.188	0.750	1.500	1.500	1.094	3.188	E	5.54
70	11.430	SK	2.625	3.875	1.250	2.125	2.125	1.641	3.875	E	7.42
72	11.750	SK	2.625	3.875	1.250	2.125	2.125	1.641	3.875	E	8.02
80	13.030	SK	2.625	3.875	1.250	2.125	2.125	1.641	3.875	E	9.64
84	13.660	SK	2.625	3.875	1.250	2.125	2.125	1.641	3.875	E	10.40
96	15.570	SK	2.625	3.875	1.250	2.125	2.125	1.641	3.875	E	12.82
112	18.120	SK	2.625	3.875	1.250	2.125	2.125	1.641	3.875	E	17.28

\* Please reference QD® bushing dimension table on page 171 for specific information on MAX Bore and keyway data.



# HOW TO ORDER

TSUBAKI STOCK SPROCKETS



No. **40** 1/2" Pitch:  
PLAIN BORE

Chain Data	
Size	40
Pitch	1/2"
Inside Width	5/16"
Roller Diameter	0.312"
Nominal Tooth Width:	0.284"

How to Order Code: Example Model # for 40 Pitch Plain Bore Carbon Steel Sprockets

A	40	A	96				
Altered <sup>11</sup>	Chain Pitch in Inches	Hub Type	Number of Teeth				
A: Alteration Required	40: 1/2" Pitch	A: No Hub Extension	12	23	34	45	56
			13	24	35	46	57
			14	25	36	47	58
			15	26	37	48	59
			16	27	38	49	60
			17	28	39	50	70
			18	29	40	51	72
			19	30	41	52	80
			20	31	42	53	84
			21	32	43	54	96
			22	33	44	55	112
		B: Hub Extension One Side	8	20	32	44	56
			9	21	33	45	57
			10	22	34	46	58
			11	23	35	47	59
			12	24	36	48	60
			13	25	37	49	70
			14	26	38	50	72
			15	27	39	51	80
16	28	40	52	84			
17	29	41	53	96			
18	30	42	54	112			
19	31	43	55				

<sup>11</sup> Alteration field only to be denoted if a deviation from standard is required. Please reference Alterations in engineering section, page 182.

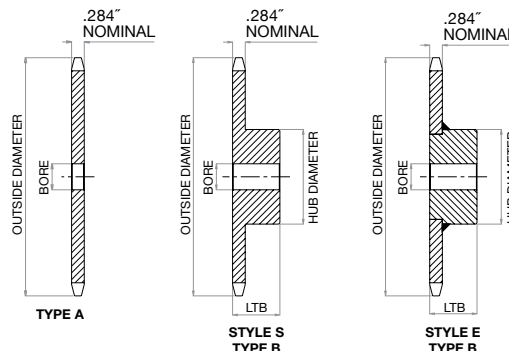

# No. 40

## PLAIN BORE SPROCKET DIMENSIONS

Tsubaki Stock Sprockets

All dimensions in inches unless noted.

No. 40 Plain Bore Sprocket Dia.				Type "A" Plain Bore		Type "B" Plain Bore					
No. Teeth	Outside Dia.	Pitch Dia.	Caliper Dia.	Plain Bore	Wt. Lbs.	Plain Bore	MAX Bore *	Hub Dia.	LTB	Hub Style	Wt. Lbs.
8	1.510	1.307	0.995	NS	NS	0.500	0.500	0.984	0.875	S	0.18
9	1.670	1.462	1.127	NS	NS	0.500	0.563	1.063	0.875	S	0.20
10	1.840	1.618	1.305	NS	NS	0.500	0.750	1.250	0.875	S	0.27
11	2.000	1.775	1.444	NS	NS	0.500	0.875	1.375	0.875	S	0.35
12	2.170	1.932	1.620	0.500	0.18	0.500	1.000	1.563	0.875	S	0.45
13	2.330	2.089	1.761	0.500	0.22	0.500	1.063	1.563	0.875	S	0.50
14	2.490	2.247	1.934	0.500	0.25	0.500	1.125	1.688	0.875	S	0.59
15	2.650	2.405	2.079	0.625	0.30	0.500	1.250	1.813	0.875	S	0.70
16	2.810	2.563	2.250	0.625	0.34	0.625	1.375	2.000	0.875	S	0.79
17	2.980	2.721	2.397	0.625	0.36	0.625	1.438	2.125	1.000	S	1.04
18	3.140	2.879	2.567	0.625	0.44	0.625	1.500	2.313	1.000	S	1.22
19	3.300	3.038	2.715	0.625	0.46	0.625	1.750	2.500	1.000	S	1.43
20	3.460	3.196	2.883	0.625	0.56	0.625	1.875	2.625	1.000	S	1.56
21	3.620	3.355	3.033	0.625	0.58	0.625	1.875	2.750	1.000	S	1.73
22	3.780	3.513	3.201	0.625	0.66	0.625	1.875	2.875	1.000	E	1.96
23	3.940	3.672	3.351	0.625	0.72	0.625	2.000	3.000	1.000	E	2.13
24	4.100	3.831	3.518	0.625	0.82	0.625	2.250	3.250	1.000	E	2.41
25	4.260	3.989	3.669	0.625	0.88	0.625	2.250	3.250	1.000	E	2.54
26	4.420	4.148	3.835	0.625	0.94	0.625	2.250	3.250	1.000	E	2.58
27	4.580	4.307	3.987	0.625	0.98	0.625	2.250	3.250	1.000	E	2.66
28	4.740	4.465	4.153	0.625	1.10	0.625	2.250	3.250	1.000	E	2.73
29	4.900	4.625	4.305	0.594	1.22	0.625	2.250	3.250	1.000	E	2.80
30	5.060	4.783	4.471	0.594	1.25	0.625	2.250	3.250	1.000	E	2.98
31	5.220	4.942	4.623	0.594	1.40	0.625	2.250	3.250	1.000	E	3.10
32	5.380	5.101	4.788	0.594	1.48	0.625	2.250	3.250	1.000	E	3.16
33	5.540	5.260	4.941	0.594	1.56	0.625	2.250	3.250	1.000	E	3.22
34	5.700	5.419	5.107	0.594	1.64	0.625	2.250	3.250	1.000	E	3.30
35	5.860	5.578	5.260	0.594	1.70	0.625	2.250	3.250	1.000	E	3.46
36	6.020	5.737	5.425	0.594	1.84	0.625	2.250	3.250	1.000	E	3.58
37	6.180	5.896	5.578	0.594	1.92	0.625	2.250	3.250	1.000	E	3.62
38	6.330	6.055	5.742	0.594	2.00	0.625	2.250	3.250	1.000	E	3.70
39	6.490	6.214	5.896	0.594	2.02	0.625	2.250	3.250	1.000	E	3.76
40	6.660	6.373	6.061	0.719	2.22	0.750	2.375	3.500	1.125	E	4.69
41	6.810	6.532	6.214	0.719	2.42	0.750	2.375	3.500	1.125	E	4.76
42	6.970	6.691	6.379	0.719	2.50	0.750	2.375	3.500	1.125	E	4.82
43	7.130	6.850	6.532	0.719	2.80	0.750	2.375	3.500	1.125	E	5.12
44	7.290	7.009	6.696	0.719	2.85	0.750	2.375	3.500	1.125	E	5.15
45	7.450	7.168	6.851	0.719	3.15	0.750	2.375	3.500	1.125	E	5.30
46	7.610	7.327	7.014	0.719	3.25	0.750	2.375	3.500	1.125	E	5.57
47	7.770	7.486	7.169	0.719	3.32	0.750	2.375	3.500	1.125	E	5.44
48	7.930	7.645	7.332	0.719	3.22	0.750	2.375	3.500	1.125	E	5.84
49	8.090	7.804	7.487	0.719	3.44	0.750	2.375	3.500	1.125	E	5.90
50	8.250	7.963	7.650	0.719	3.62	0.750	2.375	3.500	1.125	E	5.95
51	8.410	8.124	7.805	0.719	3.94	0.750	2.375	3.500	1.125	E	6.08
52	8.570	8.281	7.968	0.719	4.08	0.750	2.375	3.500	1.125	E	6.28
53	8.730	8.440	8.124	0.719	4.24	0.750	2.375	3.500	1.125	E	6.33
54	8.890	8.599	8.286	0.719	4.44	0.750	2.375	3.500	1.125	E	6.42
55	9.040	8.758	8.442	0.719	4.54	0.750	2.375	3.500	1.125	E	6.46
56	9.200	8.917	8.605	0.719	4.84	0.750	2.375	3.500	1.125	E	6.89
57	9.360	9.077	8.760	0.719	5.00	0.750	2.375	3.500	1.125	E	7.02
58	9.520	9.235	8.924	0.719	5.12	0.750	2.375	3.500	1.125	E	7.35
59	9.680	9.395	9.078	0.719	5.30	0.750	2.375	3.500	1.125	E	7.45
60	9.840	9.554	9.241	0.719	5.48	0.750	2.375	3.500	1.125	E	7.86
70	11.430	11.145	10.832	0.719	7.24	0.750	2.750	4.000	1.250	E	11.00
72	11.750	11.463	11.151	0.719	7.74	0.750	2.750	4.000	1.250	E	11.50
80	13.030	12.736	12.423	0.719	10.20	0.750	2.750	4.000	1.250	E	13.40
84	13.660	13.372	13.059	0.719	10.07	0.750	2.750	4.000	1.250	E	14.04
96	15.570	15.282	14.969	0.938	12.15	1.000	2.750	4.000	1.250	E	17.56
112	18.120	17.827	17.515	0.938	20.00	1.000	2.750	4.000	1.250	E	22.56

\* Dimensions shown allow for standard keyway with set screw at 90 degrees

" Has recessed groove in hub for chain clearance

NS = Non Stock

# HOW TO ORDER

TSUBAKI STOCK SPROCKETS



## No. 40 1/2" Pitch: STAINLESS STEEL PLAIN BORE

Chain Data	
Size	40SS
Pitch	1/2"
Inside Width	5/16"
Roller Diameter	0.312"
Nominal Tooth Width:	0.284"

How to Order Code: Example Model # for 40 Pitch Plain Bore Stainless Steel Sprockets

<b>A</b>	<b>40</b>	<b>B</b>	<b>25</b>				<b>SS</b>	
Altered <sup>1</sup>	Chain Pitch in Inches	Hub Type	Number of Teeth					Material
A: Alteration Required	40: 1/2" Pitch	A: No Hub Extension	24	28	35	45		SS: 304 Stainless Steel Construction
			26	30	40	60		
		B: Hub Extension One Side	10	15	20	25	40	
			11	16	21	26	45	
			12	17	22	28	60	
			13	18	23	30		
			14	19	24	35		

<sup>1</sup>Alteration field only to be denoted if a deviation from standard is required. Please reference Alterations in engineering section, page 182.

# No. 40

## STAINLESS STEEL SPROCKET DIMENSIONS

Tsubaki Stock Sprockets

All dimensions in inches unless noted.

No. 40 Stainless Steel Sprocket Diameters				Type "A" Plain Bore		Type "B" Plain Bore					
No. Teeth	Outside Diameter	Pitch Diameter	Caliper Diameter	Plain Bore	Wt. Lbs.	Plain Bore	MAX Bore *	Hub Dia.	LTB	Hub Style	Wt. Lbs.
10	1.840	1.618	1.305	N/A	N/A	0.500	0.750	1.250	0.875	S	0.28
11	2.000	1.775	1.444	N/A	N/A	0.500	0.813	1.375	0.875	S	0.36
12	2.170	1.932	1.620	N/A	N/A	0.500	0.938	1.563	0.875	S	0.44
13	2.330	2.089	1.761	N/A	N/A	0.500	1.063	1.563	0.875	S	0.50
14	2.490	2.247	1.934	N/A	N/A	0.500	1.125	1.688	0.875	S	0.60
15	2.650	2.405	2.079	N/A	N/A	0.500	1.250	1.813	0.875	S	0.68
16	2.810	2.563	2.250	N/A	N/A	0.625	1.375	2.000	0.875	S	0.82
17	2.980	2.721	2.397	N/A	N/A	0.625	1.438	2.125	1.000	S	1.06
18	3.140	2.879	2.567	N/A	N/A	0.625	1.500	2.313	1.000	S	1.24
19	3.300	3.038	2.715	N/A	N/A	0.625	1.750	2.500	1.000	S	1.42
20	3.460	3.196	2.883	N/A	N/A	0.625	1.875	2.625	1.000	S	1.60
21	3.620	3.355	3.033	N/A	N/A	0.625	1.875	2.750	1.000	S	1.68
22	3.780	3.513	3.201	N/A	N/A	0.625	1.875	2.875	1.000	S	1.81
23	3.940	3.672	3.351	N/A	N/A	0.625	2.000	3.000	1.000	S	2.18
24	4.100	3.831	3.518	0.594	0.80	0.625	2.250	3.250	1.000	D	2.20
25	4.260	3.989	3.669	N/A	N/A	0.625	2.250	3.250	1.000	D	2.39
26	4.420	4.148	3.835	0.594	1.31	0.625	2.250	3.250	1.000	D	2.40
28	4.740	4.465	4.153	0.594	1.35	0.625	2.250	3.250	1.000	D	2.75
30	5.060	4.783	4.471	0.594	1.39	0.625	2.250	3.250	1.000	D	2.88
35	5.860	5.578	5.260	0.594	1.92	0.625	2.250	3.250	1.000	D	3.32
40	6.650	6.373	6.061	0.719	2.36	0.750	2.375	3.500	1.000	D	4.28
45	7.450	7.168	6.851	0.719	3.13	0.750	2.375	3.500	1.000	D	4.68
60	9.840	9.554	9.241	0.719	5.50	0.750	2.375	3.500	1.000	D	7.00

\* Dimension depicted allows for standard keyway with set screw at 90 degrees

'' Has recessed groove in hub for chain clearance

N/A = Not Available

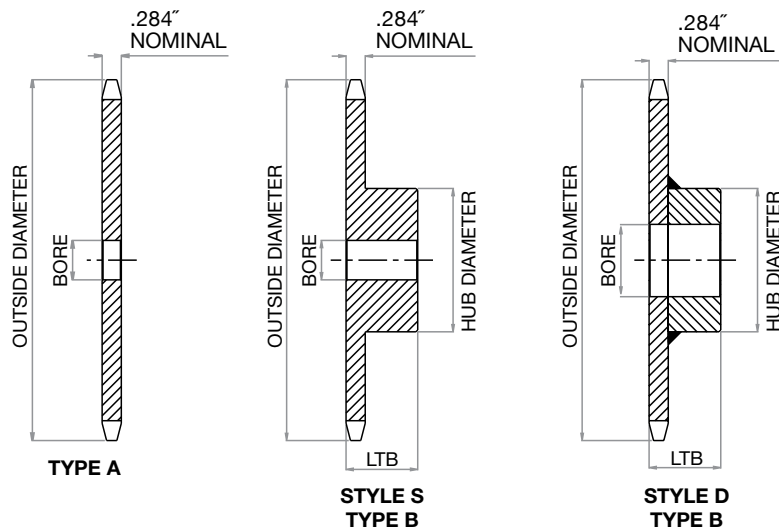

# HOW TO ORDER

TSUBAKI STOCK SPROCKETS



## No. 40 1/2" Pitch: FINISHED BORE

Chain Data	
Size	40
Pitch	1/2"
Inside Width	5/16"
Roller Diameter	0.312"
Nominal Tooth Width:	0.284"

How to Order Code: Example Model # for 40 Pitch Finished Bore Carbon Steel Sprockets

<b>40</b>	<b>B</b>	<b>60</b>	<b>F -</b>	<b>1B</b>
-----------	----------	-----------	------------	-----------

Chain Pitch in Inches	Hub Type	Number of Teeth					Finished Bore	Hub Bore **			
		9	21	33	45	57		H:			
40: 1/2" Pitch	B: Hub Extension One Side						F: Hub Extension Machined with keyway and two set screws	H:	1/2"	(0.500")	
								J:	5/8"	(0.625")	
								L:	3/4"	(0.750")	
								P:	7/8"	(0.875")	
								1:	1"	(1.000")	
								1B:	1-1/8"	(1.125")	
								1C:	1-3/16"	(1.188")	
								1D:	1-1/4"	(1.250")	
								1F:	1-3/8"	(1.375")	
								1G:	1-7/16"	(1.437")	
								1H:	1-1/2"	(1.500")	

\*\* Hub bore size should be selected from dimensional table on the following page. Bore sizes that are not listed for a given number of sprocket teeth may be available per request as Altered.

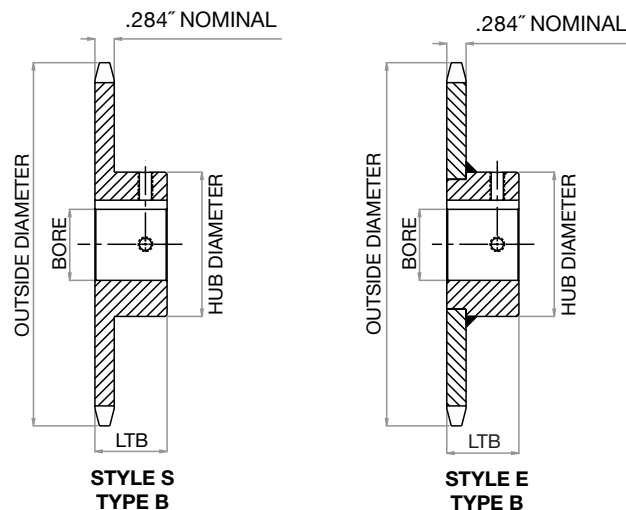

# No. 40

## FINISHED BORE SPROCKET DIMENSIONS

Tsubaki Stock Sprockets

All dimensions in inches unless noted.

No. 40 Sprocket Diameters				Type "F" Bored to Shaft Size (includes standard keyway and two set screws)												
No. Teeth	Outside Dia.	Pitch Dia.	Caliper Dia.	.500 <sup>**</sup>	.625"	.750"	.875"	1.000"	1.125"	1.187"	1.250"	1.375"	1.438"	1.500"	Hub Style	Wt. Lbs.
9	1.674	1.462	1.127	•	•										S	0.20
10	1.839	1.618	1.305	•	•	•									S	0.27
11	2.003	1.775	1.444	•	•	•	•								S	0.35
12	2.166	1.932	1.620	•	•	•	•	•							S	0.45
13	2.328	2.089	1.761	•	•	•	•	•							S	0.50
14	2.490	2.247	1.934	•	•	•	•	•							S	0.59
15	2.652	2.405	2.079	•	•	•	•	•	•	■	■				S	0.70
16	2.814	2.563	2.250	•	•	•	•	•	•	•	•				S	0.79
17	2.974	2.721	2.397	•	•	•	•	•	•	•	•				S	1.04
18	3.136	2.879	2.567	•	•	•	•	•	•	•	•	•	■	■	S	1.22
19	3.292	3.038	2.715	•	•	•	•	•	•	•	•	•	•	•	S	1.43
20	3.457	3.196	2.883	•	•	•	•	•	•	•	•	•	•	•	S	1.56
21	3.618	3.355	3.033	•	•	•	•	•	•	•	•	•	•	•	S	1.73
22	3.778	3.513	3.201	•	•	•	•	•	•	•	•	•	•	•	E	1.96
23	3.938	3.672	3.351	•	•	•	•	•	•	•	•	•	•	•	E	2.13
24	4.098	3.831	3.518	•	•	•	•	•	•	•	•	•	•	•	E	2.41
25	4.258	3.989	3.669	•	•	•	•	•	•	•	•	•	•	•	E	2.54
26	4.418	4.148	3.835	•	•	•	•	•	•	•	•	•	•	•	E	2.58
27	4.578	4.307	3.987	•	•	•	•	•	•	•	•	•	•	•	E	2.66
28	4.738	4.465	4.153	•	•	•	•	•	•	•	•	•	•	•	E	2.73
29	4.900	4.625	4.305	•	•	•	•	•	•	•	•	•	•	•	E	2.80
30	5.057	4.783	4.471	•	•	•	•	•	•	•	•	•	•	•	E	2.98
31	5.220	4.942	4.623	•	•	•	•	•	•	•	•	•	•	•	E	3.10
32	5.376	5.101	4.788	•	•	•	•	•	•	•	•	•	•	•	E	3.16
33	5.540	5.260	4.941	•	•	•	•	•	•	•	•	•	•	•	E	3.22
34	5.696	5.419	5.107	•	•	•	•	•	•	•	•	•	•	•	E	3.30
35	5.856	5.578	5.260	•	•	•	•	•	•	•	•	•	•	•	E	3.46
36	6.015	5.737	5.425	•	•	•	•	•	•	•	•	•	•	•	E	3.58
37	6.170	5.896	5.578	•	•	•	•	•	•	•	•	•	•	•	E	3.62
38	6.334	6.055	5.742	•	•	•	•	•	•	•	•	•	•	•	E	3.70
39	6.490	6.214	5.896	•	•	•	•	•	•	•	•	•	•	•	E	3.76
40	6.653	6.373	6.061	•	•	•	•	•	•	•	•	•	•	•	E	4.69
41	6.810	6.532	6.214	•	•	•	•	•	•	•	•	•	•	•	E	4.76
42	6.972	6.691	6.379	•	•	•	•	•	•	•	•	•	•	•	E	4.82
43	7.130	6.850	6.532	•	•	•	•	•	•	•	•	•	•	•	E	5.12
44	7.290	7.009	6.696	•	•	•	•	•	•	•	•	•	•	•	E	5.15
45	7.450	7.168	6.851	•	•	•	•	•	•	•	•	•	•	•	E	5.30
46	7.610	7.327	7.014	•	•	•	•	•	•	•	•	•	•	•	E	5.57
47	7.770	7.486	7.169	•	•	•	•	•	•	•	•	•	•	•	E	5.44
48	7.930	7.645	7.332	•	•	•	•	•	•	•	•	•	•	•	E	5.84
49	8.090	7.804	7.487	•	•	•	•	•	•	•	•	•	•	•	E	5.90
50	8.250	7.963	7.650	•	•	•	•	•	•	•	•	•	•	•	E	5.95
51	8.410	8.122	7.805	•	•	•	•	•	•	•	•	•	•	•	E	6.08
52	8.570	8.281	7.968	•	•	•	•	•	•	•	•	•	•	•	E	6.28
53	8.730	8.440	8.124	•	•	•	•	•	•	•	•	•	•	•	E	6.33
54	8.890	8.599	8.286	•	•	•	•	•	•	•	•	•	•	•	E	6.42
55	9.040	8.758	8.442	•	•	•	•	•	•	•	•	•	•	•	E	6.46
56	9.200	8.917	8.605	•	•	•	•	•	•	•	•	•	•	•	E	6.89
57	9.360	9.077	8.760	•	•	•	•	•	•	•	•	•	•	•	E	7.02
58	9.520	9.235	8.924	•	•	•	•	•	•	•	•	•	•	•	E	7.35
59	9.680	9.395	9.078	•	•	•	•	•	•	•	•	•	•	•	E	7.45
60	9.840	9.554	9.241	•	•	•	•	•	•	•	•	•	•	•	E	7.86
70	11.430	11.145	10.832	•	•	•	•	•	•	•	•	•	•	•	E	11.00
72	11.750	11.463	11.151	•	•	•	•	•	•	•	•	•	•	•	E	11.50
80	13.030	12.736	12.423	•	•	•	•	•	•	•	•	•	•	•	E	13.40
84	13.660	13.372	13.059	•	•	•	•	•	•	•	•	•	•	•	E	14.04
96	15.570	15.282	14.969	•	•	•	•	•	•	•	•	•	•	•	E	17.56
112	18.120	17.827	17.515	•	•	•	•	•	•	•	•	•	•	•	E	22.56

• Denotes stocked item

■ Indicates ser screw at 90 degrees and 180 degrees from keyway

\*\* Furnished without keyway

# HOW TO ORDER

TSUBAKI STOCK SPROCKETS



## No. 40 1/2" Pitch: MULTI-STRAND

Chain Data	
Size	40-2, 40-3
Pitch	1/2"
Inside Width	5/16"
Roller Diameter	0.312"
Nominal Tooth Width:	0.275"

How to Order Code: Example Model # for 40 Pitch Multi-Strand Carbon Steel Sprockets

<b>A</b>	<b>D</b>	<b>40</b>	<b>B</b>	<b>18</b>				
Altered <sup>#</sup>	Multi	Chain Pitch in Inches	Hub Type	Number of Teeth				
A: Alteration Required	D: Double Strand	40: 1/2" Pitch	B: Hub Extension One Side	Double Strand				
				11	17	23	36	54
				12	18	24	40	60
				13	19	25	42	
				14	20	26	45	
				15	21	30	48	
	T: Triple Strand			Triple Strand				
				11	15	19	23	30
				12	16	20	24	35
				13	17	21	25	36
				14	18	22	26	

<sup>#</sup> Alteration field only to be denoted if a deviation from standard is required. Please reference Alterations in engineering section, page 182.

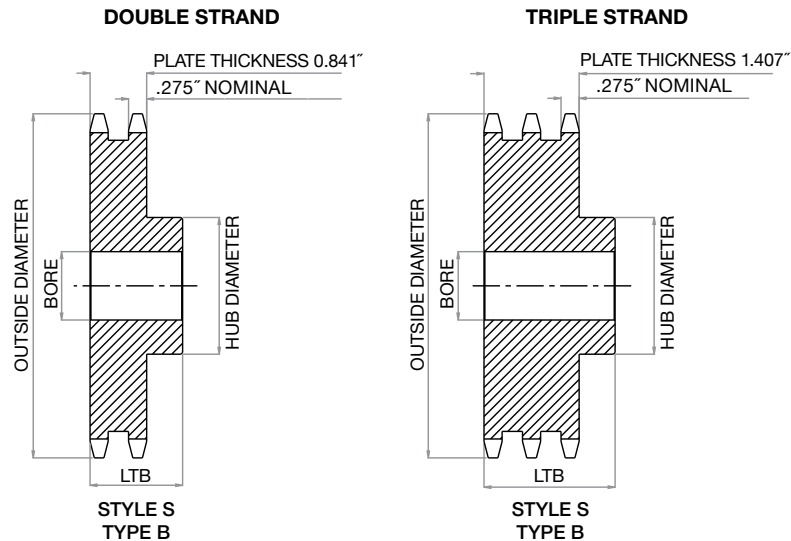

# No. 40

## MULTI-STRAND SPROCKET DIMENSIONS

Tsubaki Stock Sprockets

All dimensions in inches unless noted.

No. 40 Multi Strand Sprocket Dia.			Dimensional Data: Double Strand Sprockets				
No. Teeth	Outside Dia.	Plain Bore	Hub Diameter	LTB	MAX Bore +	Hub Style	Weight Lbs.
11	2.003	0.500	1.438 "	1.500	0.750	S	0.62
12	2.166	0.500	1.563 "	1.500	0.938	S	0.76
13	2.328	0.500	1.500	1.500	1.000	S	0.86
14	2.490	0.500	1.688	1.500	1.125	S	1.08
15	2.652	0.500	1.813	1.500	1.250	S	1.24
16	2.814	0.625	2.000	1.500	1.375	S	1.42
17	2.974	0.625	2.125	1.500	1.438	S	1.64
18	3.136	0.625	2.313	1.500	1.500	S	1.92
19	3.292	0.625	2.500	1.500	1.750	S	2.22
20	3.457	0.625	2.625	1.625	1.875	S	2.64
21	3.618	0.625	2.750	1.625	1.875	S	2.94
22	3.778	0.625	2.875	1.625	1.875	S	3.18
23	3.938	0.625	3.000	1.625	2.000	S	3.52
24	4.098	0.625	3.250	1.625	2.250	S	4.04
25	4.258	0.625	3.250	1.625	2.250	S	4.26
26	4.418	0.625	3.250	1.625	2.250	S	4.48
30	5.057	0.875	3.250	1.625	2.250	S	5.34
35	5.856	0.875	3.250	1.625	2.250	S	6.80
36	6.015	0.938	3.750	1.625	2.500	S	7.20
40	6.653	0.938	3.750	1.750	2.500	S	9.40
42	6.972	0.938	3.750	1.750	2.500	S	10.20
45	7.450	0.938	3.750	1.750	2.500	S	11.36
48	7.930	0.938	3.750	1.750	2.500	S	12.66
52	8.570	0.938	3.750	1.750	2.500	S	14.46
54	8.890	0.938	3.750	1.750	2.500	S	15.48
60	9.840	0.938	3.750	1.750	2.500	S	18.60

+ Dimension depicted allows for standard keyway with set screw at 90 degrees

" Has recessed groove in hub for chain clearance

All dimensions in inches unless noted.

No. 40 Multi Strand Sprocket Dia.			Dimensional Data: Triple Strand Sprockets				
No. Teeth	Outside Dia.	Plain Bore	Hub Diameter	LTB	MAX Bore +	Hub Style	Weight Lbs.
11	2.003	0.500	1.438 "	2.125	0.750	S	0.80
12	2.166	0.500	1.563 "	2.125	0.938	S	1.10
13	2.328	0.500	1.500	2.125	1.000	S	1.24
14	2.490	0.500	1.688	2.125	1.125	S	1.50
15	2.652	0.500	1.813	2.125	1.250	S	1.76
16	2.814	0.625	2.000	2.125	1.375	S	2.04
17	2.974	0.625	2.125	2.125	1.438	S	2.34
18	3.136	0.625	2.313	2.125	1.500	S	2.72
19	3.292	0.625	2.500	2.125	1.750	S	3.10
20	3.457	0.625	2.625	2.250	1.875	S	3.72
21	3.618	0.625	2.750	2.250	1.875	S	4.06
22	3.778	0.625	2.875	2.250	1.875	S	4.52
23	3.938	0.625	3.000	2.250	2.000	S	4.96
24	4.098	0.625	3.250	2.250	2.250	S	5.64
25	4.258	0.625	3.250	2.250	2.250	S	6.02
26	4.418	0.625	3.250	2.250	2.250	S	6.36
30	5.057	0.875	3.250	2.250	2.250	S	7.84
35	5.856	0.875	3.250	2.250	2.250	S	10.30
36	6.015	0.938	3.750	2.375	2.500	S	11.72

+ Dimension depicted allows for standard keyway with set screw at 90 degrees

" Has recessed groove in hub for chain clearance



# HOW TO ORDER

TSUBAKI STOCK SPROCKETS



## No. 40 1/2" Pitch: DOUBLE SINGLE

Chain Data	
Size	40
Pitch	1/2"
Inside Width	5/16"
Roller Diameter	0.312"
Nominal Tooth Width:	0.284"

How to Order Code: Example Model # for 40 Pitch Double Single Carbon Steel Sprockets

<b>A</b>	<b>DS</b>	<b>40</b>	<b>A</b>	<b>18</b>			
Altered <sup>!!</sup>	Multi	Chain Pitch in Inches	Hub Type	Number of Teeth			
A: Alteration Required	DS: Double Single	40: 1/2" Pitch	A: No Hub Extension	15	18	21	24
				16	19	22	
				17	20	23	

<sup>!!</sup>Alteration field only to be denoted if a deviation from standard is required. Please reference Alterations in engineering section, page 182.

How to Order Code: Example Model # for 40 Pitch Double Single TAPER-LOCK® Carbon Steel Sprockets

<b>A</b>	<b>DS</b>	<b>40</b>	<b>A</b>	<b>TL</b>	<b>21</b>			
Altered <sup>!!</sup>	Multi	Chain Pitch in Inches	Hub Type	TAPER-LOCK®	Number of Teeth			
A: Alteration Required	DS: Double Single	40: 1/2" Pitch	A: No Hub Extension	TAPER-LOCK® hub with set screws	19	21	24	
					20	23		

<sup>!!</sup>Alteration field only to be denoted if a deviation from standard is required. Please reference Alterations in engineering section, page 182.

TAPER-LOCK® bushing is not included with the sprocket. They are to be ordered separately. Please refer to the table below for general guidelines. Specific details are found in the Bushing Section of this catalog beginning on page 164.

TAPER-LOCK® Bushings	
Bushing #	Bore Range
1215	0.500 - 1.250"
1615	0.500 - 1.688"

# No. 40

## DOUBLE SINGLE SPROCKET DIMENSIONS

Tsubaki Stock Sprockets

All dimensions in inches unless noted.

No. 40 Double Single Sprocket Dia.			Dimensional Data				
No. Teeth	Outside Dia.	Plain Bore	LTB	C	D	MAX Bore +	Weight Lbs.
15	2.650	0.500	1.406	1.125	1.813	1.250	1.20
16	2.810	0.500	1.406	1.125	2.000	1.250	1.40
17	2.980	0.500	1.406	1.125	2.125	1.313	1.60
18	3.140	0.500	1.406	1.125	2.313	1.500	1.80
19	3.300	0.625	1.406	1.125	2.500	1.688	2.20
20	3.460	0.625	1.406	1.125	2.625	1.750	2.60
21	3.620	0.625	1.406	1.125	2.781	1.750	2.90
22	3.780	0.625	1.406	1.125	2.938	1.938	3.00
23	3.940	0.625	1.406	1.125	3.094	2.063	3.50
24	4.100	0.625	1.406	1.125	3.266	2.250	4.00

+ Dimension depicted allows for standard keyway with set screw at 90 degrees

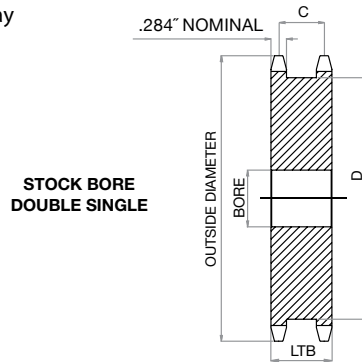

All dimensions in inches unless noted.

No. 40 Double Single TAPER-LOCK® Sprocket Diameters			Dimensional Data				
No. Teeth	Outside Dia.	Plain Bore	LTB	C	Bushing #	MAX Bore*	Weight Lbs.
19	3.300	0.500	1.406	1.125	1215	1.250	1.10
20	3.460	0.500	1.406	1.125	1215	1.250	1.30
21	3.620	0.500	1.406	1.125	1615	1.688	1.30
23	3.940	0.500	1.406	1.125	1615	1.688	1.50
24	4.100	0.500	1.406	1.125	1615	1.688	1.70

\* Please reference TAPER-LOCK® bushing dimension table on page 165 for specific information on MAX Bore and keyway data.

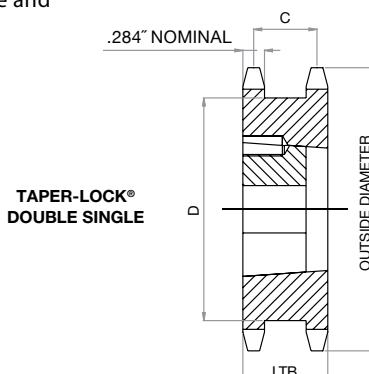

# HOW TO ORDER

TSUBAKI STOCK SPROCKETS



## No. 40 1/2" Pitch: TAPER-LOCK®

Chain Data	
Size	40
Pitch	1/2"
Inside Width	5/16"
Roller Diameter	0.312"
Nominal Tooth Width:	0.284"

How to Order Code: Example Model # for 40 Pitch TAPER-LOCK® Carbon Steel Sprockets

<b>A</b>	<b>40</b>	<b>B</b>	<b>TL</b>	<b>42</b>				
Altered <sup>‡</sup>	Chain Pitch in Inches	Hub Type	TAPER-LOCK®	Number of Teeth				
A: Alteration Required	40: 1/2" Pitch	B: Hub Extension One Side	TAPER-LOCK® hub with set screws	14	20	26	40	70
				15	21	28	42	72
				16	22	30	45	80
				17	23	32	48	84
				18	24	35	54	96
				19	25	36	60	

<sup>‡</sup> Alteration field only to be denoted if a deviation from standard is required. Please reference Alterations in engineering section, page 182.

TAPER-LOCK® bushing is not included with the sprocket. They are to be ordered separately. Please refer to the table below for general guidelines. Specific details are found in the Bushing Section of this catalog beginning on page 164.

TAPER-LOCK® Bushings	
Bushing #	Bore Range
1008	0.500 - 1.000"
1210	0.500 - 1.250"
1610	0.500 - 1.688"
2012	0.500 - 2.125"

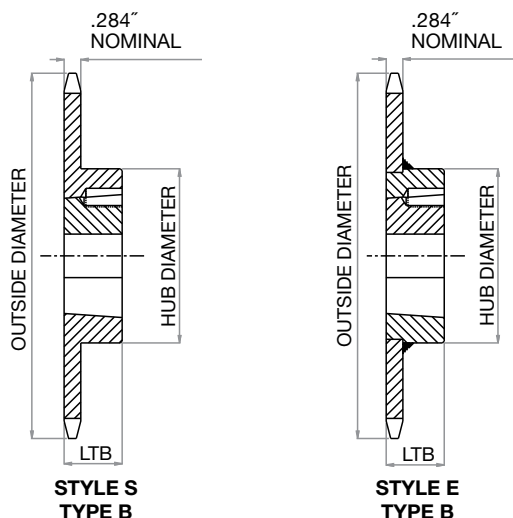

# No. 40

## TAPER-LOCK® SPROCKET DIMENSIONS

Tsubaki Stock Sprockets

All dimensions in inches unless noted.

No. 40 TAPER-LOCK® Sprockets Dia.			Dimensional Data TAPER-LOCK® Sprockets				
No. Teeth	Outside Diameter	Bushing #	MAX Bore*	LTB	Hub Diameter	Hub Style	Weight Lbs.
14	2.491	1008	1.000	0.875	1.813 **	S	0.30
15	2.652	1008	1.000	0.875	1.813	S	0.40
16	2.814	1008	1.000	0.875	1.938	S	0.50
17	2.975	1210	1.250	1.000	2.375 **	S	0.50
18	3.135	1210	1.250	1.000	2.469 **	S	0.60
19	3.296	1210	1.250	1.000	2.469	S	0.70
20	3.457	1610	1.688	1.000	2.781 **	S	0.70
21	3.617	1610	1.688	1.000	2.781	S	0.80
22	3.778	1610	1.688	1.000	2.781	S	0.90
23	3.938	1610	1.688	1.000	3.094	S	1.00
24	4.098	1610	1.688	1.000	3.250	S	1.40
25	4.258	1610	1.688	1.000	3.406	S	1.50
26	4.418	1610	1.688	1.000	3.500	S	1.70
28	4.738	1610	1.688	1.000	3.500	E	1.80
30	5.057	1610	1.688	1.000	3.500	E	1.90
32	5.377	1610	1.688	1.000	3.500	E	1.90
35	5.855	1610	1.688	1.000	3.500	E	2.30
36	6.015	1610	1.688	1.000	3.000	E	2.40
40	6.653	1610	1.688	1.000	3.000	E	2.80
42	6.970	1610	1.688	1.000	3.000	E	2.90
45	7.450	1610	1.688	1.000	3.000	E	3.50
48	7.928	1610	1.688	1.000	3.000	E	4.00
54	8.885	1610	1.688	1.000	3.000	E	4.90
60	9.841	1610	1.688	1.000	3.000	E	6.00
70	11.434	2012	2.125	1.250	3.563	E	8.20
72	11.752	2012	2.125	1.250	3.563	E	9.00
80	13.026	2012	2.125	1.250	3.563	E	10.80
84	13.663	2012	2.125	1.250	3.563	E	11.30
96	15.573	2012	2.125	1.250	3.563	E	14.60

\* Please reference TAPER-LOCK® bushing dimension table on page 165 for specific information on MAX Bore and keyway data.

\*\* Has recessed groove in hub for chain clearance

# HOW TO ORDER

TSUBAKI STOCK SPROCKETS



## No. 40 1/2" Pitch: QD®

Chain Data	
Size	40
Pitch	1/2"
Inside Width	5/16"
Roller Diameter	0.312"
Nominal Tooth Width:	0.284"

How to Order Code: Example Model # for 40 Pitch QD® Carbon Steel Sprockets

A	40	JA	19			
Altered <sup>!!</sup>	Chain Pitch in Inches	QD® Hub Type	Number of Teeth			
A: Alteration Required	40: 1/2" Pitch	JA: QD® Hub 15 - 19 tooth sprocket	15	17	19	
			16	18		
		SH: QD® Hub 20 - 35 tooth sprocket	20	23	26	30
			21	24	27	32
			22	25	28	35
		SDS: QD® Hub 36 - 60 tooth sprocket	36	42	48	60
			40	45	54	
		SK: QD® Hub 70 - 112 tooth sprocket	70	80	96	
			72	84	112	

<sup>!!</sup>Alteration field only to be denoted if a deviation from standard is required. Please reference Alterations in engineering section, page 182.

QD® bushing is not included with the sprocket. They are to be ordered separately. Please refer to the table below for general guidelines. Specific details are found in the Bushing Section of this catalog beginning on page 170.

QD® Bushings	
Bushing #	Bore Range
JA	0.500 - 1.250"
SH	0.500 - 1.688"
SDS	0.500 - 2.000"
SK	0.500 - 2.625"

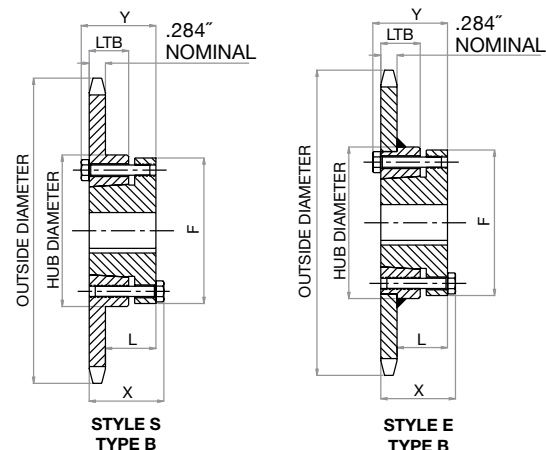

# No. 40

## QD® SPROCKET DIMENSIONS

Tsubaki Stock Sprockets

All dimensions in inches unless noted.

No. 40 QD® Sprockets Dia.			Dimensional Data								
No. Teeth	Outside Diameter	Bushing #	MAX Bore*	Hub Diameter	LTB	X	Y	L	F	Hub Style	Weight Lbs.
15	2.650	JA	1.250	2.063 "	0.625	1.125	1.125	0.719	2.063	S	0.34
16	2.810	JA	1.250	2.063 "	0.625	1.125	1.125	0.719	2.063	S	0.40
17	2.980	JA	1.250	2.188 "	0.625	1.125	1.125	0.719	2.063	S	0.48
18	3.140	JA	1.250	2.250 "	0.625	1.125	1.125	0.719	2.063	S	0.54
19	3.300	JA	1.250	2.250 "	0.625	1.125	1.125	0.719	2.063	S	0.60
20	3.460	SH	1.688	2.750 "	0.813	1.438	1.438	0.969	2.688	S	0.76
21	3.620	SH	1.688	2.750 "	0.813	1.438	1.438	0.969	2.688	S	0.84
22	3.780	SH	1.688	3.000	0.813	1.438	1.438	0.969	2.688	S	0.92
23	3.940	SH	1.688	3.000	0.813	1.438	1.438	0.969	2.688	S	1.14
24	4.100	SH	1.688	3.000	0.813	1.438	1.438	0.969	2.688	S	1.22
25	4.260	SH	1.688	3.000	0.813	1.438	1.438	0.969	2.688	S	1.30
26	4.420	SH	1.688	3.000	0.813	1.438	1.438	0.969	2.688	S	1.44
27	4.580	SH	1.688	3.000	0.813	1.438	1.438	0.969	2.688	S	1.46
28	4.740	SH	1.688	3.000	0.813	1.438	1.438	0.969	2.688	S	1.54
30	5.060	SH	1.688	3.000	0.813	1.438	1.438	0.969	2.688	S	1.72
32	5.360	SH	1.688	3.000	0.813	1.438	1.438	0.969	2.688	S	1.90
35	5.860	SH	1.688	3.000	0.813	1.438	1.438	0.969	3.000	S	2.22
36	6.020	SDS	2.000	3.500	0.750	1.500	1.500	1.032	3.188	E	2.20
40	6.660	SDS	2.000	3.500	0.750	1.500	1.500	1.032	3.188	E	2.72
42	6.970	SDS	2.000	3.500	0.750	1.500	1.500	1.032	3.188	E	2.92
45	7.450	SDS	2.000	3.500	0.750	1.500	1.500	1.032	3.188	E	3.32
48	7.930	SDS	2.000	3.500	0.750	1.500	1.500	1.032	3.188	E	3.70
54	8.890	SDS	2.000	3.500	0.750	1.500	1.500	1.032	3.188	E	4.78
60	9.840	SDS	2.000	3.500	0.750	1.500	1.500	1.032	3.188	E	5.86
70	11.430	SK	2.625	4.250	1.250	2.125	2.125	1.594	3.875	E	8.68
72	11.750	SK	2.625	4.250	1.250	2.125	2.125	1.594	3.875	E	8.84
80	13.030	SK	2.625	4.250	1.250	2.125	2.125	1.594	3.875	E	11.20
84	13.660	SK	2.625	4.250	1.250	2.125	2.125	1.594	3.875	E	11.56
96	15.570	SK	2.625	4.250	1.250	2.125	2.125	1.594	3.875	E	15.76
112	18.120	SK	2.625	4.250	1.250	2.125	2.125	1.594	3.875	E	20.28

\* Please reference QD® bushing dimension table on page 171 for specific information on MAX Bore and keyway data.

" Has recessed groove in hub for chain clearance

# HOW TO ORDER

TSUBAKI STOCK SPROCKETS



No.  
**40**

**1/2" Pitch:  
MULTI-STRAND TAPER-LOCK®**

Chain Data	
Size	40 - 2
Pitch	1/2"
Inside Width	5/16"
Roller Diameter	0.312"
Nominal Tooth Width:	0.275"

How to Order Code: Example Model # for 40 Pitch Multi-Strand TAPER-LOCK® Carbon Steel Sprockets

<b>A</b>	<b>D</b>	<b>40</b>	<b>C</b>	<b>TL</b>	<b>42</b>			
Altered <sup>!</sup>	Multi-Strand	Chain Pitch in Inches	Hub Type	TAPER-LOCK®	Number of Teeth			
A: Alteration Required	D: Double Strand	40: 1/2" Pitch	A: No Hub Extension	TAPER-LOCK® hub with set screws	A Style			
					15	16	17	
			B: Hub Extension One Side		B Style			
					18	20	23	30
					19	21	25	36
			C: Hub Extension Both Sides		C Style			
	42	52	84					
	48	60						

<sup>!</sup>Alteration field only to be denoted if a deviation from standard is required. Please reference Alterations in engineering section, page 182.

TAPER-LOCK® bushing is not included with the sprocket. They are to be ordered separately. Please refer to the table below for general guidelines. Specific details are found in the Bushing Section of this catalog beginning on page 164.

TAPER-LOCK® Bushings	
Bushing #	Bore Range
1008	0.500 - 1.000"
1210	0.500 - 1.250"
1610	0.500 - 1.688"
2012	0.500 - 2.125"
2517	0.500 - 2.688"

# No. 40

## MULTI-STRAND TAPER-LOCK® SPROCKET DIMENSIONS

Tsubaki Stock Sprockets

All dimensions in inches unless noted.

Double Strand No. 40 TAPER-LOCK® Sprockets			Dimensional Data					
No. Teeth	Outside Diameter	Bushing #	MAX Bore*	LTB	Hub Diameter	Hub Type	Hub Style	Weight Lbs.
15	2.652	1008	1.000	0.875	1.266	A	S	0.50
16	2.814	1008	1.000	0.875	1.266	A	S	0.60
17	2.975	1008	1.000	0.875	1.266	A	S	0.70
18	3.135	1210	1.250	1.000	2.313	B	S	0.70
19	3.296	1210	1.250	1.000	2.500	B	S	0.90
20	3.457	1610	1.688	1.000	2.625	B	S	0.90
21	3.617	1610	1.688	1.000	2.750	B	S	1.00
23	3.938	1610	1.688	1.000	3.000	B	S	1.30
25	4.258	2012	2.125	1.250	3.406	B	S	1.60
30	5.057	2012	2.125	1.250	4.234	B	S	3.40
36	6.015	2012	2.125	1.250	5.156	B	S	5.90
42	6.972	2517	2.688	1.750	4.250	C	S	7.00
48	7.928	2517	2.688	1.750	4.250	C	S	9.60
52	8.566	2517	2.688	1.750	4.250	C	S	11.40
60	9.841	2517	2.688	1.750	4.250	C	S	15.40
84	13.663	2517	2.688	1.750	4.250	C	S	31.60

\* Please reference TAPER-LOCK® bushing dimension table on page 165 for specific information on MAX Bore and keyway data.

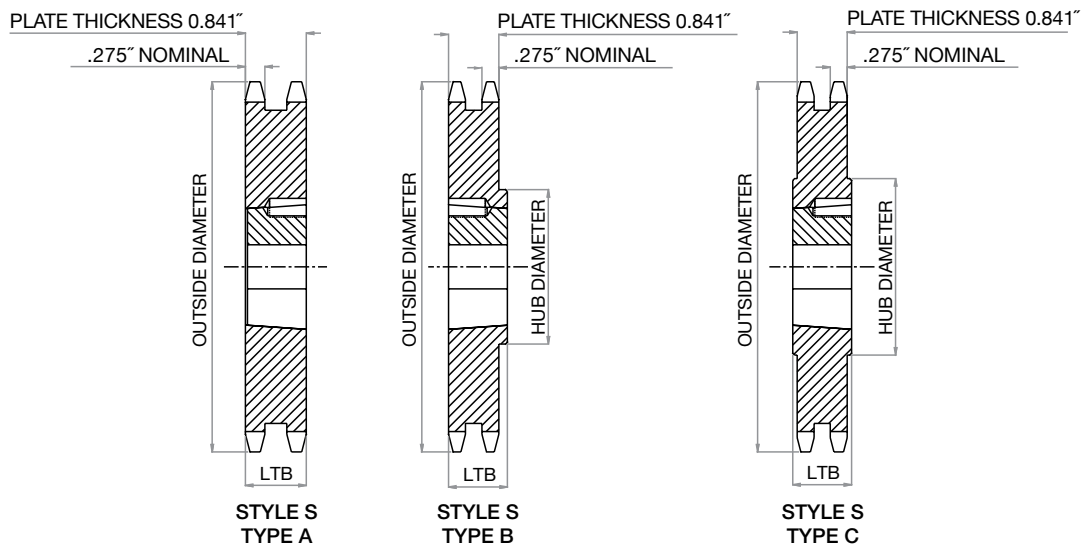



# HOW TO ORDER

TSUBAKI STOCK SPROCKETS



No. **50** 5/8" Pitch:  
PLAIN BORE

Chain Data	
Size	50
Pitch	5/8"
Inside Width	3/8"
Roller Diameter	0.400"
Nominal Tooth Width:	0.343"

How to Order Code: Example Model # for 50 Pitch Plain Bore Carbon Steel Sprockets

<b>A</b>	<b>50</b>	<b>A</b>	<b>37</b>
----------	-----------	----------	-----------

Altered <sup>!!</sup>	Chain Pitch in Inches	Hub Type	Number of Teeth					
			12	22	32	42	52	72
A: Alteration Required	50: 5/8" Pitch	A: No Hub Extension	13	23	33	43	53	80
			14	24	34	44	54	84
			15	25	35	45	55	96
			16	26	36	46	56	112
			17	27	37	47	57	
			18	28	38	48	58	
			19	29	39	49	59	
			20	30	40	50	60	
			21	31	41	51	70	
		B: Hub Extension One Side	8	19	30	41	52	80
			9	20	31	42	53	84
			10	21	32	43	54	96
			11	22	33	44	55	112
			12	23	34	45	56	
			13	24	35	46	57	
			14	25	36	47	58	
			15	26	37	48	59	
			16	27	38	49	60	
17	28	39	50	70				
18	29	40	51	72				

<sup>!!</sup> Alteration field only to be denoted if a deviation from standard is required. Please reference Alterations in engineering section, page 182.

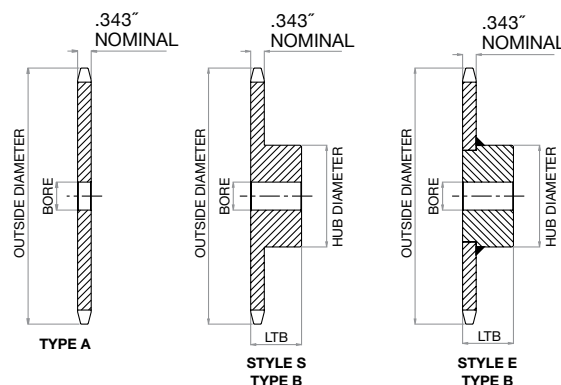

# No. 50

## PLAIN BORE SPROCKET DIMENSIONS

Tsubaki Stock Sprockets

All dimensions in inches unless noted.

No. 50 Plain Bore Sprocket Diameters				Type "A" Plain Bore		Type "B" Plain Bore					
No. Teeth	Outside Diameter	Pitch Diameter	Caliper Diameter	Plain Bore	Wt. Lbs.	Plain Bore	MAX Bore *	Hub Dia.	LTB	Hub Style	Wt. Lbs.
8	1.880	1.633	1.233	NS	NS	0.625	0.625	1.125 "	1.000	S	0.25
9	2.090	1.828	1.400	NS	NS	0.625	0.750	1.375 "	1.000	S	0.36
10	2.300	2.023	1.623	NS	NS	0.625	0.875	1.313 "	1.000	S	0.48
11	2.500	2.219	1.796	NS	NS	0.625	1.000	1.750 "	1.000	S	0.64
12	2.710	2.415	2.015	0.625	0.34	0.625	1.250	1.984 "	1.000	S	0.83
13	2.910	2.612	2.193	0.625	0.42	0.625	1.313	1.875	1.000	S	0.88
14	3.110	2.809	2.409	0.625	0.50	0.625	1.438	2.125	1.000	S	1.13
15	3.320	3.006	2.590	0.625	0.54	0.625	1.500	2.375	1.000	S	1.34
16	3.520	3.204	2.804	0.625	0.68	0.625	1.750	2.500	1.000	S	1.51
17	3.720	3.401	2.987	0.625	0.76	0.625	1.875	2.688	1.000	S	1.74
18	3.920	3.599	3.199	0.625	0.86	0.625	1.875	2.875	1.000	S	2.00
19	4.120	3.798	3.384	0.625	0.94	0.625	2.000	3.000	1.000	S	2.22
20	4.320	3.995	3.595	0.750	1.06	0.750	2.000	3.000	1.000	S	2.23
21	4.520	4.194	3.782	0.750	1.12	0.750	2.000	3.000	1.000	E	2.40
22	4.720	4.392	3.992	0.750	1.30	0.750	2.000	3.000	1.000	E	2.56
23	4.920	4.590	4.179	0.750	1.44	0.750	2.000	3.000	1.000	E	2.66
24	5.120	4.788	4.388	0.719	1.50	0.750	2.000	3.000	1.250	E	3.30
25	5.320	4.987	4.577	0.719	1.62	0.750	2.000	3.000	1.250	E	3.40
26	5.520	5.185	4.785	0.719	1.72	0.750	2.000	3.000	1.250	E	3.44
27	5.720	5.384	4.975	0.719	1.96	0.750	2.000	3.000	1.250	E	3.74
28	5.920	5.582	5.182	0.719	2.04	0.750	2.000	3.000	1.250	E	3.80
29	6.120	5.781	5.371	0.719	2.36	0.750	2.000	3.000	1.250	E	4.06
30	6.320	5.979	5.579	0.719	2.54	0.750	2.250	3.250	1.250	E	4.56
31	6.520	6.178	5.770	0.719	2.72	0.750	2.250	3.250	1.250	E	4.74
32	6.720	6.376	5.976	0.719	2.80	0.750	2.250	3.250	1.250	E	4.96
33	6.920	6.575	6.168	0.719	3.14	0.750	2.250	3.250	1.250	E	5.20
34	7.120	6.774	6.374	0.719	3.20	0.750	2.250	3.250	1.250	E	5.14
35	7.320	6.973	6.565	0.719	3.34	0.750	2.250	3.250	1.250	E	5.44
36	7.520	7.171	6.771	0.719	3.82	0.750	2.250	3.250	1.250	E	5.64
37	7.720	7.370	6.963	0.719	3.98	0.750	2.250	3.250	1.250	E	5.90
38	7.920	7.569	7.169	0.719	4.14	0.750	2.250	3.250	1.250	E	6.08
39	8.120	7.768	7.361	0.719	4.42	0.750	2.250	3.250	1.250	E	6.30
40	8.320	7.966	7.566	0.719	4.46	0.750	2.250	3.250	1.250	E	6.50
41	8.520	8.165	7.759	0.719	4.86	0.750	2.250	3.250	1.250	E	6.64
42	8.720	8.364	7.964	0.719	4.98	0.750	2.250	3.250	1.250	E	6.96
43	8.910	8.563	8.157	0.719	5.24	0.750	2.250	3.250	1.250	E	7.06
44	9.110	8.761	8.361	0.719	5.42	0.750	2.250	3.250	1.250	E	7.58
45	9.310	8.960	8.554	0.719	5.92	0.750	2.500	3.750	1.250	E	8.58
46	9.510	9.159	8.759	0.938	6.42	1.000	2.500	3.750	1.250	E	8.22
47	9.710	9.358	8.952	0.938	6.50	1.000	2.500	3.750	1.250	E	8.48
48	9.910	9.556	9.156	0.938	6.58	1.000	2.500	3.750	1.250	E	9.28
49	10.110	9.755	9.350	0.938	7.06	1.000	2.500	3.750	1.250	E	9.22
50	10.310	9.954	9.554	0.938	7.10	1.000	2.500	3.750	1.250	E	9.88
51	10.510	10.153	9.748	0.938	7.32	1.000	2.500	3.750	1.250	E	9.70
52	10.710	10.351	9.951	0.938	7.98	1.000	2.500	3.750	1.250	E	10.24
53	10.910	10.550	10.146	0.938	8.08	1.000	2.500	3.750	1.250	E	10.48
54	11.110	10.749	10.349	0.938	8.30	1.000	2.500	3.750	1.250	E	11.00
55	11.310	10.948	10.543	0.938	8.56	1.000	2.500	3.750	1.250	E	10.93
56	11.500	11.147	10.747	0.938	8.90	1.000	2.500	3.750	1.250	E	11.50
57	11.700	11.346	10.941	0.938	9.38	1.000	2.500	3.750	1.250	E	12.00
58	11.900	11.544	11.144	0.938	10.30	1.000	2.500	3.750	1.250	E	11.82
59	12.100	11.743	11.339	0.938	10.50	1.000	2.500	3.750	1.250	E	12.32
60	12.300	11.942	11.542	0.938	10.80	1.000	2.500	3.750	1.250	E	13.00
70	14.290	13.931	13.531	0.938	14.00	1.000	2.500	3.750	1.750	E	18.16
72	14.690	14.329	13.929	0.938	15.24	1.000	2.500	3.750	1.750	E	19.48
80	16.280	15.919	15.519	0.938	21.00	1.000	2.750	4.250	1.750	E	24.74
84	17.080	16.715	16.315	0.938	22.08	1.000	2.750	4.250	1.750	E	25.50
96	19.470	19.102	18.702	0.938	27.40	1.000	2.750	4.250	1.750	E	32.92
112	22.650	22.284	21.884	0.938	37.70	1.000	2.750	4.250	1.750	E	42.00

\* Dimensions shown allow for standard keyway with set screw at 90 degrees

" Has recessed groove in hub for chain clearance

NS = Non Stock

# HOW TO ORDER

TSUBAKI STOCK SPROCKETS



## No. 50 5/8" Pitch: FINISHED BORE

Chain Data	
Size	50
Pitch	5/8"
Inside Width	3/8"
Roller Diameter	0.400"
Nominal Tooth Width:	0.343"

How to Order Code: Example Model # for 50 Pitch Finished Bore Carbon Steel Sprockets

<b>50</b>	<b>B</b>	<b>60</b>	<b>F -</b>	<b>1B</b>
-----------	----------	-----------	------------	-----------

Chain Pitch in Inches	Hub Type	Number of Teeth					Finished Bore	Hub Bore**		
		9	22	35	48	70				
50: 5/8" Pitch	B: Hub Extension One Side						F: Hub Extension Machined with keyway and two set screws	J	5/8"	(0.625")
								L	3/4"	(0.750")
								P	7/8"	(0.875")
								1	1"	(1.000")
								1B	1-1/8"	(1.125")
								1C	1-3/16"	(1.188")
								1D	1-1/4"	(1.250")
								1F	1-3/8"	(1.375")
								1G:	1-7/16"	(1.437")
								1H:	1-1/2"	(1.500")
								1J:	1-5/8"	(1.625")
								1L	1-3/4"	(1.750")
								1R	1-15/16"	(1.938")

\*\* Hub bore size should be selected from dimensional table on the following page. Bore sizes that are not listed for a given number of sprocket teeth may be available per request as Altered.

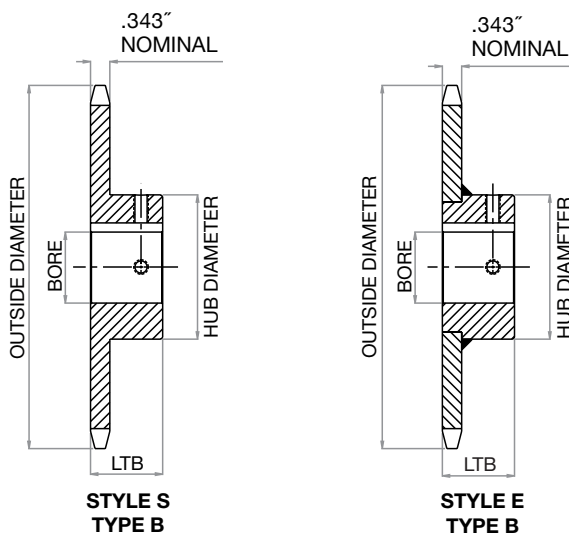

# No. 50

## FINISHED BORE SPROCKET DIMENSIONS

Tsubaki Stock Sprockets

All dimensions in inches unless noted.

No. 50 Finished Bore Sprocket Diameters				Type "F" Bored to Shaft Size (includes standard keyway and two set screws)												
No. Teeth	Outside Dia.	Pitch Dia.	Caliper Dia.	.625"	.750"	.875"	1.000"	1.125"	1.188"	1.250"	1.375"	1.438"	1.500"	1.625"	1.750"	1.938"
9	2.090	1.828	1.400	.	.											
10	2.300	2.023	1.623	.	.	.	■									
11	2.500	2.219	1.796	.	.	.	.									
12	2.710	2.415	2.015	.	.	.	.	.	.	.						
13	2.910	2.612	2.193	.	.	.	.	.	.	.						
14	3.110	2.809	2.409	.	.	.	.	.	.	.						
15	3.320	3.006	2.590	.	.	.	.	.	.	.	.					
16	3.520	3.204	2.804	.	.	.	.	.	.	.	.	.	.	.		
17	3.720	3.401	2.987	.	.	.	.	.	.	.	.	.	.	.	.	
18	3.920	3.599	3.199	.	.	.	.	.	.	.	.	.	.	.	.	
19	4.120	3.798	3.384	.	.	.	.	.	.	.	.	.	.	.	.	
20	4.320	3.995	3.595		.	.	.	.	.	.	.	.	.	.	.	
21	4.520	4.194	3.782		.	.	.	.	.	.	.	.	.	.	.	
22	4.720	4.392	3.992		.	.	.	.	.	.	.	.	.	.	.	
23	4.920	4.590	4.179		.	.	.	.	.	.	.	.	.	.	.	
24	5.120	4.788	4.388		.	.	.	.	.	.	.	.	.	.	.	
25	5.320	4.987	4.577		.	.	.	.	.	.	.	.	.	.	.	
26	5.520	5.185	4.785		.	.	.	.	.	.	.	.	.	.	.	
27	5.720	5.384	4.975		.	.	.	.	.	.	.	.	.	.	.	
28	5.920	5.582	5.182		.	.	.	.	.	.	.	.	.	.	.	
29	6.120	5.781	5.371		.	.	.	.	.	.	.	.	.	.	.	
30	6.320	5.979	5.579		.	.	.	.	.	.	.	.	.	.	.	
31	6.520	6.178	5.770		.	.	.	.	.	.	.	.	.	.	.	.
32	6.720	6.376	5.976		.	.	.	.	.	.	.	.	.	.	.	.
33	6.920	6.575	6.168		.	.	.	.	.	.	.	.	.	.	.	.
34	7.120	6.774	6.374		.	.	.	.	.	.	.	.	.	.	.	.
35	7.320	6.937	6.565		.	.	.	.	.	.	.	.	.	.	.	.
36	7.520	7.171	6.771		.	.	.	.	.	.	.	.	.	.	.	.
37	7.720	7.370	6.963		.	.	.	.	.	.	.	.	.	.	.	.
38	7.920	7.569	7.169		.	.	.	.	.	.	.	.	.	.	.	.
39	8.120	7.768	7.361		.	.	.	.	.	.	.	.	.	.	.	.
40	8.320	7.966	7.566		.	.	.	.	.	.	.	.	.	.	.	.
41	8.520	8.165	7.759		.	.	.	.	.	.	.	.	.	.	.	.
42	8.720	8.364	7.964		.	.	.	.	.	.	.	.	.	.	.	.
43	8.910	8.563	8.157		.	.	.	.	.	.	.	.	.	.	.	.
44	9.110	8.761	8.361		.	.	.	.	.	.	.	.	.	.	.	.
45	9.310	8.960	8.554		.	.	.	.	.	.	.	.	.	.	.	.
46	9.510	9.159	8.759		.	.	.	.	.	.	.	.	.	.	.	.
47	9.710	9.358	8.952		.	.	.	.	.	.	.	.	.	.	.	.
48	9.910	9.556	9.156		.	.	.	.	.	.	.	.	.	.	.	.
49	10.110	9.755	9.350		.	.	.	.	.	.	.	.	.	.	.	.
50	10.310	9.954	9.554		.	.	.	.	.	.	.	.	.	.	.	.
51	10.510	10.153	9.748		.	.	.	.	.	.	.	.	.	.	.	.
52	10.710	10.351	9.951		.	.	.	.	.	.	.	.	.	.	.	.
53	10.910	10.550	10.146		.	.	.	.	.	.	.	.	.	.	.	.
54	11.110	10.749	10.349		.	.	.	.	.	.	.	.	.	.	.	.
55	11.310	10.948	10.543		.	.	.	.	.	.	.	.	.	.	.	.
56	11.500	11.147	10.747		.	.	.	.	.	.	.	.	.	.	.	.
57	11.700	11.346	10.941		.	.	.	.	.	.	.	.	.	.	.	.
58	11.900	11.544	11.144		.	.	.	.	.	.	.	.	.	.	.	.
59	12.100	11.743	11.339		.	.	.	.	.	.	.	.	.	.	.	.
60	12.300	11.942	11.542		.	.	.	.	.	.	.	.	.	.	.	.
70	14.290	13.931	13.531		.	.	.	.	.	.	.	.	.	.	.	.
72	14.690	14.329	13.929		.	.	.	.	.	.	.	.	.	.	.	.
80	16.280	15.919	15.519		.	.	.	.	.	.	.	.	.	.	.	.
84	17.080	16.715	16.315		.	.	.	.	.	.	.	.	.	.	.	.
96	19.470	19.102	18.702		.	.	.	.	.	.	.	.	.	.	.	.
112	22.650	22.284	21.884		.	.	.	.	.	.	.	.	.	.	.	.

• Denotes stocking item

■ Indicates set screw at 90 degrees and 180 degrees from keyway

# HOW TO ORDER

TSUBAKI STOCK SPROCKETS



## No. 50 5/8" Pitch: STAINLESS STEEL PLAIN BORE

Chain Data	
Size	50SS
Pitch	5/8"
Inside Width	3/8"
Roller Diameter	0.400"
Nominal Tooth Width:	0.343"

How to Order Code: Example Model # for 50 Pitch Plain Bore Stainless Steel Sprockets

<b>A</b>	<b>50</b>	<b>B</b>	<b>25</b>					<b>SS</b>
Altered <sup>#</sup>	Chain Pitch in Inches	Hub Type:	Number of Teeth					Material
A: Alteration Required	50: 5/8" Pitch	B: Hub Extension One Side	10	15	20	25	40	SS: 304 Stainless Steel Construction
			11	16	21	26	45	
			12	17	22	28	60	
			13	18	23	30		
			14	19	24	35		

<sup>#</sup> Alteration field only to be denoted if a deviation from standard is required. Please reference Alterations in engineering section, page 182.

All dimensions in inches unless noted.

No. 50 Stainless Steel Sprocket Diameters				Type "B" Plain Bore					
No. Teeth	Outside Diameter	Pitch Diameter	Caliper Diameter	Plain Bore	MAX Bore *	Hub Diameter	LTB	Hub Style	Wt. Lbs.
10	2.300	2.023	1.623	0.625	0.875	1.563 "	1.000	S	0.50
11	2.500	2.219	1.796	0.625	1.000	1.750 "	1.000	S	0.60
12	2.710	2.415	2.015	0.625	1.250	1.984 "	1.000	S	0.70
13	2.910	2.612	2.193	0.625	1.313	1.875	1.000	S	0.80
14	3.110	2.809	2.409	0.625	1.438	2.125	1.000	S	1.00
15	3.320	3.006	2.590	0.625	1.500	2.375	1.000	S	1.30
16	3.520	3.204	2.804	0.625	1.750	2.500	1.000	S	1.50
17	3.720	3.401	2.987	0.625	1.875	2.688	1.000	S	1.80
18	3.920	3.599	3.199	0.625	1.875	2.875	1.000	S	2.00
19	4.120	3.798	3.384	0.625	1.750	2.500	1.000	S	2.30
20	4.320	3.995	3.595	0.750	1.750	2.500	1.000	S	2.50
21	4.520	4.194	3.782	0.750	2.000	3.000	1.000	D	2.70
22	4.720	4.392	3.992	0.750	2.000	3.000	1.000	D	3.30
23	4.920	4.590	4.179	0.750	2.000	3.000	1.000	D	3.80
24	5.120	4.788	4.388	0.750	2.000	3.000	1.250	D	4.10
25	5.320	4.987	4.577	0.750	2.000	3.000	1.250	D	4.30
26	5.520	5.185	4.785	0.750	2.000	3.000	1.250	D	4.60
28	5.920	5.582	5.182	0.750	2.000	3.000	1.250	D	5.00
30	6.320	5.979	5.579	0.750	2.250	3.250	1.250	D	5.20
35	7.320	6.973	6.565	0.750	2.250	3.250	1.250	D	6.50
40	8.320	7.966	7.566	0.750	2.250	3.250	1.250	D	7.80
45	9.310	8.960	8.554	0.750	2.500	3.750	1.250	D	8.50
60	12.300	11.942	11.542	1.000	2.500	3.750	1.250	D	14.00

\* Dimensions shown allow for standard keyway with set screw at 90 degrees

" Has recessed groove in hub for chain clearance

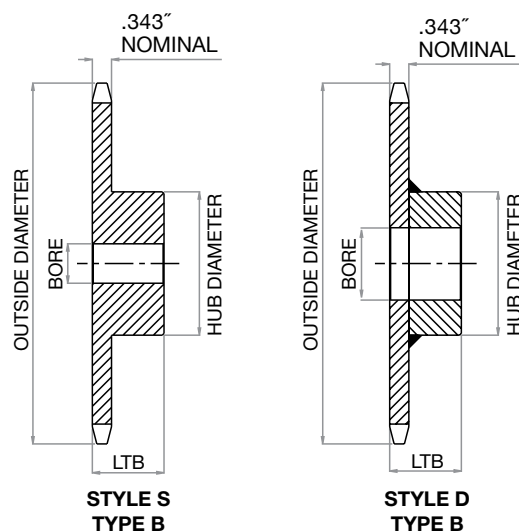

# HOW TO ORDER

TSUBAKI STOCK SPROCKETS



## No. 50 5/8" Pitch: MULTI-STRAND

Chain Data	
Size	50-2, 50-3
Pitch	5/8"
Inside Width	3/8"
Roller Diameter	0.400"
Nominal Tooth Width:	0.332"

How to Order Code: Example Model # for 50 Pitch Multi-Strand Carbon Steel Sprockets

<b>A</b>	<b>D</b>	<b>50</b>	<b>B</b>	<b>18</b>				
Altered <sup>1</sup>	Multi	Chain Pitch in Inches	Hub Type	Number of Teeth				
A: Alteration Required	D: Double Strand	50: 5/8" Pitch	B: Hub Extension One Side	Double Strand				
	T: Triple Strand			11	18	25	42	84
				12	19	26	45	96
				13	20	30	48	112
				14	21	32	52	
				15	22	35	54	
				16	23	36	60	
				17	24	40	72	
				Triple Strand				
				11	15	19	23	30
				12	16	20	24	35
				13	17	21	25	36
				14	18	22	26	

<sup>1</sup> Alteration field only to be denoted if a deviation from standard is required. Please reference Alterations in engineering section, page 182.

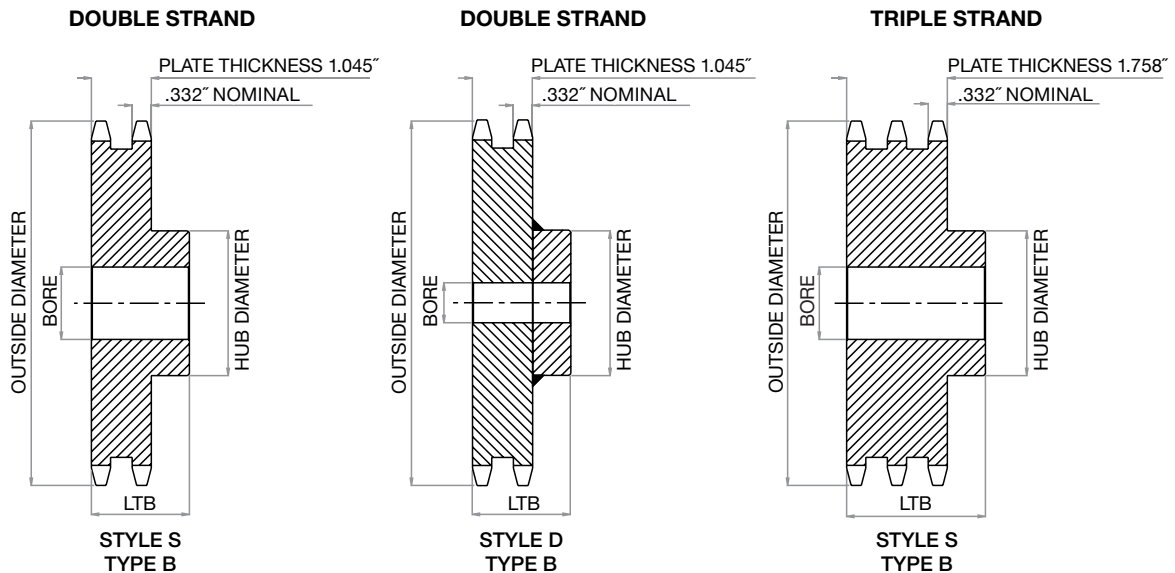

# No. 50

## MULTI-STRAND SPROCKET DIMENSIONS

Tsubaki Stock Sprockets

All dimensions in inches unless noted.

No. 50 Multi-Strand Sprocket Dia.			Dimensional Data: Double Strand Sprockets				
No. Teeth	Outside Dia.	Plain Bore	Hub Diameter	LTB	MAX Bore*	Hub Style	Wt. Lbs.
11	2.500	0.625	1.469	1.750	0.938	S	0.96
12	2.710	0.625	1.688	1.750	1.125	S	1.25
13	2.910	0.625	1.875	1.750	1.313	S	1.56
14	3.110	0.625	2.063	1.750	1.375	S	1.86
15	3.320	0.750	2.313	1.750	1.500	S	2.22
16	3.520	0.750	2.500	1.750	1.750	S	2.62
17	3.720	0.750	2.688	1.750	1.875	S	3.04
18	3.920	0.750	2.938	1.750	1.938	S	3.58
19	4.120	1.000	3.125	1.750	2.125	S	3.90
20	4.320	1.000	3.250	1.750	2.250	S	4.25
21	4.520	1.000	3.500	1.750	2.375	S	4.90
22	4.720	1.000	3.563	1.875	2.375	S	5.58
23	4.920	1.000	3.625	1.875	2.500	S	6.10
24	5.120	1.000	3.625	1.875	2.500	S	6.50
25	5.320	1.000	3.625	1.875	2.500	S	6.94
26	5.520	1.000	3.750	1.875	2.500	S	7.54
30	6.320	1.000	3.750	1.875	2.500	S	9.40
32	6.720	1.000	3.750	1.875	2.500	S	10.46
35	7.320	1.000	3.750	1.875	2.500	S	12.28
36	7.520	1.188	4.000	2.125	2.750	S	13.94
40	8.320	1.188	4.000	2.125	2.750	S	16.54
42	8.720	1.188	4.000	2.125	2.750	S	17.92
45	9.310	1.188	4.000	2.125	2.750	S	20.30
48	9.910	1.188	4.250	2.375	2.750	S	24.08
52	10.710	1.188	4.250	2.375	2.750	D	27.42
54	11.110	1.188	4.250	2.375	2.750	D	29.16
60	12.300	1.313	4.500	2.375	3.000	D	35.88
72	14.690	1.313	4.500	2.375	3.000	D	50.22
84	17.080	1.313	4.500	2.375	3.000	D	51.64
96	19.470	1.313	4.500	2.375	3.000	D	67.42
112	22.650	1.313	5.250	2.375	3.313	D	90.22

\* Dimensions shown allow for standard keyway with set screw at 90 degrees

All dimensions in inches unless noted.

No. 50 Multi-Strand Sprocket Dia.			Dimensional Data: Triple Strand Sprockets				
No. Teeth	Outside Dia.	Plain Bore	Hub Diameter	LTB	MAX Bore*	Hub Style	Wt. Lbs.
11	2.500	0.625	1.469	2.500	0.938	S	1.42
12	2.710	0.625	1.688	2.500	1.125	S	1.84
13	2.910	0.625	1.875	2.500	1.313	S	2.28
14	3.110	0.625	2.063	2.500	1.375	S	2.72
15	3.320	0.750	2.313	2.500	1.500	S	3.24
16	3.520	0.750	2.500	2.500	1.750	S	3.75
17	3.720	0.750	2.688	2.500	1.875	S	4.38
18	3.920	0.750	2.938	2.500	1.938	S	5.10
19	4.120	1.000	3.125	2.500	2.125	S	5.60
20	4.320	1.000	3.250	2.625	2.250	S	6.42
21	4.520	1.000	3.500	2.625	2.375	S	7.42
22	4.720	1.000	3.563	2.625	2.375	S	7.92
23	4.920	1.000	3.625	2.625	2.500	S	8.80
24	5.120	1.000	3.625	2.625	2.500	S	9.42
25	5.320	1.000	3.625	2.625	2.500	S	10.16
26	5.520	1.000	3.750	2.625	2.500	S	11.02
30	6.320	1.000	3.750	2.625	2.500	S	14.24
35	7.320	1.000	3.750	2.625	2.500	S	18.96
36	7.520	1.188	4.000	2.750	2.750	S	20.60

\* Dimensions shown allow for standard keyway with set screw at 90 degrees



# HOW TO ORDER

TSUBAKI STOCK SPROCKETS



## No. 50 5/8" Pitch: DOUBLE SINGLE

Chain Data	
Size	50
Pitch	5/8"
Inside Width	3/8"
Roller Diameter	0.400"
Nominal Tooth Width:	0.343"

How to Order Code: Example Model # for 50 Pitch Double Single Carbon Steel Sprockets

<b>A</b>	<b>DS</b>	<b>50</b>	<b>A</b>	<b>23</b>										
Altered <sup>!!</sup>	Multi	Chain Pitch in Inches	Hub Type	Number of Teeth										
A: Alteration Required	DS: Double Single	50: 5/8" Pitch	A: No Hub Extension	<table border="1"> <tr> <td>15</td> <td>17</td> <td>19</td> <td>21</td> <td>23</td> </tr> <tr> <td>16</td> <td>18</td> <td>20</td> <td>22</td> <td>24</td> </tr> </table>	15	17	19	21	23	16	18	20	22	24
15	17	19	21	23										
16	18	20	22	24										

<sup>!!</sup>Alteration field only to be denoted if a deviation from standard is required. Please reference Alterations in engineering section, page 182.

How to Order Code: Example Model # for 50 Pitch Double Single TAPER-LOCK® Carbon Steel Sprockets

<b>A</b>	<b>DS</b>	<b>50</b>	<b>A</b>	<b>TL</b>	<b>24</b>										
Altered <sup>!!</sup>	Multi	Chain Pitch in Inches	Hub Type	TAPER-LOCK®	Number of Teeth										
A: Alteration Required	DS: Double Single	50: 5/8" Pitch	A: No Hub Extension	TAPER-LOCK® hub with set screws	<table border="1"> <tr> <td>17</td> <td>19</td> <td>23</td> <td></td> <td></td> </tr> <tr> <td>18</td> <td>21</td> <td>24</td> <td></td> <td></td> </tr> </table>	17	19	23			18	21	24		
17	19	23													
18	21	24													

<sup>!!</sup>Alteration field only to be denoted if a deviation from standard is required. Please reference Alterations in engineering section, page 182.

TAPER-LOCK® bushing is not included with the sprocket. They are to be ordered separately. Please refer to the table below for general guidelines. Specific details are found in the Bushing Section of this catalog beginning on page 164.

TAPER-LOCK® Bushings	
Bushing #	Bore Range
1610	0.500 - 1.688"
2012	0.500 - 2.125"

# No. 50

## DOUBLE SINGLE SPROCKET DIMENSIONS

Tsubaki Stock Sprockets

All dimensions in inches unless noted.

No. 50 Double Single Sprocket Dia.			Dimensional Data: Double Single Sprockets				
No. Teeth	Outside Diameters	Plain Bore	LTB	C	D	MAX Bore *	Weight Lbs.
15	3.320	0.625	1.656	1.313	2.375	1.500	2.10
16	3.520	0.625	1.656	1.313	2.500	1.688	2.40
17	3.720	0.625	1.656	1.313	2.688	1.750	2.90
18	3.920	0.625	1.656	1.313	2.891	1.875	3.30
19	4.120	0.625	1.656	1.313	3.078	2.063	3.70
20	4.320	0.625	1.656	1.313	3.281	2.250	4.20
21	4.520	0.625	1.656	1.313	3.484	2.250	4.80
22	4.720	0.625	1.656	1.313	3.688	2.438	5.30
23	4.920	0.625	1.656	1.313	3.891	2.625	5.80
24	5.120	0.625	1.656	1.313	4.078	2.750	6.30

\* Dimensions shown allow for standard keyway with set screw at 90 degrees

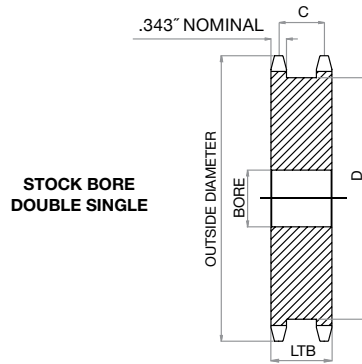

All dimensions in inches unless noted.

No. 50 Double Single TAPER-LOCK® Sprocket Dia.			Dimensional Data: Double Single TAPER-LOCK® Sprockets				
No. Teeth	Outside Diameters	Bushing #	LTB	C	D	MAX Bore *	Weight Lbs.
17	3.720	1610	1.656	1.313	2.688	1.688	1.80
18	3.920	1610	1.656	1.313	2.891	1.688	2.20
19	4.120	1610	1.656	1.313	3.078	1.688	2.70
21	4.520	2012	1.656	1.313	3.469	2.125	3.30
23	4.920	2012	1.656	1.313	3.891	2.125	3.70
24	5.120	2012	1.656	1.313	4.078	2.125	4.10

\* Please reference TAPER-LOCK® bushing dimension table on page 165 for specific information on MAX Bore and keyway data.

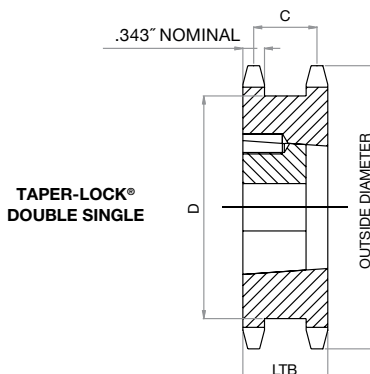

# HOW TO ORDER

TSUBAKI STOCK SPROCKETS



## No. 50 5/8" Pitch: TAPER-LOCK®

Chain Data	
Size	50
Pitch	5/8"
Inside Width	3/8"
Roller Diameter	0.400"
Nominal Tooth Width:	0.343"

How to Order Code: Example Model # for 50 Pitch TAPER-LOCK® Carbon Steel Sprockets

<b>A</b>	<b>50</b>	<b>B</b>	<b>TL</b>	<b>42</b>				
Altered <sup>‡</sup>	Chain Pitch in Inches	Hub Type	TAPER-LOCK®	Number of Teeth				
A: Alteration Required	50: 5/8" Pitch	B: Hub Extension One Side	TAPER-LOCK® hub with set screws	12	19	26	40	72
				13	20	27	42	80
				14	21	28	45	84
				15	22	30	48	96
				16	23	32	54	112
				17	24	35	60	
				18	25	36	70	

<sup>‡</sup>Alteration field only to be denoted if a deviation from standard is required. Please reference Alterations in engineering section, page 182.

TAPER-LOCK® bushing is not included with the sprocket. They are to be ordered separately. Please refer to the table below for general guidelines. Specific details are found in the Bushing Section of this catalog beginning on page 164.

TAPER-LOCK® Bushings	
Bushing #	Bore Range
1008	0.500 - 1.000"
1210	0.500 - 1.250"
1610	0.500 - 1.688"
2012	0.500 - 2.125"
2517	0.500 - 2.688"

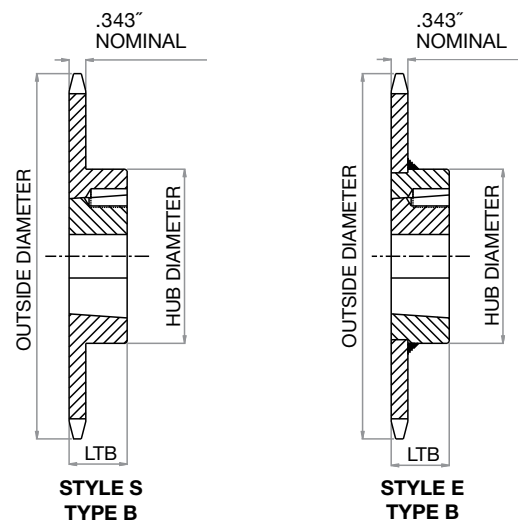

# No. 50

## TAPER LOCK® SPROCKET DIMENSIONS

Tsubaki Stock Sprockets

All dimensions in inches unless noted.

No. 50 TAPER-LOCK® Sprocket Dia.			Dimensional Data TAPER-LOCK® Sprockets				
No. Teeth	Outside Diameter	Bushing #	MAX Bore*	LTB	Hub Diameter	Hub Style	Weight Lbs.
12	2.710	1008	1.000	0.875	1.938 **	S	0.50
13	2.910	1008	1.000	0.875	1.813	S	0.50
14	3.110	1008	1.000	0.875	1.938	S	0.60
15	3.320	1210	1.250	1.000	2.469 **	S	0.70
16	3.520	1610	1.688	1.000	2.781 **	S	0.70
17	3.720	1610	1.688	1.000	2.781 **	S	0.80
18	3.920	1610	1.688	1.000	2.781	S	0.90
19	4.120	1610	1.688	1.000	3.000	S	1.30
20	4.320	1610	1.688	1.000	3.250	S	1.60
21	4.520	1610	1.688	1.000	3.500	S	1.60
22	4.720	1610	1.688	1.000	3.500	S	1.60
23	4.920	2012	2.125	1.250	3.875	S	2.00
24	5.120	2012	2.125	1.250	4.000	S	2.20
25	5.320	2012	2.125	1.250	4.000	S	2.40
26	5.520	2012	2.125	1.250	4.000	E	2.50
27	5.720	2012	2.125	1.250	4.000	E	2.60
28	5.920	2012	2.125	1.250	4.000	E	2.80
30	6.320	2012	2.125	1.250	3.563	E	3.20
32	6.720	2012	2.125	1.250	3.563	E	3.60
35	7.320	2012	2.125	1.250	3.563	E	4.20
36	7.520	2012	2.125	1.250	3.563	E	4.30
40	8.320	2012	2.125	1.250	3.563	E	5.20
42	8.720	2012	2.125	1.250	3.563	E	5.90
45	9.310	2012	2.125	1.250	3.563	E	6.50
48	9.910	2012	2.125	1.250	3.563	E	7.30
54	11.110	2012	2.125	1.250	3.563	E	9.00
60	12.300	2012	2.125	1.250	3.563	E	10.80
70	14.290	2517	2.688	1.750	4.250	E	14.00
72	14.690	2517	2.688	1.750	4.250	E	15.50
80	16.280	2517	2.688	1.750	4.250	E	19.50
84	17.080	2517	2.688	1.750	4.250	E	22.50
96	19.470	2517	2.688	1.750	4.250	E	29.00
112	22.650	2517	2.688	1.750	4.250	E	38.70

\* Please reference TAPER-LOCK® bushing dimension table on page 165 for specific information on MAX Bore and keyway data.

\*\* Has recessed groove in hub for chain clearance

# HOW TO ORDER

TSUBAKI STOCK SPROCKETS



No.  
**50**

**5/8" Pitch:  
MULTI-STRAND TAPER-LOCK®**

Chain Data	
Size	50-2
Pitch	5/8"
Inside Width	3/8"
Roller Diameter	0.400"
Nominal Tooth Width:	0.332"

How to Order Code: Example Model # for 50 Pitch Multi-Strand TAPER-LOCK® Carbon Steel Sprockets

<b>A</b>	<b>D</b>	<b>50</b>	<b>C</b>	<b>TL</b>	<b>42</b>
----------	----------	-----------	----------	-----------	-----------

Altered <sup>†</sup>	Multi-Strand	Chain Pitch in Inches	Hub Type	TAPER-LOCK®	Number of Teeth				
A: Alteration Required	D: Double Strand	50: 5/8" Pitch	A: No Hub Extension	TAPER-LOCK® hub with set screws	A Style				
					14	16	18		
			15		17	19			
			B Style						
			20		25				
			21		30				
			C Style						
			36		48	60	84		
			42		52	60			

<sup>†</sup>Alteration field only to be denoted if a deviation from standard is required. Please reference Alterations in engineering section, page 182.

TAPER-LOCK® bushing is not included with the sprocket. They are to be ordered separately. Please refer to the table below for general guidelines. Specific details are found in the Bushing Section of this catalog beginning on page 164.

TAPER-LOCK® Bushings	
Bushing #	Bore Range
1008	0.500 - 1.000"
1210	0.500 - 1.250"
1610	0.500 - 1.688"
2012	0.500 - 2.125"
2517	0.500 - 2.688"

# No. 50

## MULTI-STRAND TAPER-LOCK® SPROCKET DIMENSIONS

Tsubaki Stock Sprockets

All dimensions in inches unless noted.

No. 50 Multi-Strand TAPER-LOCK® Sprocket Dia.			Dimensional Data Double Strand TAPER-LOCK® Sprockets					
No. Teeth	Outside Diameter	Bushing #	MAX Bore*	LTB	Hub Diameter	Hub Type	Hub Style	Weight Lbs.
14	3.110	1008	1.000	0.875	N/A	A	S	0.80
15	3.320	1210	1.250	1.000	N/A	A	S	0.90
16	3.520	1210	1.250	1.000	N/A	A	S	1.10
17	3.720	1610	1.688	1.000	N/A	A	S	1.10
18	3.920	1610	1.688	1.000	N/A	A	S	1.30
19	4.120	1610	1.688	1.000	N/A	A	S	1.60
20	4.320	2012	2.125	1.250	3.250	B	S	1.50
21	4.520	2012	2.125	1.250	3.500	B	S	1.90
25	5.320	2012	2.125	1.250	4.281	B	S	3.80
30	6.320	2517	2.688	1.750	5.281	B	S	7.50
36	7.520	2517	2.688	1.750	4.250	C	S	9.40
42	8.720	2517	2.688	1.750	4.250	C	S	13.40
48	9.910	2517	2.688	1.750	4.250	C	S	18.60
52	10.710	2517	2.688	1.750	4.375	C	S	22.20
60	12.300	2517	2.688	1.750	4.375	C	S	30.30
84	17.080	2517	2.688	1.750	4.375	C	S	45.30

\* Please reference TAPER-LOCK® bushing dimension table on page 165 for specific information on MAX Bore and keyway data.

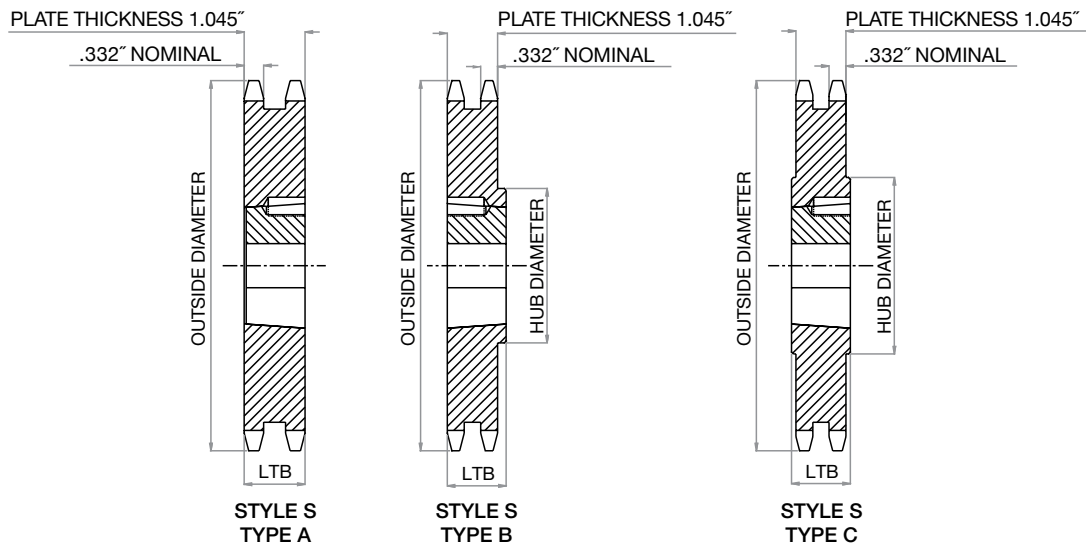

# HOW TO ORDER

TSUBAKI STOCK SPROCKETS



No.  
**50** 5/8" Pitch: QD®

Chain Data	
Size	50
Pitch	5/8"
Inside Width	3/8"
Roller Diameter	0.400"
Nominal Tooth Width:	0.343"

How to Order Code: Example Model # for 50 Pitch QD® Carbon Steel Sprockets

<b>A</b>	<b>50</b>	<b>SH</b>	<b>19</b>
----------	-----------	-----------	-----------

Altered <sup>!!</sup>	Chain Pitch in Inches	QD® Hub Type	Number of Teeth				
			12	14	16		
A: Alteration Required	50: 5/8" Pitch	JA: QD® Hub 12 - 16 tooth sprocket	12	14	16		
			13	15			
		SH: QD® Hub 17 - 19 tooth sprocket	17	19			
			18				
		SDS: QD® Hub 20 - 48 tooth sprocket	20	24	28	36	48
			21	25	30	40	
			22	26	32	42	
			23	27	35	45	
		SK: QD® Hub 54 - 72 tooth sprocket	54	70			
			60	72			
		SF: QD® Hub 80 - 112 tooth sprocket	80	96			
			84	112			

<sup>!!</sup>Alteration field only to be denoted if a deviation from standard is required. Please reference Alterations in engineering section, page 182.

QD® bushing is not included with the sprocket. They are to be ordered separately. Please refer to the table below for general guidelines. Specific details are found in the Bushing Section of this catalog beginning on page 170.

QD® Bushings	
Bushing #	Bore Range
JA	0.500 - 1.250"
SH	0.500 - 1.688"
SDS	0.500 - 2.000"
SK	0.500 - 2.625"
SF	0.500 - 2.938"

# No. 50

## QD® SPROCKET DIMENSIONS

Tsubaki Stock Sprockets

All dimensions in inches unless noted.

No. 50 QD® Sprocket Dia.			Dimensional Data QD® Sprockets									
No. Teeth	Outside Dia.	QD® Bushing #	MAX Bore*	Hub Dia.	LTB	X	Y	L	F	Hub Type	Hub Style	Weight Lbs.
12	2.710	JA	1.250	1.922	0.625	1.125	1.125	0.656	2.063	B	S	0.34
13	2.910	JA	1.250	2.063	0.625	1.125	1.125	0.656	2.063	B	S	0.40
14	3.110	JA	1.250	2.125	0.625	1.125	1.125	0.656	2.063	B	S	0.52
15	3.320	JA	1.250	2.250	0.625	1.125	1.125	0.656	2.063	B	S	0.60
16	3.520	JA	1.250	2.250	0.625	1.125	1.125	0.656	2.063	B	S	0.68
17	3.720	SH	1.688	2.750	0.813	1.437	1.437	0.906	2.688	B	S	0.84
18	3.920	SH	1.688	2.875	0.813	1.437	1.437	0.906	2.688	B	S	1.04
19	4.120	SH	1.688	3.000	0.813	1.437	1.437	0.906	2.688	B	S	1.24
20	4.320	SDS	2.000	3.313	0.750	1.500	1.500	0.969	3.188	B	S	1.20
21	4.520	SDS	2.000	3.500	0.750	1.500	1.500	0.969	3.188	B	S	1.32
22	4.720	SDS	2.000	3.500	0.750	1.500	1.500	0.969	3.188	B	S	1.42
23	4.920	SDS	2.000	3.500	0.750	1.500	1.500	0.969	3.188	B	S	1.58
24	5.120	SDS	2.000	3.625	0.750	1.500	1.500	0.969	3.188	B	E	1.70
25	5.320	SDS	2.000	3.625	0.750	1.500	1.500	0.969	3.188	B	E	1.86
26	5.520	SDS	2.000	3.625	0.750	1.500	1.500	0.969	3.188	B	E	2.00
27	5.720	SDS	2.000	3.625	0.750	1.500	1.500	0.969	3.188	B	E	2.12
28	5.920	SDS	2.000	3.625	0.750	1.500	1.500	0.969	3.188	B	E	2.32
30	6.320	SDS	2.000	3.625	0.750	1.500	1.500	0.969	3.188	B	E	2.64
32	6.720	SDS	2.000	3.625	0.750	1.500	1.500	0.969	3.188	B	E	2.98
35	7.320	SDS	2.000	3.625	0.750	1.500	1.500	0.969	3.188	B	E	3.62
36	7.520	SDS	2.000	3.625	0.750	1.500	1.500	0.969	3.188	B	E	3.64
40	8.320	SDS	2.000	3.625	0.750	1.500	1.500	0.969	3.188	B	E	4.74
42	8.720	SDS	2.000	3.625	0.750	1.500	1.500	0.969	3.188	B	E	5.40
45	9.310	SDS	2.000	3.625	0.750	1.500	1.500	0.969	3.188	B	E	5.90
48	9.910	SDS	2.000	3.625	0.750	1.500	1.500	0.969	3.188	B	E	6.66
54	11.110	SK	2.625	3.625	1.250	2.125	2.125	1.531	3.875	B	E	9.68
60	12.300	SK	2.625	4.250	1.250	2.125	2.125	1.531	3.875	B	E	11.88
70	14.290	SK	2.625	4.250	1.250	2.125	2.125	1.531	3.875	B	E	15.52
72	14.690	SK	2.625	4.250	1.250	2.125	2.125	1.531	3.875	B	E	16.44
80	16.280	SF **	2.938	5.000	1.250	2.250	2.250	1.656	4.625	B	E	19.90
84	17.080	SF **	2.938	5.000	1.250	2.250	2.250	1.656	4.625	B	E	22.98
96	19.470	SF **	2.938	5.000	1.250	2.250	2.250	1.656	4.625	B	E	29.88
112	22.650	SF **	2.938	5.000	1.250	2.250	2.250	1.656	4.625	B	E	40.10

\* Please reference QD® bushing dimension table on page 171 for specific information on MAX Bore and keyway data.

\*\* = Max Bore with shallow key

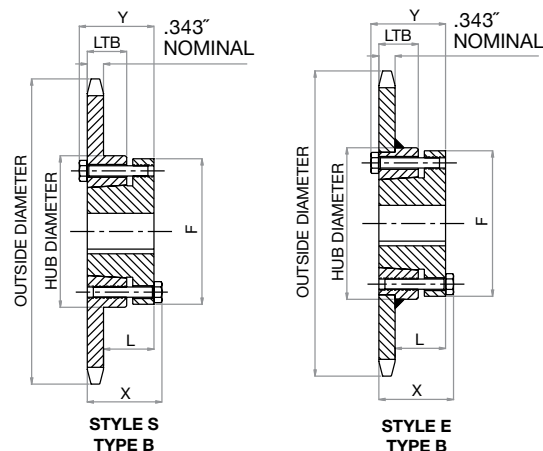



# HOW TO ORDER

TSUBAKI STOCK SPROCKETS



No. **60** 3/4" Pitch:  
PLAIN BORE

Chain Data	
Size	60
Pitch	3/4"
Inside Width	1/2"
Roller Diameter	0.469"
Nominal Tooth Width:	0.459"

How to Order Code: Example Model # for 60 Pitch Plain Bore Carbon Steel Sprockets

<b>A</b>	<b>60</b>	<b>A</b>	<b>37</b>
----------	-----------	----------	-----------

Altered <sup>¶</sup>	Chain Pitch in Inches	Hub Type	Number of Teeth					
			10	20	30	40	50	60
A: Alteration Required	60: 3/4" Pitch	A: No Hub Extension	11	21	31	41	51	70
			12	22	32	42	52	72
			13	23	33	43	53	80
			14	24	34	44	54	84
			15	25	35	45	55	96
			16	26	36	46	56	112
			17	27	37	47	57	
			18	28	38	48	58	
			19	29	39	49	59	
		B: Hub Extension One Side	8	19	30	42	53	84
			9	20	31	43	54	96
			10	21	32	44	55	112
			11	22	33	45	56	
			12	23	34	46	57	
			13	24	35	47	58	
			14	25	36	48	59	
			15	26	37	49	60	
			16	27	38	50	70	
17	28	39	51	72				
18	29	40	52	80				

<sup>¶</sup> Alteration field only to be denoted if a deviation from standard is required. Please reference Alterations in engineering section, page 182.

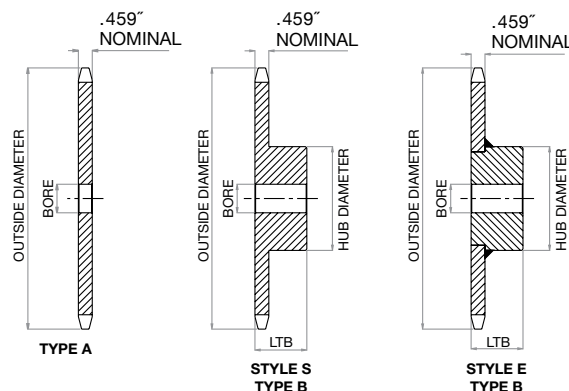

All dimensions in inches unless noted.

No. 60 Plain Bore Sprocket Dia.				Type "A" Plain Bore		Type "B" Plain Bore					
No. Teeth	Outside Dia.	Pitch Dia.	Caliper Dia.	Plain Bore	Wt. Lbs.	Plain Bore	MAX Bore *	Hub Dia.	LTB	Hub Style	Wt. Lbs.
8	2.260	1.959	1.491	NS	NS	0.625	0.625	1.469	1.250	S	0.54
9	2.510	2.193	1.691	NS	NS	0.750	0.875	1.563	1.250	S	0.64
10	2.760	2.427	1.958	0.750	0.44	0.750	1.125	1.938	1.250	S	0.99
11	3.000	2.663	2.166	0.750	0.54	0.750	1.313	2.063	1.250	S	1.15
12	3.250	2.898	2.429	0.750	0.68	0.750	1.375	2.375	1.250	S	1.47
13	3.490	3.134	2.642	0.750	0.80	0.750	1.500	2.344	1.250	S	1.66
14	3.740	3.371	2.902	0.750	0.94	0.750	1.750	2.563	1.250	S	2.00
15	3.980	3.608	3.119	0.750	1.08	0.750	1.875	2.875	1.250	S	2.51
16	4.220	3.845	3.375	0.750	1.24	0.750	2.000	3.063	1.250	S	2.81
17	4.460	4.082	3.595	0.750	1.44	0.750	2.250	3.250	1.250	S	3.22
18	4.700	4.319	3.850	0.750	1.62	0.750	2.375	3.500	1.250	E	3.72
19	4.950	4.557	4.072	0.750	1.84	0.750	2.375	3.500	1.250	E	3.92
20	5.190	4.794	4.325	0.750	2.12	0.750	2.625	3.875	1.250	E	4.63
21	5.430	5.033	4.549	0.750	2.28	0.750	2.750	4.000	1.250	E	5.00
22	5.670	5.270	4.801	0.750	2.48	0.750	2.750	4.000	1.250	E	5.25
23	5.910	5.508	5.026	0.750	2.68	0.750	2.750	4.000	1.250	E	5.48
24	6.150	5.746	5.277	0.719	3.00	0.750	2.750	4.000	1.250	E	5.78
25	6.390	5.984	5.503	0.719	3.34	0.750	2.750	4.000	1.250	E	6.13
26	6.630	6.222	5.753	0.719	3.54	0.750	2.750	4.000	1.250	E	6.38
27	6.870	6.461	5.980	0.719	3.96	0.750	2.750	4.000	1.250	E	6.72
28	7.110	6.698	6.229	0.719	4.14	0.750	2.750	4.000	1.250	E	6.88
29	7.350	6.937	6.458	0.719	4.40	0.750	2.750	4.000	1.250	E	7.28
30	7.590	7.175	6.706	0.719	4.78	0.750	2.750	4.000	1.250	E	7.58
31	7.830	7.413	6.935	0.719	5.24	0.750	2.750	4.000	1.250	E	7.72
32	8.070	7.652	7.183	0.719	5.52	0.750	2.750	4.000	1.250	E	8.26
33	8.300	7.890	7.412	0.938	5.86	1.000	2.750	4.000	1.250	E	8.42
34	8.540	8.129	7.660	0.938	6.16	1.000	2.750	4.000	1.250	E	8.80
35	8.780	8.367	7.889	0.938	6.78	1.000	2.750	4.000	1.250	E	9.04
36	9.020	8.606	8.137	0.938	6.82	1.000	2.750	4.000	1.250	E	9.60
37	9.260	8.844	8.367	0.938	7.52	1.000	2.750	4.000	1.250	E	10.24
38	9.500	9.083	8.614	0.938	7.84	1.000	2.750	4.250	1.250	E	10.84
39	9.740	9.321	8.844	0.938	8.28	1.000	2.750	4.250	1.250	E	11.36
40	9.980	9.560	9.091	0.938	8.56	1.000	2.750	4.250	1.250	E	11.50
41	10.220	9.798	9.321	0.938	9.10	1.000	2.750	4.250	1.250	E	12.14
42	10.460	10.037	9.568	0.938	9.74	1.000	2.750	4.250	1.250	E	12.74
43	10.700	10.275	9.799	0.938	9.84	1.000	2.750	4.250	1.250	E	13.00
44	10.940	10.514	10.045	0.938	10.76	0.938	2.750	4.250	1.250	E	13.88
45	11.180	10.752	10.276	0.938	11.08	0.938	2.750	4.250	1.250	E	13.98
46	11.420	10.991	10.522	0.938	11.50	0.938	2.750	4.250	1.250	E	14.60
47	11.650	11.229	10.754	0.938	12.32	0.938	2.750	4.250	1.250	E	15.00
48	11.890	11.468	10.999	0.938	12.42	0.938	2.750	4.250	1.250	E	15.82
49	12.130	11.706	11.231	0.938	12.92	0.938	2.750	4.250	1.250	E	15.90
50	12.370	11.945	11.476	0.938	13.98	0.938	2.750	4.250	1.250	E	16.98
51	12.610	12.183	11.708	0.938	14.58	0.938	2.750	4.250	1.250	E	17.66
52	12.850	12.422	11.953	0.938	14.60	0.938	2.750	4.250	1.250	E	17.93
53	13.090	12.660	12.186	0.938	15.84	0.938	2.750	4.250	1.250	E	17.99
54	13.330	12.889	12.430	0.938	15.92	0.938	2.750	4.250	1.750	E	21.60
55	13.570	13.137	12.663	1.250	16.96	1.250	2.750	4.250	1.750	E	21.14
56	13.810	13.376	12.907	1.250	17.60	1.250	2.750	4.250	1.750	E	21.88
57	14.040	13.615	13.140	1.250	17.62	1.250	2.750	4.250	1.750	E	22.25
58	14.280	13.853	13.384	1.250	19.00	1.250	2.750	4.250	1.750	E	22.80
59	14.520	14.092	13.618	1.250	19.20	1.250	2.750	4.250	1.750	E	23.86
60	14.760	14.330	13.861	1.250	20.02	1.250	2.750	4.250	1.750	E	25.22
70	17.150	16.717	16.248	1.250	27.20	1.250	2.750	4.250	1.750	E	31.98
72	17.630	17.195	16.726	1.250	28.90	1.250	2.750	4.250	1.750	E	34.18
80	19.540	19.103	18.634	1.250	40.18	1.250	2.750	4.250	2.000	E	41.88
84	20.490	20.058	19.589	1.250	45.50	1.250	3.250	4.750	2.000	E	46.46
96	23.360	22.922	22.453	1.250	52.02	1.250	3.750	5.500	2.250	E	63.08
112	27.180	26.741	26.272	1.250	70.80	1.250	3.750	5.500	2.250	E	81.78

\* Dimensions shown allow for standard keyway with set screw at 90 degrees

\*\* Has recessed groove in hub for chain clearance

NS = Non Stock

# HOW TO ORDER

TSUBAKI STOCK SPROCKETS



## No. 60 3/4" Pitch: FINISHED BORE

Chain Data	
Size	60
Pitch	3/4"
Inside Width	1/2"
Roller Diameter	0.469"
Nominal Tooth Width:	0.459"

How to Order Code: Example Model # for 60 Pitch Finished Bore Carbon Steel Sprockets

<b>60</b>	<b>B</b>	<b>36</b>	<b>F -</b>	<b>2</b>
-----------	----------	-----------	------------	----------

Chain Pitch in Inches	Hub Type	Number of Teeth					Finished Bore	Hub Bore**		
		9	21	33	45	57				
60: 3/4" Pitch	B: Hub Extension One Side						F: Hub Extension Machined with keyway and two set screws	J	5/8"	(0.625")
								L	3/4"	(0.750")
								P	7/8"	(0.875")
								1	1"	(1.000")
								1B	1-1/8"	(1.125")
								1C	1-3/16"	(1.188")
								1D	1-1/4"	(1.250")
								1F	1-3/8"	(1.375")
								1G:	1-7/16"	(1.438")
								1H:	1-1/2"	(1.500")
								1J	1-5/8"	(1.625")
								1L	1-3/4"	(1.750")
								1R	1-15/16"	(1.938")
								2	2"	(2.000")
					2C	2-3/16"	(2.188")			
					2G	2-7/16"	(2.438")			

\*\* Hub bore size should be selected from dimensional table on the following page. Bore sizes that are not listed for a given number of sprocket teeth may be available per request as Altered.

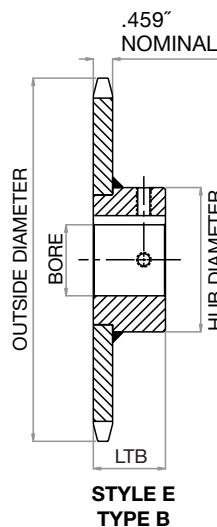
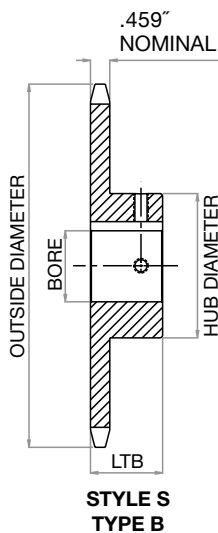

All dimensions in inches unless noted.

No. 60 Finished Bore Sprocket Dia.				Type "F" Bored to Shaft Size (includes standard keyway and two set screws)														
No. Teeth	Outside Dia.	Pitch Dia.	Caliper Dia.	.750"	.875"	1.000"	1.125"	1.188"	1.250"	1.375"	1.438"	1.500"	1.625"	1.750"	1.938"	2.000"	2.188"	2.438"
9	2.510	2.193	1.691	•	•	•												
10	2.760	2.427	1.958	•	•	•			■									
11	3.000	2.663	2.166	•	•	•			■									
12	3.250	2.898	2.429	•	•	•			■	•	■							
13	3.490	3.134	2.642	•	•	•			•	■	■							
14	3.740	3.371	2.902	•	•	•			•	■	■							
15	3.980	3.608	3.119	•	•	•			•	•	•			■				
16	4.220	3.845	3.375	•	•	•			•	•	•			•	■			
17	4.460	4.082	3.595			•			•	•	•			•	■			
18	4.700	4.319	3.850			•			•	•	•			•	•			
19	4.950	4.557	4.072			•			•	•	•			•	•			
20	5.190	4.794	4.325			•			•	•	•			•	•			
21	5.430	5.033	4.549			•			•	•	•			•	•			
22	5.670	5.270	4.801			•			•	•	•			•	•			
23	5.910	5.508	5.026			•			•	•	•			•	•			
24	6.150	5.746	5.277			•			•	•	•			•	•			
25	6.390	5.984	5.503			•			•	•	•			•	•			
26	6.630	6.222	5.753			•			•	•	•			•	•			
27	6.870	6.461	5.98			•			•	•	•			•	•			
28	7.110	6.698	6.229			•			•	•	•			•	•			
29	7.350	6.937	6.458			•			•	•	•			•	•			
30	7.590	7.175	6.706			•			•	•	•			•	•			
31	7.830	7.413	6.935			•			•	•	•			•	•			
32	8.070	7.652	7.183			•			•	•	•			•	•			
33	8.300	7.890	7.412			•			•	•	•			•	•			
34	8.540	8.129	7.660			•			•	•	•			•	•			
35	8.780	8.367	7.889			•			•	•	•			•	•			
36	9.020	8.606	8.137			•			•	•	•			•	•	•	•	•
37	9.260	8.844	8.367			•			•	•	•			•	•	•	•	•
38	9.500	9.083	8.614			•			•	•	•			•	•	•	•	•
39	9.740	9.321	8.844			•			•	•	•			•	•	•	•	•
40	9.980	9.560	9.091			•			•	•	•			•	•	•	•	•
41	10.220	9.798	9.321			•			•	•	•			•	•	•	•	•
42	10.460	10.037	9.568			•			•	•	•			•	•	•	•	•
43	10.700	10.275	9.799			•			•	•	•			•	•	•	•	•
44	10.940	10.514	10.045			•			•	•	•			•	•	•	•	•
45	11.180	10.752	10.276			•			•	•	•			•	•	•	•	•
46	11.420	10.991	10.522			•			•	•	•			•	•	•	•	•
47	11.650	11.229	10.754			•			•	•	•			•	•	•	•	•
48	11.890	11.468	10.999			•			•	•	•			•	•	•	•	•
49	12.130	11.706	11.231			•			•	•	•			•	•	•	•	•
50	12.370	11.945	11.476			•			•	•	•			•	•	•	•	•
51	12.610	12.183	11.708			•			•	•	•			•	•	•	•	•
52	12.850	12.422	11.953			•			•	•	•			•	•	•	•	•
53	13.090	12.660	12.186			•			•	•	•			•	•	•	•	•
54	13.330	12.889	12.430			•			•	•	•			•	•	•	•	•
55	13.570	13.137	12.663			•			•	•	•			•	•	•	•	•
56	13.810	13.376	12.907			•			•	•	•			•	•	•	•	•
57	14.040	13.615	13.140			•			•	•	•			•	•	•	•	•
58	14.280	13.853	13.384			•			•	•	•			•	•	•	•	•
59	14.520	14.092	13.618			•			•	•	•			•	•	•	•	•
60	14.760	14.330	13.861			•			•	•	•			•	•	•	•	•
70	17.150	16.717	16.248			•			•	•	•			•	•	•	•	•
72	17.630	17.195	16.726			•			•	•	•			•	•	•	•	•
80	19.540	19.103	18.634			•			•	•	•			•	•	•	•	•
84	20.490	20.058	19.589			•			•	•	•			•	•	•	•	•
96	23.360	22.922	22.453			•			•	•	•			•	•	•	•	•
112	27.180	26.741	26.272			•			•	•	•			•	•	•	•	•

• Denotes stocking item

■ Indicates ser screw at 90 degrees and 180 degrees from keyway

# HOW TO ORDER

TSUBAKI STOCK SPROCKETS



No.  
**60**

**3/4" Pitch:  
STAINLESS STEEL PLAIN BORE**

Chain Data	
Size	60SS
Pitch	3/4"
Inside Width	1/2"
Roller Diameter	0.469"
Nominal Tooth Width:	0.459"

How to Order Code: Example Model # for 60 Pitch Plain Bore Stainless Steel Sprockets

<b>A</b>	<b>60</b>	<b>B</b>	<b>25</b>					<b>SS</b>
Altered <sup>¶</sup>	Chain Pitch in Inches	Hub Type:	Number of Teeth					Material
A: Alteration Required	60: 3/4" Pitch	B: Hub Extension One Side	12	17	21	25	35	SS: 304 Stainless Steel Construction
			13	18	22	26	40	
			14	19	23	28	45	
			15	20	24	30	60	
			16					

<sup>¶</sup> Alteration field only to be denoted if a deviation from standard is required. Please reference Alterations in engineering section, page 182.

# No. 60

## STAINLESS STEEL SPROCKET DIMENSIONS

Tsubaki Stock Sprockets

All dimensions in inches unless noted.

No. 60 Stainless Steel Sprocket Diameters				Type "B" Plain Bore					
No. Teeth	Outside Diameter	Pitch Diameter	Caliper Diameter	Plain Bore	MAX Bore*	Hub Dia.	LTB	Hub Style	Wt. Lbs.
12	3.250	2.898	2.429	0.750	1.375	2.375 "	1.250	S	1.50
13	3.490	3.134	2.642	0.750	1.500	2.344	1.250	S	1.80
14	3.740	3.371	2.902	0.750	1.750	2.563	1.250	S	2.00
15	3.980	3.608	3.119	0.750	1.875	2.875	1.250	S	2.40
16	4.220	3.845	3.375	0.750	2.000	3.063	1.250	S	2.80
17	4.460	4.082	3.595	0.750	2.250	3.250	1.250	E	3.30
18	4.700	4.319	3.850	0.750	2.375	3.500	1.250	E	3.80
19	4.950	4.557	4.072	0.750	2.375	3.500	1.250	E	4.00
20	5.190	4.794	4.325	0.750	2.625	3.875	1.250	E	4.60
21	5.430	5.033	4.549	0.750	2.750	4.000	1.250	E	5.00
22	5.670	5.270	4.801	0.750	2.750	4.000	1.250	E	5.30
23	5.910	5.508	5.026	0.750	2.750	4.000	1.250	E	5.70
24	6.150	5.746	5.277	0.750	2.750	4.000	1.250	E	5.90
25	6.390	5.984	5.503	0.750	2.750	4.000	1.250	E	6.10
26	6.630	6.222	5.753	0.750	2.750	4.000	1.250	E	6.30
28	7.110	6.698	6.229	0.750	2.750	4.000	1.250	E	6.70
30	7.590	7.175	6.706	0.750	2.750	4.000	1.250	E	7.00
35	8.780	8.367	7.889	1.000	2.750	4.000	1.250	E	9.00
40	9.980	9.560	9.091	1.000	2.750	4.250	1.250	E	11.70
45	11.180	10.752	10.276	1.000	2.750	4.250	1.250	E	14.50
60	14.760	14.330	13.861	1.250	2.750	4.250	1.750	E	25.00

\* Dimensions shown allow for standard keyway with set screw at 90 degrees

\*\* Has recessed groove in hub for chain clearance

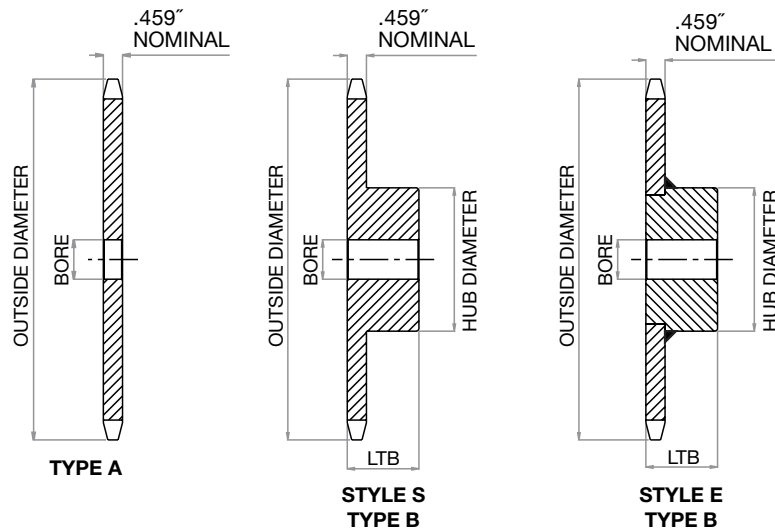

# HOW TO ORDER

TSUBAKI STOCK SPROCKETS



## No. 60 3/4" Pitch: MULTI-STRAND

Chain Data	
Size	60-2, 60-3
Pitch	3/4"
Inside Width	1/2"
Roller Diameter	0.469"
Nominal Tooth Width:	0.444"

How to Order Code: Example Model # for 60 Pitch Multi-Strand Carbon Steel Sprockets

<b>A</b>	<b>D</b>	<b>60</b>	<b>B</b>	<b>18</b>
----------	----------	-----------	----------	-----------

Altered <sup>1</sup>	Multi	Chain Pitch in Inches	Hub Type	Number of Teeth				
A: Alteration Required	D: Double Strand	60: 3/4" Pitch	B: Hub Extension One Side	Double Strand				
				11	16	21	26	40
				12	17	22	30	45
				13	18	23	32	48
				14	19	24	35	60
	15			20	25	36		
	Triple Strand							
	11			15	19	23	30	
	12			16	20	24	35	
	13			17	21	25	36	
14	18	22	26					

<sup>1</sup> Alteration field only to be denoted if a deviation from standard is required. Please reference Alterations in engineering section, page 182.

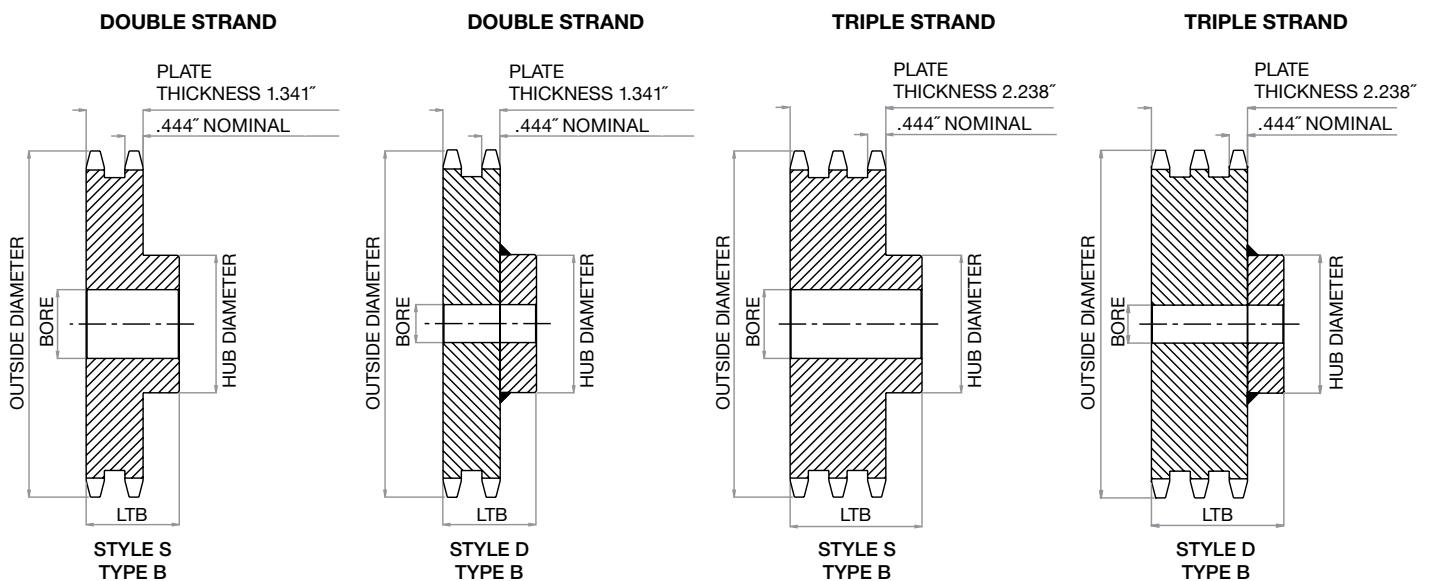

# No. 60

## MULTI-STRAND SPROCKET DIMENSIONS

Tsubaki Stock Sprockets

All dimensions in inches unless noted.

No. 60 Multi-Strand Sprocket Diameters			Dimensional Data: Double Strand Sprockets					
No. Teeth	Outside Diameter	Plain Bore	Hub Diameter	LTB	MAX Bore *	Hub Type	Hub Style	Weight Lbs.
11	3.000	1.000	1.813	2.125	1.250	B	S	1.62
12	3.250	1.000	2.125	2.125	1.438	B	S	2.20
13	3.490	1.000	2.250	2.125	1.500	B	S	2.60
14	3.740	1.000	2.500	2.125	1.750	B	S	3.24
15	3.980	1.000	2.813	2.125	1.875	B	S	3.96
16	4.220	1.000	3.000	2.125	2.000	B	S	4.62
17	4.460	1.000	3.250	2.125	2.250	B	S	5.40
18	4.700	1.000	3.500	2.125	2.375	B	S	6.24
19	4.950	1.000	3.688	2.125	2.500	B	S	7.00
20	5.190	1.000	3.750	2.125	2.500	B	S	7.72
21	5.430	1.000	4.125	2.125	2.750	B	S	8.82
22	5.670	1.000	4.250	2.125	2.750	B	S	9.68
23	5.910	1.000	4.250	2.125	2.750	B	S	10.30
24	6.150	1.000	4.250	2.125	2.750	B	S	11.14
25	6.390	1.000	4.250	2.125	2.750	B	S	11.96
26	6.630	1.000	4.250	2.125	2.750	B	S	12.70
30	7.590	1.000	4.250	2.125	2.750	B	S	16.36
32	8.070	1.250	4.500	2.375	3.000	B	S	19.52
35	8.780	1.250	4.500	2.375	3.000	B	S	22.80
36	9.020	1.250	4.500	2.375	3.000	B	S	23.82
40	9.980	1.250	4.750	2.750	3.250	B	S	30.84
45	11.180	1.250	4.750	2.750	3.250	B	S	37.08
48	11.890	1.250	4.750	2.750	3.250	B	D	44.90
60	14.760	1.250	4.750	2.750	3.250	B	D	63.10

\* Dimensions shown allow for standard keyway with set screw at 90 degrees

All dimensions in inches unless noted.

No. 60 Multi-Strand Sprocket Diameters			Dimensional Data: Triple Strand Sprockets					
No. Teeth	Outside Diameter	Plain Bore	Hub Diameter	LTB	MAX Bore *	Hub Type	Hub Style	Weight Lbs.
11	3.000	1.000	1.813	3.000	1.250	B	S	2.50
12	3.250	1.000	2.125	3.000	1.438	B	S	3.30
13	3.490	1.000	2.250	3.000	1.500	B	S	3.90
14	3.740	1.000	2.500	3.000	1.750	B	S	4.50
15	3.980	1.000	2.688	3.000	1.875	B	S	5.40
16	4.220	1.000	3.000	3.000	2.000	B	S	6.50
17	4.460	1.000	3.250	3.000	2.250	B	S	7.70
18	4.700	1.000	3.500	3.000	2.375	B	S	8.50
19	4.950	1.000	3.688	3.000	2.500	B	S	10.00
20	5.190	1.000	3.750	3.000	2.500	B	S	11.20
21	5.430	1.000	4.125	3.000	2.750	B	S	12.50
22	5.670	1.000	4.250	3.000	2.750	B	S	13.20
23	5.910	1.000	4.250	3.000	2.750	B	S	14.60
24	6.150	1.000	4.250	3.000	2.750	B	S	15.80
25	6.390	1.000	4.250	3.000	2.750	B	S	17.00
26	6.630	1.000	4.250	3.000	2.750	B	S	18.60
30	7.590	1.000	4.250	3.000	2.750	B	S	23.20
35	8.780	1.250	4.500	3.250	3.000	B	S	34.50
36	9.020	1.250	4.500	3.250	3.000	B	S	37.00

\* Dimensions shown allow for standard keyway with set screw at 90 degrees



# HOW TO ORDER

TSUBAKI STOCK SPROCKETS



## No. 60 3/4" Pitch: DOUBLE SINGLE

Chain Data	
Size	60
Pitch	3/4"
Inside Width	1/2"
Roller Diameter	0.469"
Nominal Tooth Width:	0.459"

How to Order Code: Example Model # for 60 Pitch Double Single Carbon Steel Sprockets

<b>A</b>	<b>DS</b>	<b>60</b>	<b>A</b>	<b>19</b>																				
Altered <sup>!!</sup>	Multi	Chain Pitch in Inches	Hub Type	Number of Teeth																				
A: Alteration Required	DS: Double Single	60: 3/4" Pitch	A: No Hub Extension	<table border="1"> <tr> <td>13</td> <td>17</td> <td>21</td> <td></td> <td></td> </tr> <tr> <td>14</td> <td>18</td> <td></td> <td></td> <td></td> </tr> <tr> <td>15</td> <td>19</td> <td></td> <td></td> <td></td> </tr> <tr> <td>16</td> <td>20</td> <td></td> <td></td> <td></td> </tr> </table>	13	17	21			14	18				15	19				16	20			
13	17	21																						
14	18																							
15	19																							
16	20																							

<sup>!!</sup>Alteration field only to be denoted if a deviation from standard is required. Please reference Alterations in engineering section, page 182.

How to Order Code: Example Model # for 60 Pitch Double Single TAPER-LOCK® Carbon Steel Sprockets

<b>A</b>	<b>DS</b>	<b>60</b>	<b>A</b>	<b>TL</b>	<b>24</b>																				
Altered <sup>!!</sup>	Multi	Chain Pitch in Inches	Hub Type	TAPER-LOCK®	Number of Teeth																				
A: Alteration Required	DS: Double Single	60: 3/4" Pitch	A: No Hub Extension	TAPER-LOCK® hub with set screws	<table border="1"> <tr> <td>17</td> <td>21</td> <td></td> <td></td> <td></td> </tr> <tr> <td>18</td> <td>23</td> <td></td> <td></td> <td></td> </tr> <tr> <td>19</td> <td>24</td> <td></td> <td></td> <td></td> </tr> <tr> <td>20</td> <td></td> <td></td> <td></td> <td></td> </tr> </table>	17	21				18	23				19	24				20				
17	21																								
18	23																								
19	24																								
20																									

<sup>!!</sup>Alteration field only to be denoted if a deviation from standard is required. Please reference Alterations in engineering section, page 182.

TAPER-LOCK® bushing is not included with the sprocket. They are to be ordered separately. Please refer to the table below for general guidelines. Specific details are found in the Bushing Section of this catalog beginning on page 164.

TAPER-LOCK® Bushings	
Bushing #	Bore Range
1615	0.500 - 1.688"
2012	0.500 - 2.125"
2517	0.500 - 2.688"

All dimensions in inches unless noted.

No. 60 Double Single Sprocket Diameters			Dimensional Data: Double Single Sprockets				
No. Teeth	Outside Dia.	Plain Bore	LTB	C	D	MAX Bore *	Weight Lbs.
13	3.490	0.750	1.938	1.484	2.344	1.500	2.60
14	3.740	0.750	1.938	1.484	2.563	1.750	3.20
15	3.980	0.750	1.938	1.484	2.875	1.875	3.80
16	4.220	0.750	1.938	1.484	3.047	2.000	4.50
17	4.460	0.750	1.938	1.484	3.250	2.250	5.30
18	4.700	0.750	1.938	1.484	3.500	2.375	6.50
19	4.950	0.750	1.938	1.484	3.703	2.500	6.80
20	5.190	0.750	1.938	1.484	3.953	2.750	7.00
21	5.430	0.750	1.938	1.484	4.188	2.875	7.50

\* Dimensions shown allow for standard keyway with set screw at 90 degrees

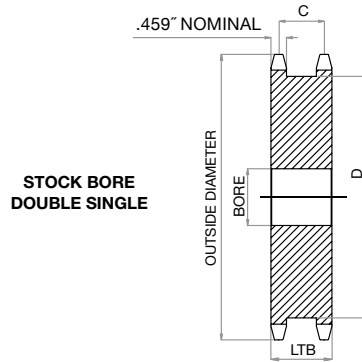

All dimensions in inches unless noted.

No. 60 Double Single TAPER-LOCK® Sprocket Diameters			Dimensional Data: Double Single TAPER-LOCK® Sprockets				
No. Teeth	Outside Dia.	Bushing #	LTB	C	D	MAX Bore *	Weight Lbs.
17	4.460	1615	1.938	1.484	3.218	1.688	4.50
18	4.700	2012	1.938	1.484	3.469	2.125	5.00
19	4.950	2012	1.938	1.484	3.703	2.125	5.80
20	5.190	2517	1.938	1.484	3.953	2.688	5.60
21	5.430	2517	1.938	1.484	4.188	2.688	6.40
23	5.910	2517	1.938	1.484	4.672	2.688	7.30
24	6.150	2517	1.938	1.484	4.906	2.688	8.20

\* Please reference TAPER-LOCK® bushing dimension table on page 165 for specific information on MAX Bore and keyway data.

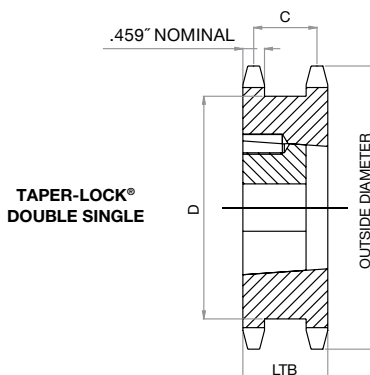

# HOW TO ORDER

TSUBAKI STOCK SPROCKETS



## No. 60 3/4" Pitch: TAPER-LOCK®

Chain Data	
Size	60
Pitch	3/4"
Inside Width	1/2"
Roller Diameter	0.469"
Nominal Tooth Width:	0.459"

How to Order Code: Example Model # for 60 Pitch TAPER-LOCK® Carbon Steel Sprockets

<b>A</b>	<b>60</b>	<b>B</b>	<b>TL</b>	<b>18</b>				
Altered <sup>†</sup>	Chain Pitch in Inches	Hub Type	TAPER-LOCK®	Number of Teeth				
A: Alteration Required	60: 3/4" Pitch	B: Hub Extension One Side	TAPER-LOCK® hub with set screws	11	18	25	40	72
				12	19	26	42	80
				13	20	28	45	
				14	21	30	48	
				15	22	32	54	
				16	23	35	60	
				17	24	36	70	

<sup>†</sup> Alteration field only to be denoted if a deviation from standard is required. Please reference Alterations in engineering section, page 182.

TAPER-LOCK® bushing is not included with the sprocket. They are to be ordered separately. Please refer to the table below for general guidelines. Specific details are found in the Bushing Section of this catalog beginning on page 164.

TAPER-LOCK® Bushings	
Bushing #	Bore Range
1008	0.500 - 1.000"
1210	0.500 - 1.250"
1610	0.500 - 1.688"
2012	0.500 - 2.125"
2517	0.500 - 2.688"

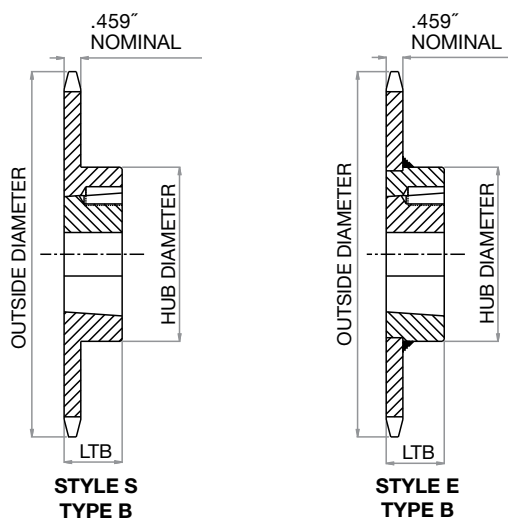

All dimensions in inches unless noted.

No. 60 TAPER-LOCK® Sprockets			Dimensional Data TAPER-LOCK® Sprockets					
No. Teeth	Outside Diameter	Bushing #	MAX Bore *	LTB	Hub Diameter	Hub Type	Hub Style	Weight Lbs.
11	3.000	1008	1.000	0.875	1.813 <sup>ˆˆ</sup>	B	S	0.60
12	3.250	1008	1.000	0.875	1.938	B	S	0.80
13	3.490	1210	1.250	1.000	2.469 <sup>ˆˆ</sup>	B	S	0.80
14	3.740	1210	1.250	1.000	2.469	B	S	1.00
15	3.980	1610	1.688	1.000	2.781	B	S	1.00
16	4.220	1610	1.688	1.000	3.000	B	S	1.40
17	4.460	1610	1.688	1.000	3.250	B	S	1.80
18	4.700	1610	1.688	1.000	3.500	B	S	1.90
19	4.950	1610	1.688	1.000	3.500	B	S	2.20
20	5.190	2012	2.125	1.250	3.938	B	S	2.20
21	5.430	2012	2.125	1.250	4.000	B	S	2.50
22	5.670	2012	2.125	1.250	4.000	B	E	2.80
23	5.910	2012	2.125	1.250	4.000	B	E	3.10
24	6.150	2012	2.125	1.250	3.563	B	E	3.40
25	6.390	2012	2.125	1.250	3.563	B	E	3.70
26	6.630	2012	2.125	1.250	3.563	B	E	4.00
28	7.110	2012	2.125	1.250	3.563	B	E	4.60
30	7.590	2012	2.125	1.250	3.563	B	E	5.20
32	8.070	2012	2.125	1.250	3.563	B	E	5.60
35	8.780	2012	2.125	1.250	3.563	B	E	6.40
36	9.020	2012	2.125	1.250	3.563	B	E	6.60
40	9.980	2012	2.125	1.250	3.563	B	E	8.30
42	10.460	2012	2.125	1.250	3.563	B	E	10.00
45	11.180	2012	2.125	1.250	3.563	B	E	11.50
48	11.890	2012	2.125	1.250	3.563	B	E	13.20
54	13.330	2517	2.688	1.750	4.250	B	E	17.10
60	14.760	2517	2.688	1.750	4.250	B	E	21.00
70	17.150	2517	2.688	1.750	4.250	B	E	27.60
72	17.630	2517	2.688	1.750	4.250	B	E	30.00
80	19.540	2517	2.688	1.750	4.250	B	E	36.30

\* Please reference TAPER-LOCK® bushing dimension table on page 165 for specific information on MAX Bore and keyway data.

<sup>ˆˆ</sup> Has recessed groove in hub for chain clearance

# HOW TO ORDER

TSUBAKI STOCK SPROCKETS



No.  
**60**

**3/4" Pitch:  
MULTI-STRAND TAPER-LOCK®**

Chain Data	
Size	60-2
Pitch	3/4"
Inside Width	1/2"
Roller Diameter	0.469"
Nominal Tooth Width:	0.444"

How to Order Code: Example Model # for 60 Pitch Multi-Strand TAPER-LOCK® Carbon Steel Sprockets

<b>A</b>	<b>D</b>	<b>60</b>	<b>C</b>	<b>TL</b>	<b>36</b>
----------	----------	-----------	----------	-----------	-----------

Altered <sup>†</sup>	Multi-Strand	Chain Pitch in Inches	Hub Type	TAPER-LOCK®	Number of Teeth				
A: Alteration Required	D: Double Strand	60: 3/4" Pitch	A: No Hub Extension	TAPER-LOCK® hub with set screws	A Style				
					18				
					19				
			B Style						
			13		15	17	21	30	
			14		16	20	25		
			C Style						
			36		45	60			
			42		52				
							C: Hub Extension Both Sides		

<sup>†</sup>Alteration field only to be denoted if a deviation from standard is required. Please reference Alterations in engineering section, page 182.

TAPER-LOCK® bushing is not included with the sprocket. They are to be ordered separately. Please refer to the table below for general guidelines. Specific details are found in the Bushing Section of this catalog beginning on page 164.

TAPER-LOCK® Bushings	
Bushing #	Bore Range
1215	0.500 - 1.250"
1615	0.500 - 1.688"
2012	0.500 - 2.125"
2517	0.500 - 2.688"

# No. 60

## MULTI-STRAND TAPER-LOCK® SPROCKET DIMENSIONS

Tsubaki Stock Sprockets

All dimensions in inches unless noted.

Double Strand No. 60 TAPER-LOCK® Sprockets			Dimensional Data Multi-Strand TAPER-LOCK® Sprockets					
No. Teeth	Outside Diameter	Bushing #	MAX Bore *	LTB	Hub Diameter	Hub Type	Hub Style	Weight Lbs.
13	3.490	1215	1.250	1.500	2.250	B	S	1.20
14	3.740	1215	1.250	1.500	2.500	B	S	1.60
15	3.980	1615	1.688	1.500	2.813	B	S	1.30
16	4.220	1615	1.688	1.500	3.000	B	S	2.20
17	4.460	1615	1.688	1.500	3.250	B	S	2.50
18	4.700	2012	2.125	1.250	-	A	S	3.00
19	4.950	2012	2.125	1.250	-	A	S	3.50
20	5.190	2517	2.688	1.750	3.688	B	S	4.00
21	5.430	2517	2.688	1.750	4.188	B	S	5.00
25	6.390	2517	2.688	1.750	5.156	B	S	7.50
30	7.590	2517	2.688	1.750	6.344	B	S	13.50
36	9.020	2517	2.688	1.750	4.250	C	S	17.50
42	10.460	2517	2.688	1.750	4.250	C	S	25.50
45	11.180	2517	2.688	1.750	4.250	C	S	29.50
52	12.850	2517	2.688	1.750	4.250	C	S	41.00
60	14.760	2517	2.688	1.750	4.250	C	S	55.30

\* Please reference TAPER-LOCK® bushing dimension table on page 165 for specific information on MAX Bore and keyway data.

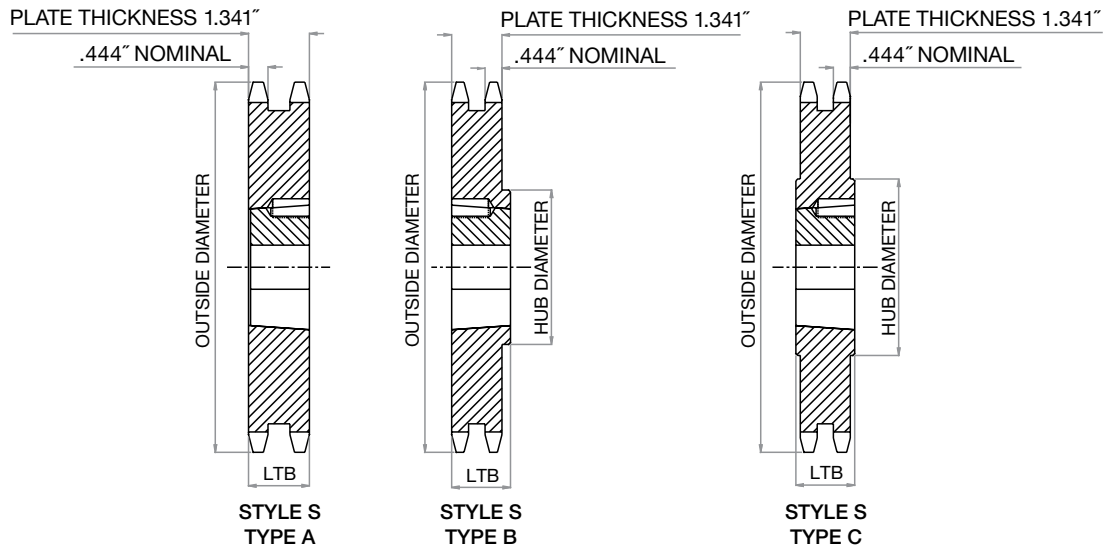

# HOW TO ORDER

TSUBAKI STOCK SPROCKETS



No.  
**60** 3/4" Pitch: QD®

Chain Data	
Size	60
Pitch	3/4"
Inside Width	1/2"
Roller Diameter	0.469"
Nominal Tooth Width:	0.459"

How to Order Code: Example Model # for 60 Pitch QD® Carbon Steel Sprockets

<b>A</b>	<b>60</b>	<b>SDS</b>	<b>19</b>
----------	-----------	------------	-----------

Altered <sup>!!</sup>	Chain Pitch in Inches	QD® Hub Type	Number of Teeth				
A: Alteration Required	60: 3/4" Pitch	JA: QD® Hub 11 - 13 tooth sprocket	11				
			12				
			13				
		SH: QD® Hub 14 - 16 tooth sprocket	14				
			15				
			16				
		SDS: QD® Hub 17 - 25 tooth sprocket	17	20	23		
			18	21	24		
			19	22	25		
		SK: QD® Hub 26 - 40 tooth sprocket	26	30	36		
			27	32	40		
			28	35			
		SF: QD® Hub 42 - 96 tooth sprocket	42	54	72	96	
			45	60	80		
			48	70	84		

<sup>!!</sup>Alteration field only to be denoted if a deviation from standard is required. Please reference Alterations in engineering section, page 182.

QD® bushing is not included with the sprocket. They are to be ordered separately. Please refer to the table below for general guidelines. Specific details are found in the Bushing Section of this catalog beginning on page 170.

QD® Bushings	
Bushing #	Bore Range
JA	0.500 - 1.250"
SH	0.500 - 1.688"
SDS	0.500 - 2.000"
SK	0.500 - 2.625"
SF	0.500 - 2.938"

# No. 60

## QD® SPROCKET DIMENSIONS

Tsubaki Stock Sprockets

All dimensions in inches unless noted.

No. 60 QD® Sprockets			Dimensional Data QD® Sprockets									
No. Teeth	Outside Dia.	QD® Bushing #	MAX Bore *	Hub Dia.	LTB	X	Y	L	F	Hub Type	Hub Style	Weight Lbs.
11	3.000	JA	1.250	2.063	0.625	1.125	1.125	0.547	2.063	B	S	0.46
12	3.250	JA	1.250	2.063	0.625	1.125	1.125	0.547	2.063	B	S	0.60
13	3.490	JA	1.250	2.250	0.625	1.125	1.125	0.547	2.063	B	S	0.75
14	3.740	SH	1.688	2.688	0.813	1.437	1.437	0.797	2.688	B	S	0.88
15	3.980	SH	1.688	2.750	0.813	1.437	1.437	0.797	2.688	B	S	1.08
16	4.220	SH	1.688	3.000	0.813	1.437	1.437	0.797	2.688	B	S	1.25
17	4.460	SDS	2.000	3.250	0.750	1.500	1.500	0.859	3.188	B	S	1.38
18	4.700	SDS	2.000	3.500	0.750	1.500	1.500	0.859	3.188	B	S	1.56
19	4.950	SDS	2.000	3.500	0.750	1.500	1.500	0.859	3.188	B	S	1.76
20	5.190	SDS	2.000	3.500	0.750	1.500	1.500	0.859	3.188	B	S	2.00
21	5.430	SDS	2.000	3.500	0.750	1.500	1.500	0.859	3.188	B	S	2.20
22	5.670	SDS	2.000	3.500	0.750	1.500	1.500	0.859	3.188	B	S	2.44
23	5.910	SDS	2.000	3.500	0.750	1.500	1.500	0.859	3.188	B	E	2.70
24	6.150	SDS	2.000	3.500	0.750	1.500	1.500	0.859	3.188	B	E	2.94
25	6.390	SDS	2.000	3.500	0.750	1.500	1.500	0.859	3.188	B	E	3.24
26	6.630	SK	2.625	4.250	1.250	2.125	2.125	1.422	3.875	B	E	4.18
27	6.870	SK	2.625	4.250	1.250	2.125	2.125	1.422	3.875	B	E	4.52
28	7.110	SK	2.625	4.250	1.250	2.125	2.125	1.422	3.875	B	E	4.72
30	7.590	SK	2.625	4.250	1.250	2.125	2.125	1.422	3.875	B	E	5.34
32	8.070	SK	2.625	4.250	1.250	2.125	2.125	1.422	3.875	B	E	6.10
35	8.780	SK	2.625	4.250	1.250	2.125	2.125	1.422	3.875	B	E	7.42
36	9.020	SK	2.625	4.250	1.250	2.125	2.125	1.422	3.875	B	E	7.70
40	9.980	SK	2.625	4.250	1.250	2.125	2.125	1.422	3.875	B	E	9.56
42	10.460	SF	2.938	5.000	1.250	2.250	2.250	1.547	4.625	B	E	10.78
45	11.180	SF	2.938	5.000	1.250	2.250	2.250	1.547	4.625	B	E	12.40
48	11.890	SF	2.938	5.000	1.250	2.250	2.250	1.547	4.625	B	E	14.25
54	13.330	SF	2.938	5.000	1.250	2.250	2.250	1.547	4.625	B	E	17.02
60	14.760	SF	2.938	5.000	1.250	2.250	2.250	1.547	4.625	B	E	20.76
70	17.150	SF	2.938	5.000	1.250	2.250	2.250	1.547	4.625	B	E	28.60
72	17.630	SF	2.938	5.000	1.250	2.250	2.250	1.547	4.625	B	E	29.58
80	19.540	SF	2.938	5.000	1.250	2.250	2.250	1.547	4.625	B	E	38.24
84	20.490	SF	2.938	5.000	1.250	2.250	2.250	1.547	4.625	B	E	40.94
96	23.360	SF	2.938	5.000	1.250	2.250	2.250	1.547	4.625	B	E	52.40

\* Please reference QD® bushing dimension table on page 171 for specific information on MAX Bore and keyway data.

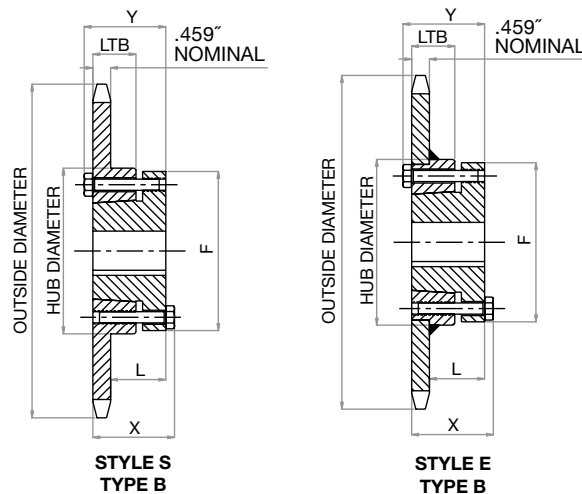



# HOW TO ORDER

TSUBAKI STOCK SPROCKETS



No. **80** 1" Pitch:  
PLAIN BORE

Chain Data	
Size	80
Pitch	1"
Inside Width	5/8"
Roller Diameter	0.625"
Nominal Tooth Width:	0.575"

How to Order Code: Example Model # for 80 Pitch Plain Bore Carbon Steel Sprockets

<b>A</b>	<b>80</b>	<b>A</b>	<b>37</b>
----------	-----------	----------	-----------

Altered <sup>11</sup>	Chain Pitch in Inches	Hub Type	Number of Teeth				
			9	22	35	48	70
A: Alteration Required	80: 1" Pitch	A: No Hub Extension	10	23	36	49	72
			11	24	37	50	76
			12	25	38	51	80
			13	26	39	52	84
			14	27	40	53	90
			15	28	41	54	96
			16	29	42	55	112
			17	30	43	56	
			18	31	44	57	
			19	32	45	59	
			20	33	46	60	
			21	34	47	65	
		B: Hub Extension One Side	8	19	30	41	52
			9	20	31	42	53
			10	21	32	43	54
			11	22	33	44	55
			12	23	34	45	56
			13	24	35	46	57
		C: Hub Extension Both Sides	70	76	84	96	
			72	80	90	112	

<sup>11</sup> Alteration field only to be denoted if a deviation from standard is required. Please reference Alterations in engineering section, page 182.

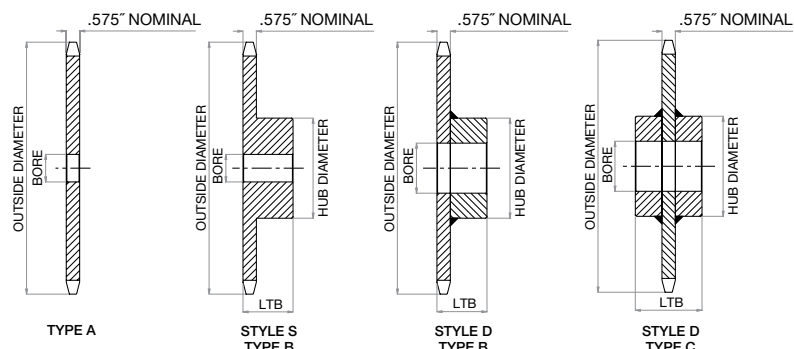

# No. 80

## PLAIN BORE SPROCKET DIMENSIONS

Tsubaki Stock Sprockets

All dimensions in inches unless noted.

No. 80 Plain Bore Sprocket Dia.				Type "A" Plain Bore		Type "B" & "C" Plain Bore						
No. Teeth	Outside Dia.	Pitch Dia.	Caliper Dia.	Plain Bore	Wt. Lbs.	Plain Bore	MAX Bore *	Hub Dia.	LTB	Hub Type	Hub Style	Wt. Lbs.
8	3.010	2.613	1.988	N/A	N/A	1.000	1.000	1.938 <sup>™</sup>	1.625	B	S	1.40
9	3.350	2.924	2.254	0.938	0.80	1.000	1.313	2.250 <sup>™</sup>	1.625	B	S	1.60
10	3.680	3.236	2.611	0.938	1.00	1.000	1.500	2.563 <sup>™</sup>	1.625	B	S	2.20
11	4.010	3.549	2.888	0.938	1.30	1.000	1.625	2.813 <sup>™</sup>	1.625	B	S	3.20
12	4.330	3.864	3.239	0.938	1.50	1.000	1.875	3.125 <sup>™</sup>	1.625	B	S	3.40
13	4.660	4.179	3.523	0.938	1.80	1.000	2.000	3.000	1.500	B	S	3.50
14	4.980	4.494	3.869	0.938	2.20	1.000	2.250	3.250	1.500	B	S	4.10
15	5.300	4.810	4.158	0.938	2.50	1.000	2.500	3.813	1.500	B	S	5.30
16	5.630	5.126	4.501	0.938	2.90	1.000	2.750	4.000	1.500	B	S	5.90
17	5.950	5.442	4.794	0.938	3.30	1.000	2.750	4.000	1.500	B	S	6.60
18	6.270	5.759	5.134	0.938	3.70	1.000	2.750	4.250	1.500	B	S	7.30
19	6.590	6.076	5.430	0.938	4.10	1.000	2.750	4.250	1.500	B	S	7.80
20	6.910	6.392	5.767	0.938	4.70	1.000	2.750	4.250	1.500	B	S	8.40
21	7.240	6.710	6.066	0.938	4.900	1.000	2.750	4.250	1.750	B	S	9.40
22	7.560	7.027	6.402	0.938	5.500	1.000	2.750	4.250	1.750	B	S	10.00
23	7.880	7.344	6.702	0.938	6.300	1.000	2.750	4.250	1.750	B	S	10.70
24	8.200	7.661	7.036	0.938	6.700	1.000	2.750	4.250	1.750	B	S	11.30
25	8.520	7.979	7.338	0.938	7.200	1.000	2.750	4.250	1.750	B	S	11.90
26	8.840	8.296	7.671	1.188	7.800	1.250	3.250	4.750	2.000	B	D	14.30
27	9.160	8.614	7.974	1.188	8.600	1.250	3.250	4.750	2.000	B	D	15.40
28	9.480	8.931	8.306	1.188	9.300	1.250	3.250	4.750	2.000	B	D	16.00
29	9.800	9.249	8.611	1.188	9.800	1.188	3.250	4.750	2.000	B	D	17.10
30	10.110	9.567	8.942	1.188	10.70	1.188	3.250	4.750	2.000	B	D	17.40
31	10.430	9.884	9.247	1.188	11.30	1.188	3.250	4.750	2.000	B	D	18.70
32	10.750	10.202	9.577	1.188	12.10	1.188	3.250	4.750	2.000	B	D	19.50
33	11.070	10.520	9.883	1.188	13.60	1.188	3.250	4.750	2.000	B	D	19.60
34	11.390	10.838	10.213	1.188	14.30	1.188	3.250	4.750	2.000	B	D	21.30
35	11.710	11.156	10.520	1.188	14.80	1.188	3.250	4.750	2.000	B	D	22.10
36	12.030	11.474	10.849	1.188	16.10	1.188	3.250	4.750	2.000	B	D	23.10
37	12.350	11.792	11.156	1.188	16.80	1.188	3.250	4.750	2.000	B	D	23.80
38	12.670	12.110	11.485	1.188	17.20	1.188	3.250	4.750	2.000	B	D	24.70
39	12.990	12.428	11.792	1.188	17.90	1.188	3.250	4.750	2.000	B	D	25.60
40	13.310	12.746	12.121	1.188	18.90	1.188	3.250	4.750	2.000	B	D	26.70
41	13.630	13.064	12.429	1.250	21.00	1.250	3.250	4.750	2.000	B	D	27.80
42	13.940	13.382	12.757	1.250	21.80	1.250	3.250	4.750	2.000	B	D	28.70
43	14.260	13.700	13.065	1.250	23.60	1.250	3.250	4.750	2.000	B	D	29.40
44	14.580	14.018	13.393	1.250	24.30	1.250	3.250	4.750	2.000	B	D	29.90
45	14.900	14.336	13.702	1.250	25.20	1.250	3.250	4.750	2.000	B	D	31.40
46	15.220	14.654	14.029	1.250	26.60	1.250	3.250	4.750	2.000	B	D	33.10
47	15.540	14.972	14.338	1.250	26.40	1.250	3.250	4.750	2.000	B	D	34.00
48	15.860	15.290	14.665	1.250	27.80	1.250	3.250	4.750	2.000	B	D	35.50
49	16.180	15.608	14.975	1.250	28.90	1.250	3.250	4.750	2.000	B	D	35.80
50	16.500	15.926	15.301	1.250	30.90	1.250	3.250	4.750	2.000	B	D	37.30
51	16.810	16.244	15.611	1.250	32.20	1.250	3.250	4.750	2.000	B	D	38.50
52	17.130	16.562	15.937	1.250	33.00	1.250	3.250	4.750	2.000	B	D	39.40
53	17.450	16.880	16.248	1.250	34.90	1.250	3.250	4.750	2.000	B	D	41.30
54	17.770	17.198	16.573	1.250	36.60	1.250	3.500	5.250	2.000	B	D	44.70
55	18.090	17.516	16.884	1.250	37.50	1.250	3.500	5.250	2.000	B	D	45.60
56	18.410	17.835	17.210	1.250	39.40	1.250	3.500	5.250	2.000	B	D	47.50
57	18.730	18.153	17.521	1.250	40.40	1.250	3.500	5.250	2.000	B	D	48.50
58	19.040	18.471	17.846	1.250	41.30	1.250	3.500	5.250	2.000	B	D	50.50
59	19.360	18.789	18.157	1.250	42.90	1.250	3.500	5.250	2.000	B	D	52.10
60	19.680	19.107	18.482	1.250	45.30	1.250	3.500	5.250	2.000	B	D	54.50
65	21.270	20.698	20.067	1.250	52.20	1.250	3.500	5.250	2.000	B	D	61.80
70	22.870	22.289	21.644	1.500	59.80	1.500	4.250	6.250	3.500	C	D	75.70
72	23.500	22.926	22.301	1.500	65.70	1.500	4.250	6.250	3.500	C	D	81.40
80	26.050	25.471	24.846	1.500	79.60	1.500	4.250	6.250	3.500	C	D	89.90
84	27.330	26.744	26.119	1.500	86.10	1.500	4.250	6.250	3.500	C	D	99.20
96	31.150	30.563	29.938	1.500	120.00	1.500	4.250	6.250	3.500	C	D	117.00
112	36.240	35.655	35.030	1.500	166.00	1.500	4.250	6.250	3.500	C	D	154.00

\* Dimensions shown allow for standard keyway with set screw at 90 degrees

™ Has recessed groove in hub for chain clearance

# HOW TO ORDER

TSUBAKI STOCK SPROCKETS



## No. 80 1" Pitch: FINISHED BORE

Chain Data	
Size	80
Pitch	1"
Inside Width	5/8"
Roller Diameter	0.625"
Nominal Tooth Width:	0.575"

How to Order Code: Example Model # for 80 Pitch Finished Bore Carbon Steel Sprockets

<b>80</b>	<b>B</b>	<b>60</b>	<b>F -</b>	<b>2R</b>
-----------	----------	-----------	------------	-----------

Chain Pitch in Inches	Hub Type	Number of Teeth				Finished Bore	Hub Bore**		
		9	24	39	54				
80: 1" Pitch	B: Hub Extension One Side					F: Hub Extension Machined with keyway and two set screws	1	1"	(1.000")
							1B	1-1/8"	(1.125")
							1C	1-3/16"	(1.188")
							1D	1-1/4"	(1.250")
							1F	1-3/8"	(1.375")
							1G:	1-7/16"	(1.438")
							1H:	1-1/2"	(1.500")
							1J	1-5/8"	(1.625")
							1L	1-3/4"	(1.750")
							1P	1-7/8"	(1.875")
							1R	1-15/16"	(1.938")
							2	2"	(2.000")
							2C	2-3/16"	(2.188")
							2G	2-7/16"	(2.438")
				2R	2-15/16"	(2.938")			

\*\*Hub bore sizes should be selected from dimensional table on the following page. Bore sizes that are not listed for a given number of sprocket teeth may be available per request as Altered.

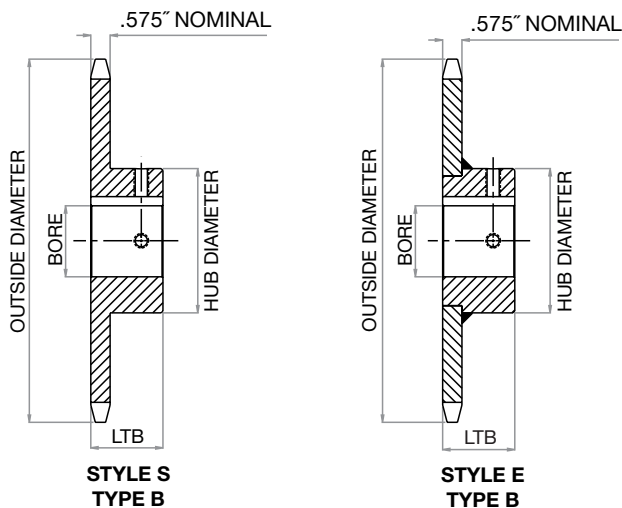

# No. 80

## FINISHED BORE SPROCKET DIMENSIONS

Tsubaki Stock Sprockets

All dimensions in inches unless noted.

No. 80 Finished Bore Sprocket Dia.				Type "F" Bored to Shaft Size (includes standard keyway and two set screws)															
No. Teeth	Outside Dia.	Pitch Dia.	Caliper Dia.	1.000"	1.125"	1.188"	1.250"	1.375"	1.438"	1.500"	1.625"	1.750"	1.875"	1.938"	2.000"	2.188"	2.438"	2.938"	
9	3.350	2.924	2.254	•	•	•	•												
10	3.680	3.236	2.611	•	•	•	•												
11	4.010	3.550	2.888	•	•	•	•	•	•	•	•								
12	4.330	3.864	3.239	•	•	•	•	•	•	•	•	•							
13	4.660	4.179	3.523	•	•	•	•	•	•	•	•	•	•	•	•	•			
14	4.980	4.494	3.869	•	•	•	•	•	•	•	•	•	•	•	•	•	•		
15	5.300	4.810	4.158	•	•	•	•	•	•	•	•	•	•	•	•	•			
16	5.630	5.126	4.501	•		•	•	•	•	•	•	•	•	•	•	•	•		
17	5.950	5.442	4.794	•		•	•	•	•	•	•	•	•	•	•	•	•	•	
18	6.270	5.759	5.134	•		•	•	•	•	•	•	•	•	•	•	•	•	•	
19	6.590	6.076	5.430	•		•	•	•	•	•	•	•	•	•	•	•	•	•	
20	6.910	6.392	5.767	•		•	•	•	•	•	•	•	•	•	•	•	•	•	
21	7.240	6.710	6.066	•		•	•	•	•	•	•	•	•	•	•	•	•	•	
22	7.560	7.027	6.402	•		•	•	•	•	•	•	•	•	•	•	•	•	•	
23	7.880	7.344	6.702	•		•	•	•	•	•	•	•	•	•	•	•	•	•	
24	8.200	7.661	7.036	•		•	•	•	•	•	•	•	•	•	•	•	•	•	
25	8.520	7.979	7.338	•		•	•	•	•	•	•	•	•	•	•	•	•	•	
26	8.840	8.296	7.671				•	•	•	•	•	•	•	•	•	•	•	•	•
27	9.160	8.614	7.974				•	•	•	•	•	•	•	•	•	•	•	•	•
28	9.480	8.931	8.306				•	•	•	•	•	•	•	•	•	•	•	•	•
29	9.800	9.249	8.611				•	•	•	•	•	•	•	•	•	•	•	•	•
30	10.110	9.567	8.942				•	•	•	•	•	•	•	•	•	•	•	•	•
31	10.430	9.884	9.247				•	•	•	•	•	•	•	•	•	•	•	•	•
32	10.750	10.202	9.577				•	•	•	•	•	•	•	•	•	•	•	•	•
33	11.070	10.520	9.883				•	•	•	•	•	•	•	•	•	•	•	•	•
34	11.390	10.838	10.213				•	•	•	•	•	•	•	•	•	•	•	•	•
35	11.710	11.156	10.520				•	•	•	•	•	•	•	•	•	•	•	•	•
36	12.030	11.474	10.849				•	•	•	•	•	•	•	•	•	•	•	•	•
37	12.350	11.792	11.156				•	•	•	•	•	•	•	•	•	•	•	•	•
38	12.670	12.110	11.485				•	•	•	•	•	•	•	•	•	•	•	•	•
39	12.990	12.428	11.792				•	•	•	•	•	•	•	•	•	•	•	•	•
40	13.310	12.746	12.121				•	•	•	•	•	•	•	•	•	•	•	•	•
41	13.630	13.064	12.429				•	•	•	•	•	•	•	•	•	•	•	•	•
42	13.940	13.382	12.757				•	•	•	•	•	•	•	•	•	•	•	•	•
43	14.260	13.700	13.065				•	•	•	•	•	•	•	•	•	•	•	•	•
44	14.580	14.018	13.393				•	•	•	•	•	•	•	•	•	•	•	•	•
45	14.900	14.336	13.702				•	•	•	•	•	•	•	•	•	•	•	•	•
46	15.220	14.654	14.029				•	•	•	•	•	•	•	•	•	•	•	•	•
47	15.540	14.972	14.338				•	•	•	•	•	•	•	•	•	•	•	•	•
48	15.860	15.290	14.665				•	•	•	•	•	•	•	•	•	•	•	•	•
49	16.180	15.608	14.975				•	•	•	•	•	•	•	•	•	•	•	•	•
50	16.500	15.926	15.301				•	•	•	•	•	•	•	•	•	•	•	•	•
51	16.810	16.244	15.611				•	•	•	•	•	•	•	•	•	•	•	•	•
52	17.130	16.562	15.937				•	•	•	•	•	•	•	•	•	•	•	•	•
53	17.450	16.880	16.248				•	•	•	•	•	•	•	•	•	•	•	•	•
54	17.770	17.198	16.573				•	•	•	•	•	•	•	•	•	•	•	•	•
55	18.090	17.516	16.884				•	•	•	•	•	•	•	•	•	•	•	•	•
56	18.410	17.835	17.210				•	•	•	•	•	•	•	•	•	•	•	•	•
57	18.730	18.153	17.521				•	•	•	•	•	•	•	•	•	•	•	•	•
58	19.040	18.471	17.846				•	•	•	•	•	•	•	•	•	•	•	•	•
59	19.360	18.789	18.157				•	•	•	•	•	•	•	•	•	•	•	•	•
60	19.680	19.107	18.482				•	•	•	•	•	•	•	•	•	•	•	•	•

- Denotes stocking item
- Indicates ser screw at 90 degrees and 180 degrees from keyway

# HOW TO ORDER

TSUBAKI STOCK SPROCKETS



## No. 80 1" Pitch: STAINLESS STEEL PLAIN BORE

Chain Data	
Size	80SS
Pitch	1"
Inside Width	5/8"
Roller Diameter	0.625"
Nominal Tooth Width:	0.575"

How to Order Code: Example Model # for 80 Pitch Plain Bore Stainless Steel Sprockets

<b>A</b>	<b>80</b>	<b>B</b>	<b>24</b>					<b>SS</b>
Altered <sup>¶</sup>	Chain Pitch in Inches	Hub Type	Number of Teeth <sup>‡</sup>					Material
A: Alteration Required	80: 1" Pitch	B: Hub Extension One Side	10	13	16	20	24	SS: 304 Stainless Steel Construction
			11	14	18	22		
			12	15	19	23		

<sup>¶</sup> Alteration field only to be denoted if a deviation from standard is required. Please reference Alterations in engineering section, page 182.

# No. 80

## STAINLESS STEEL SPROCKET DIMENSIONS

Tsubaki Stock Sprockets

All dimensions in inches unless noted.

No. 80 Stainless Steel Sprocket Diameters				Type "B" Plain Bore					
No. Teeth	Outside Diameter	Pitch Diameter	Caliper Diameter	Plain Bore	MAX Bore *	Hub Dia.	LTB	Hub Style	Wt. Lbs.
10	3.680	3.236	2.611	1.000	1.500	2.563 "	1.625	S	2.20
11	4.010	3.550	2.888	1.000	1.625	2.813 "	1.625	S	3.20
12	4.330	3.864	3.239	1.000	1.875	3.125 "	1.625	S	3.40
13	4.660	4.179	3.523	1.000	2.000	3.000	1.500	S	3.50
14	4.980	4.494	3.869	1.000	2.250	3.250	1.500	S	4.10
15	5.300	4.810	4.158	1.000	2.500	3.813	1.500	S	5.30
16	5.630	5.126	4.501	1.000	2.750	4.000	1.500	S	5.90
18	6.270	5.759	5.134	1.000	2.750	4.250	1.500	S	7.30
19	6.590	6.076	5.430	1.000	2.750	4.250	1.500	S	7.80
20	6.910	6.392	5.767	1.000	2.750	4.250	1.500	S	8.40
22	7.560	7.027	6.402	1.000	2.750	4.250	1.750	E	10.00
23	7.880	7.344	6.702	1.000	2.750	4.250	1.750	E	10.70
24	8.200	7.661	7.036	1.000	2.750	4.250	1.750	E	11.30

\* Dimensions shown allow for standard keyway with set screw at 90 degrees

" Has recessed groove in hub for chain clearance

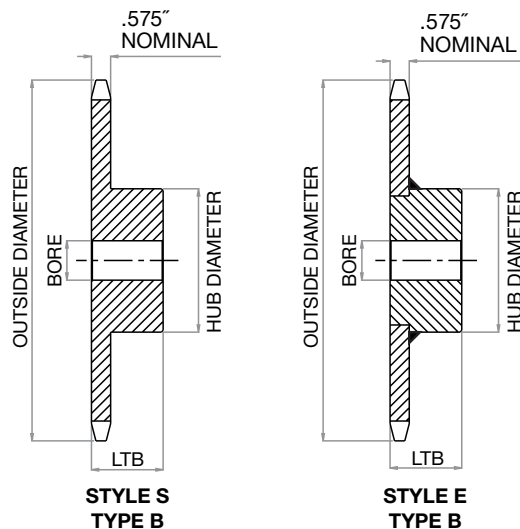

# HOW TO ORDER

TSUBAKI STOCK SPROCKETS



## No. 80 1" Pitch: MULTI-STRAND

Chain Data	
Size	80-2, 80-3
Pitch	1"
Inside Width	5/8"
Roller Diameter	0.625"
Nominal Tooth Width:	0.557"

How to Order Code: Example Model # for 80 Pitch Multi-Strand Carbon Steel Sprockets

<b>A</b>	<b>D</b>	<b>80</b>	<b>B</b>	<b>25</b>				
Altered <sup>¶</sup>	Multi	Chain Pitch in Inches	Hub Type	Number of Teeth				
A: Alteration Required	D: Double Strand	80: 1" Pitch	B: Hub Extension One Side	Double Strand				
				10	14	18	22	30
				11	15	19	23	36
				12	16	20	24	45
				13	17	21	25	
	T: Triple Strand			Triple Strand				
				11	15	19	23	36
				12	16	20	24	45
				13	17	21	25	
				14	18	22	30	

<sup>¶</sup> Alteration field only to be denoted if a deviation from standard is required. Please reference Alterations in engineering section, page 182.

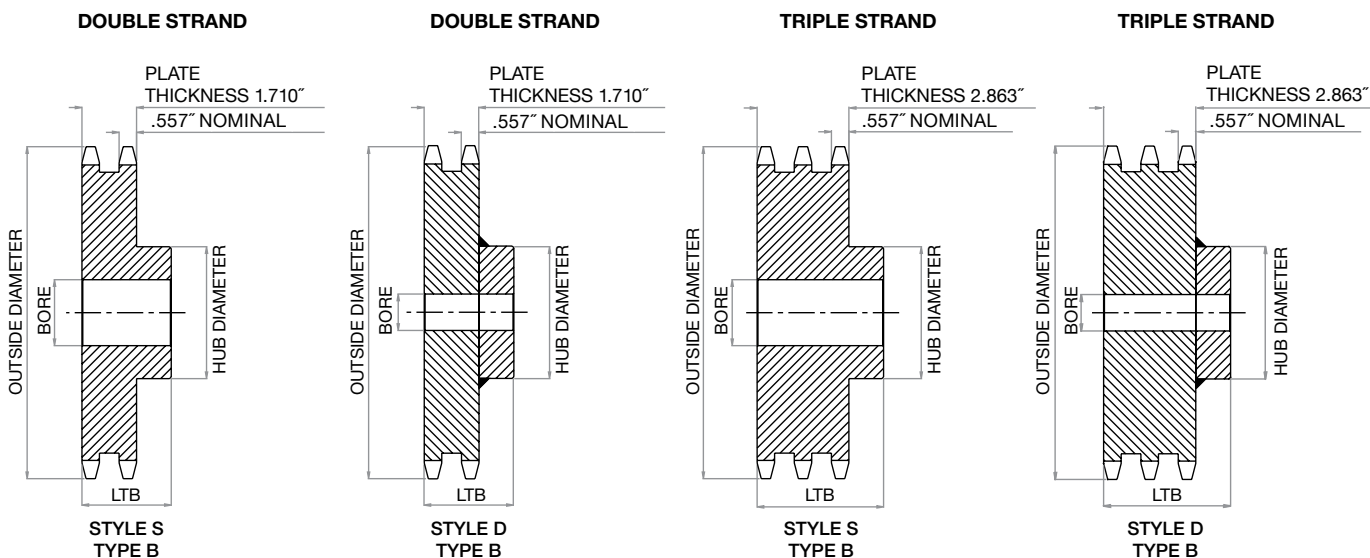

# No. 80

## MULTI-STRAND SPROCKET DIMENSIONS

Tsubaki Stock Sprockets

All dimensions in inches unless noted.

No. 80 Multi-Strand Sprocket Dia.			Dimensional Data: Double Strand Sprockets					
No. Teeth	Outside Diameter	Plain Bore	Hub Diameter	LTB	MAX Bore *	Hub Type	Hub Style	Wt. Lbs.
10	3.680	1.000	2.563 <sup>ˆˆ</sup>	2.750	1.500	B	S	3.50
11	4.010	1.000	2.500	2.500	1.750	B	S	4.00
12	4.330	1.000	2.844	2.500	1.875	B	S	5.10
13	4.660	1.000	3.156	2.500	2.250	B	S	6.30
14	4.980	1.000	3.469	2.500	2.375	B	S	7.60
15	5.300	1.000	3.797	2.500	2.500	B	S	9.00
16	5.630	1.000	4.000	2.750	2.750	B	S	11.00
17	5.950	1.000	4.422	2.750	3.000	B	S	13.20
18	6.270	1.000	4.734	2.750	3.250	B	S	15.00
19	6.590	1.000	5.000	2.750	3.313	B	S	17.00
20	6.910	1.000	5.000	2.750	3.313	B	S	18.20
21	7.240	1.000	5.000	2.750	3.313	B	S	19.50
22	7.560	1.000	5.000	2.750	3.313	B	S	21.00
23	7.880	1.000	5.000	2.750	3.313	B	S	22.80
24	8.200	1.000	5.250	2.750	3.500	B	S	25.10
25	8.520	1.000	5.250	3.000	3.500	B	S	28.30
30	10.110	1.250	5.750	3.000	3.750	B	S	39.50
36	12.030	1.250	5.750	3.125	3.750	B	D	54.20
45	14.900	1.250	5.750	3.125	3.750	B	D	73.50

\* Dimensions shown allow for standard keyway with set screw at 90 degrees

<sup>ˆˆ</sup> Has recessed groove in hub for chain clearance

All dimensions in inches unless noted.

No. 80 Multi-Strand Sprocket Dia.			Dimensional Data: Triple Strand Sprockets					
No. Teeth	Outside Diameter	Plain Bore	Hub Diameter	LTB	MAX Bore *	Hub Type	Hub Style	Wt. Lbs.
11	4.010	1.000	2.500	3.625	1.750	B	S	5.90
12	4.330	1.000	2.844	3.625	1.875	B	S	7.50
13	4.660	1.000	3.156	3.625	2.250	B	S	9.20
14	4.980	1.000	3.469	3.625	2.375	B	S	11.00
15	5.300	1.000	3.797	3.625	2.500	B	S	13.10
16	5.630	1.000	4.000	3.875	2.750	B	S	15.80
17	5.950	1.000	4.422	3.875	3.000	B	S	18.60
18	6.270	1.000	4.734	3.875	3.250	B	S	21.20
19	6.590	1.000	5.000	3.875	3.313	B	S	23.70
20	6.910	1.000	5.000	3.875	3.313	B	S	26.00
21	7.240	1.000	5.000	3.875	3.313	B	S	28.40
22	7.560	1.000	5.000	3.875	3.313	B	S	31.00
23	7.880	1.000	5.000	3.875	3.313	B	S	33.60
24	8.200	1.000	5.250	3.875	3.500	B	S	37.10
25	8.520	1.000	5.250	3.875	3.500	B	S	40.10
30	10.110	1.250	5.750	4.250	3.750	B	S	54.50
36	12.030	1.250	5.750	4.250	3.750	B	D	83.90
45	14.900	1.250	6.000	4.500	3.813	B	D	92.40

\* Dimensions shown allow for standard keyway with set screw at 90 degrees



# HOW TO ORDER

TSUBAKI STOCK SPROCKETS



## No. 80 1" Pitch: DOUBLE SINGLE

Chain Data	
Size	80
Pitch	1"
Inside Width	5/8"
Roller Diameter	0.625"
Nominal Tooth Width:	0.575"

How to Order Code: Example Model # for 80 Pitch Double Single Carbon Steel Sprockets

<b>A</b>	<b>DS</b>	<b>80</b>	<b>A</b>	<b>19</b>				
Altered <sup>!!</sup>	Multi	Chain Pitch in Inches	Hub Type	Number of Teeth				
A: Alteration Required	DS: Double Single	80: 1" Pitch	A: No Hub Extension	13	17	21		
				14	18	22		
				15	19			
				16	20			

<sup>!!</sup> Alteration field only to be denoted if a deviation from standard is required. Please reference Alterations in engineering section, page 182.

How to Order Code: Example Model # for 80 Pitch Double Single TAPER-LOCK<sup>®</sup> Carbon Steel Sprockets

<b>A</b>	<b>DS</b>	<b>80</b>	<b>A</b>	<b>TL</b>	<b>19</b>			
Altered <sup>!!</sup>	Multi	Chain Pitch in Inches	Hub Type	TAPER-LOCK <sup>®</sup>	Number of Teeth			
A: Alteration Required	DS: Double Single	80: 1" Pitch	A: No Hub Extension	TAPER-LOCK <sup>®</sup> hub with set screws	17	21		
					18	23		
					19			
					20			

<sup>!!</sup> Alteration field only to be denoted if a deviation from standard is required. Please reference Alterations in engineering section, page 182.

TAPER-LOCK<sup>®</sup> bushing is not included with the sprocket. They are to be ordered separately. Please refer to the table below for general guidelines. Specific details are found in the Bushing Section of this catalog beginning on page 164.

TAPER-LOCK <sup>®</sup> Bushings	
Bushing #	Bore Range
2517	0.500 - 2.688"
3020	0.875 - 3.250"

# No. 80

## DOUBLE SINGLE SPROCKET DIMENSIONS

Tsubaki Stock Sprockets

All dimensions in inches unless noted.

No. 80 Double Single Sprocket Diameters			Dimensional Data: Double Single Sprockets				
No. Teeth	Outside Dia.	Plain Bore	LTB	C	D	MAX Bore *	Weight Lbs.
13	4.660	1.000	2.188	1.625	3.016	2.000	6.50
14	4.980	1.000	2.188	1.625	3.344	2.250	7.70
15	5.300	1.000	2.188	1.625	3.813	2.375	9.10
16	5.630	1.000	2.188	1.625	4.000	2.688	9.50
17	5.950	1.000	2.188	1.625	4.313	2.813	10.80
18	6.270	1.000	2.188	1.625	4.641	3.125	12.10
19	6.590	1.000	2.188	1.625	4.953	3.250	12.80
20	6.910	1.000	2.188	1.625	5.281	3.500	14.00
21	7.240	1.000	2.188	1.625	5.594	3.750	16.50
22	7.560	1.000	2.188	1.625	5.922	3.750	18.40

\* Dimensions shown allow for standard keyway with set screw at 90 degrees

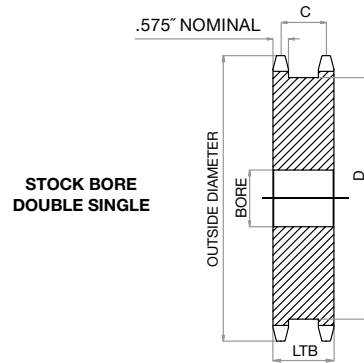

All dimensions in inches unless noted.

No. 80 Double Single TAPER-LOCK® Sprocket Diameters			Dimensional Data: Double Single TAPER-LOCK® Sprockets				
No. Teeth	Outside Dia.	Bushing #	LTB	C	D	MAX Bore *	Weight Lbs.
17	5.950	2517	2.188	1.625	4.313	2.688	7.60
18	6.270	2517	2.188	1.625	4.641	2.688	8.70
19	6.590	3020	2.188	1.625	4.953	3.250	9.70
20	6.910	3020	2.188	1.625	5.281	3.250	10.00
21	7.240	3020	2.188	1.625	5.594	3.250	12.00
23	7.880	3020	2.188	1.625	6.234	3.250	14.50

\* Please reference TAPER-LOCK® bushing dimension table on page 165 for specific information on MAX Bore and keyway data.

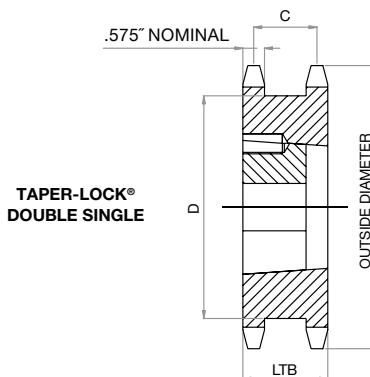

# HOW TO ORDER

TSUBAKI STOCK SPROCKETS



## No. 80 1" Pitch: TAPER-LOCK®

Chain Data	
Size	80
Pitch	1"
Inside Width	5/8"
Roller Diameter	0.625"
Nominal Tooth Width:	0.575"

How to Order Code: Example Model # for 80 Pitch TAPER-LOCK® Carbon Steel Sprockets

<b>A</b>	<b>80</b>	<b>B</b>	<b>TL</b>	<b>25</b>				
Altered <sup>‡</sup>	Chain Pitch in Inches	Hub Type	TAPER-LOCK®	Number of Teeth				
A: Alteration Required	80: 1" Pitch	B: Hub Extension One Side	TAPER-LOCK® hub with set screws	10	16	22	28	45
				11	17	23	30	48
				12	18	24	32	54
				13	19	25	35	60
				14	20	26	36	70
				15	21	27	40	80

<sup>‡</sup>Alteration field only to be denoted if a deviation from standard is required. Please reference Alterations in engineering section, page 182.

TAPER-LOCK® bushing is not included with the sprocket. They are to be ordered separately. Please refer to the table below for general guidelines. Specific details are found in the Bushing Section of this catalog beginning on page 164.

TAPER-LOCK® Bushings	
Bushing #	Bore Range
1215	0.500 - 1.250"
1615	0.500 - 1.688"
2012	0.500 - 2.125"
2517	0.500 - 2.688"
3020	0.875 - 3.250"

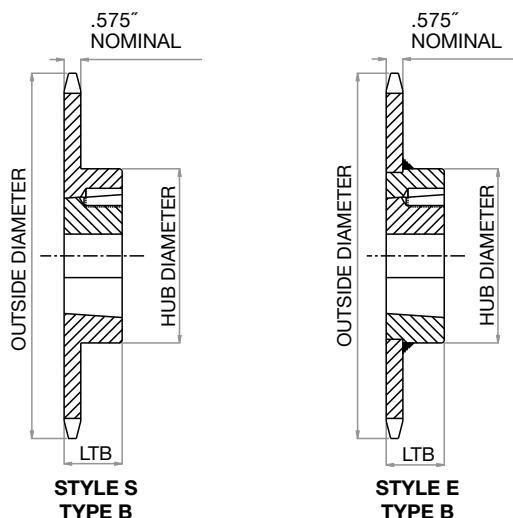

# No. 80

## TAPER-LOCK® SPROCKET DIMENSIONS

Tsubaki Stock Sprockets

All dimensions in inches unless noted.

No. 80 TAPER-LOCK® Sprockets			Dimensional Data TAPER-LOCK® Sprockets				
No. Teeth	Outside Diameter	Bushing #	Hub Diameter	LTB	MAX Bore *	Hub Style	Weight Lbs.
10	3.680	1215	2.375 "	1.500	1.250	S	1.10
11	4.010	1215	2.469 "	1.500	1.250	S	1.50
12	4.330	1615	3.000 "	1.500	1.688	S	1.80
13	4.660	1615	3.000	1.500	1.688	S	2.30
14	4.980	1615	3.343	1.500	1.688	S	2.50
15	5.300	1615	3.500	1.500	1.688	S	2.70
16	5.630	2012	4.000	1.250	2.125	S	2.80
17	5.950	2012	4.000	1.250	2.125	E	3.10
18	6.270	2012	3.563	1.250	2.125	E	3.60
19	6.590	2012	3.563	1.250	2.125	E	4.10
20	6.910	2517	4.250	1.750	2.688	E	5.50
21	7.240	2517	4.250	1.750	2.688	E	6.00
22	7.560	2517	4.250	1.750	2.688	E	6.50
23	7.880	2517	4.250	1.750	2.688	E	7.00
24	8.200	2517	4.250	1.750	2.688	E	7.50
25	8.520	2517	4.250	1.750	2.688	E	8.10
26	8.840	2517	4.250	1.750	2.688	E	8.80
27	9.160	2517	4.250	1.750	2.688	E	9.00
28	9.480	2517	4.250	1.750	2.688	E	9.50
30	10.110	2517	4.250	1.750	2.688	E	11.50
32	10.750	2517	4.250	1.750	2.688	E	12.00
35	11.710	2517	4.250	1.750	2.688	E	15.20
36	12.030	2517	4.250	1.750	2.688	E	17.00
40	13.310	2517	4.250	1.750	2.688	E	21.00
45	14.900	2517	4.250	1.750	2.688	E	26.50
48	15.860	2517	4.250	1.750	2.688	E	29.50
54	17.770	2517	4.250	1.750	2.688	E	38.50
60	19.680	2517	4.250	1.750	2.688	E	45.20
70	22.870	3020	5.250	2.000	3.250	E	52.30
80	26.050	3020	5.250	2.000	3.250	E	69.20

\* Please reference TAPER-LOCK® bushing dimension table on page 165 for specific information on MAX Bore and keyway data.

" Has recessed groove in hub for chain clearance

# HOW TO ORDER

TSUBAKI STOCK SPROCKETS



No.  
80

1" Pitch:  
MULTI-STRAND TAPER-LOCK®

Chain Data	
Size	80-2
Pitch	1"
Inside Width	5/8"
Roller Diameter	0.625"
Nominal Tooth Width:	0.557"

How to Order Code: Example Model # for 80 Pitch Multi-Strand TAPER-LOCK® Carbon Steel Sprockets

<b>A</b>	<b>D</b>	<b>80</b>	<b>B</b>	<b>TL</b>	<b>19</b>
----------	----------	-----------	----------	-----------	-----------

Altered <sup>¶</sup>	Multi-Strand	Chain Pitch in Inches	Hub Type	TAPER-LOCK®	Number of Teeth				
A: Alteration Required	D: Double Strand	80: 1" Pitch	A: No Hub Extension	TAPER-LOCK® hub with set screws	A Style				
					13	15	17		
					14	16	18		
			B Style						
			19		21				
			20		25				
			C Style						
			30		42	52			
			36		45	60			

<sup>¶</sup> Alteration field only to be denoted if a deviation from standard is required. Please reference Alterations in engineering section, page 182.

TAPER-LOCK® bushing is not included with the sprocket. They are to be ordered separately. Please refer to the table below for general guidelines. Specific details are found in the Bushing Section of this catalog beginning on page 164.

TAPER-LOCK® Bushings	
Bushing #	Bore Range
1615	0.500 - 1.688"
2012	0.500 - 2.125"
2517	0.500 - 2.688"
3020	0.875 - 3.250"

# No. 80

## MULTI-STRAND TAPER-LOCK® SPROCKET DIMENSIONS

Tsubaki Stock Sprockets

All dimensions in inches unless noted.

No. 80 Multi-Strand TAPER-LOCK® Sprockets			Dimensional Data Multi-Strand TAPER-LOCK® Sprockets					
No. Teeth	Outside Diameter	Bushing #	Hub Diameter	LTB	MAX Bore *	Hub Type	Hub Style	Weight Lbs.
13	4.660	1615	N/A	1.500	1.688	A	S	3.40
14	4.980	2012	N/A	1.250	2.125	A	S	3.50
15	5.300	2012	N/A	1.250	2.125	A	S	4.30
16	5.630	2517	3.125	1.750	2.688	A	S	3.80
17	5.950	2517	3.125	1.750	2.688	A	S	5.10
18	6.270	2517	3.125	1.750	2.688	A	S	6.40
19	6.590	3020	5.000	2.000	3.250	B	S	5.60
20	6.910	3020	5.250	2.000	3.250	B	S	7.10
21	7.240	3020	5.563	2.000	3.250	B	S	8.90
25	8.520	3020	6.875	2.000	3.250	B	S	16.50
30	10.110	3020	5.250	2.000	3.250	C	S	25.10
36	12.030	3020	5.250	2.000	3.250	C	S	39.40
42	13.940	3020	5.250	2.000	3.250	C	S	36.40
45	14.900	3020	5.250	2.000	3.250	C	S	41.40
52	17.130	3020	5.250	2.000	3.250	C	W	56.20
60	19.680	3020	5.250	2.000	3.250	C	W	66.30

\* Please reference TAPER-LOCK® bushing dimension table on page 165 for specific information on MAX Bore and keyway data.

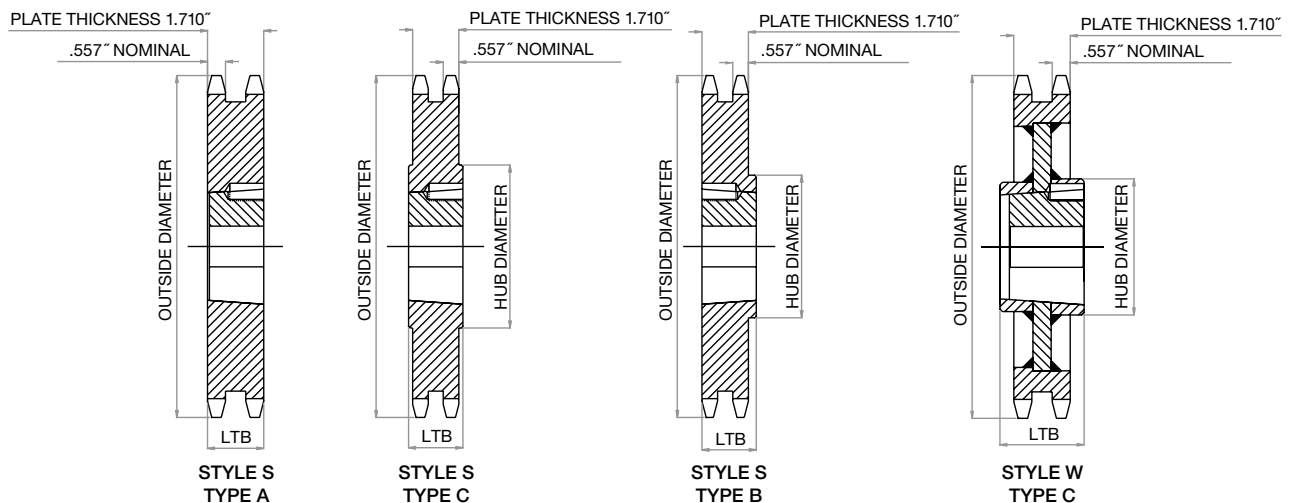

# HOW TO ORDER

TSUBAKI STOCK SPROCKETS



No.  
**80** 1" Pitch: QD®

Chain Data	
Size	80
Pitch	1"
Inside Width	5/8"
Roller Diameter	0.625"
Nominal Tooth Width:	0.575"

How to Order Code: Example Model # for 80 Pitch QD® Carbon Steel Sprockets

<b>A</b>	<b>80</b>	<b>SF</b>	<b>21</b>
----------	-----------	-----------	-----------

Altered <sup>!!</sup>	Chain Pitch in Inches	QD® Hub Type	Number of Teeth				
A: Alteration Required	80: 1" Pitch	SH: QD® Hub 11 - 12 tooth sprocket	11				
			12				
		SDS: QD® Hub 13 - 14 tooth sprocket	13				
			14				
		SK: QD® Hub 15 - 19 tooth sprocket	15	18			
			16	19			
			17				
		SF: QD® Hub 20 - 60 tooth sprocket	20	24	28	36	48
			21	25	30	40	54
			22	26	32	42	60
			23	27	35	45	

<sup>!!</sup>Alteration field only to be denoted if a deviation from standard is required. Please reference Alterations in engineering section, page 182.

QD® bushing is not included with the sprocket. They are to be ordered separately. Please refer to the table below for general guidelines. Specific details are found in the Bushing Section of this catalog beginning on page 170.

QD® Bushings	
Bushing #	Bore Range
SH	0.500 - 1.688"
SDS	0.500 - 2.000"
SK	0.500 - 2.625"
SF	0.500 - 2.938"

# No. 80

## QD® SPROCKET DIMENSIONS

Tsubaki Stock Sprockets

All dimensions in inches unless noted.

No. 80 QD® Sprockets			Dimensional Data QD® Sprockets									
No. Teeth	Outside Dia.	QD® Bushing #	MAX Bore*	Hub Dia.	LTB	X	Y	L	F	Hub Type	Hub Style	Weight Lbs.
11	4.010	SH	1.688	2.688	0.813	1.437	1.437	0.656	2.688	B	S	1.00
12	4.330	SH	1.688	2.750	0.813	1.437	1.437	0.656	2.688	B	S	1.40
13	4.660	SDS	2.000	3.188	0.750	1.500	1.500	0.734	3.188	B	S	1.50
14	4.980	SDS	2.000	3.375	0.750	1.500	1.500	0.734	3.188	B	S	1.80
15	5.300	SK	2.625	3.875	1.250	2.125	2.125	1.297	3.875	B	S	2.50
16	5.630	SK	2.625	4.125	1.250	2.125	2.125	1.297	3.875	B	S	3.10
17	5.950	SK	2.625	4.375	1.250	2.125	2.125	1.297	3.875	B	S	3.50
18	6.270	SK	2.625	4.375	1.250	2.125	2.125	1.297	3.875	B	S	3.90
19	6.590	SK	2.625	4.375	1.250	2.125	2.125	1.297	3.875	B	S	4.40
20	6.910	SF	2.938	5.000	1.250	2.250	2.250	1.422	4.625	B	S	5.30
21	7.240	SF	2.938	5.000	1.250	2.250	2.250	1.422	4.625	B	S	5.70
22	7.560	SF	2.938	5.000	1.250	2.250	2.250	1.422	4.625	B	S	6.30
23	7.880	SF	2.938	5.000	1.250	2.250	2.250	1.422	4.625	B	E	6.80
24	8.200	SF	2.938	5.000	1.250	2.250	2.250	1.422	4.625	B	E	7.50
25	8.520	SF	2.938	5.000	1.250	2.250	2.250	1.422	4.625	B	E	8.00
26	8.840	SF	2.938	5.000	1.250	2.250	2.250	1.422	4.625	B	E	8.60
27	9.160	SF	2.938	5.000	1.250	2.250	2.250	1.422	4.625	B	E	9.40
28	9.480	SF	2.938	5.000	1.250	2.250	2.250	1.422	4.625	B	E	10.20
30	10.110	SF	2.938	5.000	1.250	2.250	2.250	1.422	4.625	B	E	11.30
32	10.750	SF	2.938	5.000	1.250	2.250	2.250	1.422	4.625	B	E	13.00
33	11.070	SF	2.938	5.000	1.250	2.250	2.250	1.422	4.625	B	E	13.50
34	11.390	SF	2.938	5.000	1.250	2.250	2.250	1.422	4.625	B	E	14.10
35	11.710	SF	2.938	5.000	1.250	2.250	2.250	1.422	4.625	B	E	15.50
36	12.030	SF	2.938	5.000	1.250	2.250	2.250	1.422	4.625	B	E	16.90
40	13.310	SF	2.938	5.000	1.250	2.250	2.250	1.422	4.625	B	E	20.60
42	13.940	SF	2.938	5.000	1.250	2.250	2.250	1.422	4.625	B	E	22.40
45	14.900	SF	2.938	5.000	1.250	2.250	2.250	1.422	4.625	B	E	25.10
48	15.860	SF	2.938	5.000	1.250	2.250	2.250	1.422	4.625	B	E	28.60
54	17.770	SF	2.938	5.000	1.250	2.250	2.250	1.422	4.625	B	E	36.80
60	19.680	SF	2.938	5.000	1.250	2.250	2.250	1.422	4.625	B	E	45.80

\* Please reference QD® bushing dimension table on page 171 for specific information on MAX Bore and keyway data.

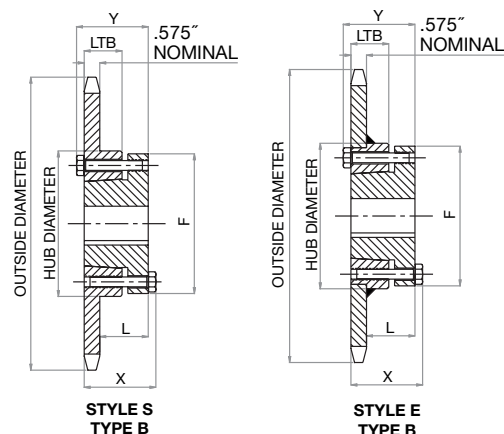



# HOW TO ORDER

TSUBAKI STOCK SPROCKETS



No.  
**100**

**1 1/4" Pitch:  
PLAIN BORE**

Chain Data	
Size	100
Pitch	1 1/4"
Inside Width	3/4"
Roller Diameter	0.750"
Nominal Tooth Width:	0.692"

How to Order Code: Example Model # for 100 Pitch Plain Bore Carbon Steel Sprockets

<b>A</b>	<b>100</b>	<b>B</b>	<b>36</b>
----------	------------	----------	-----------

Altered <sup>1</sup>	Chain Pitch in Inches	Hub Type	Number of Teeth				
			8	16	24	36	72
A: Alteration Required	100: 1 1/4" Pitch	A: No Hub Extension	9	17	25	40	80
			10	18	26	42	84
			11	19	27	45	90
			12	20	28	48	96
			13	21	30	54	
			14	22	32	60	
			15	23	35	70	
			15	23	35	70	
		B: Hub Extension One Side	8	16	24	36	
			9	17	25	40	
			10	18	26	42	
			11	19	27	45	
			12	20	28	48	
			13	21	30		
			14	22	32		
C: Hub Extension Both Sides	54	72	90				
	60	80	96				
	70	84					

<sup>1</sup> Alteration field only to be denoted if a deviation from standard is required. Please reference Alterations in engineering section, page 182.

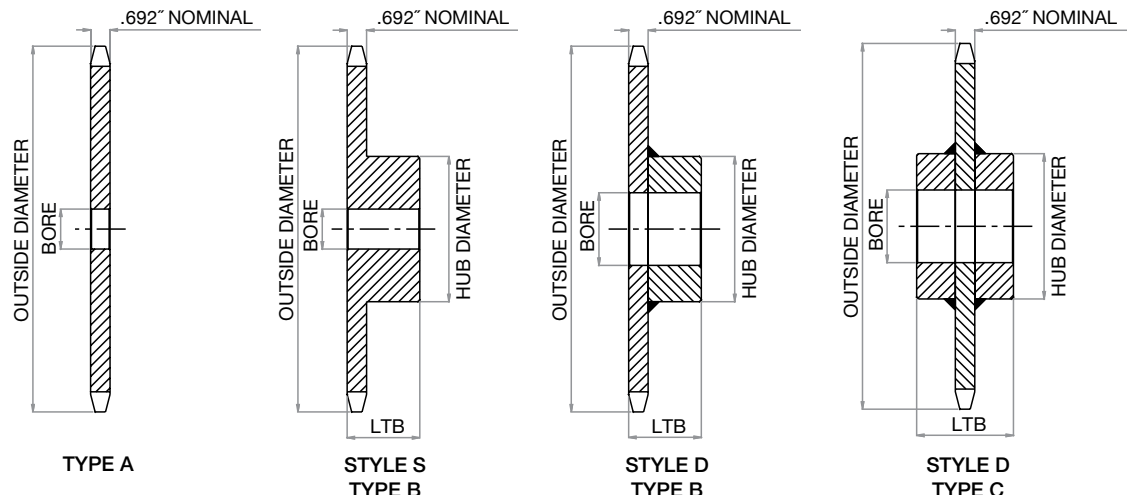

# No. 100

## PLAIN BORE SPROCKET DIMENSIONS

Tsubaki Stock Sprockets

All dimensions in inches unless noted.

No. 100 Plain Bore Sprocket Dia.				Type "A" Plain Bore		Type "B" & "C" Plain Bore						
No. Teeth	Outside Dia.	Pitch Dia.	Caliper Dia.	Plain Bore	Wt. Lbs.	Plain Bore	MAX Bore*	Hub Dia.	LTB	Hub Type	Hub Style	Wt. Lbs.
8	3.770	3.266	2.516	1.000	1.40	1.000	1.250	2.438 "	1.875	B	S	2.30
9	4.180	3.655	2.849	1.000	1.60	1.000	1.625	2.813 "	1.875	B	S	3.20
10	4.600	4.045	3.295	1.000	2.00	1.000	1.875	3.250 "	1.875	B	S	4.10
11	5.010	4.438	3.642	1.250	2.50	1.000	2.250	3.563 "	1.875	B	S	5.30
12	5.420	4.830	4.080	1.250	3.00	1.000	2.250	4.000 "	1.875	B	S	6.40
13	5.820	5.224	4.435	1.250	3.50	1.000	2.375	3.875	1.625	B	S	6.50
14	6.230	5.618	4.868	1.250	4.10	1.250	2.750	4.188	1.625	B	S	7.40
15	6.630	6.013	5.229	1.250	4.70	1.250	3.000	4.500	1.750	B	D	9.20
16	7.030	6.408	5.658	1.250	5.40	1.313	3.000	4.500	1.750	B	D	9.90
17	7.440	6.803	6.024	1.250	6.10	1.313	3.000	4.500	1.750	B	D	10.80
18	7.840	7.199	6.449	1.250	7.00	1.313	3.000	4.500	1.750	B	D	11.50
19	8.240	7.595	6.819	1.250	7.80	1.313	3.000	4.500	2.000	B	D	13.10
20	8.640	7.990	7.240	1.250	8.80	1.313	3.000	4.500	2.000	B	D	14.20
21	9.040	8.388	7.613	1.250	9.80	1.313	3.000	4.500	2.000	B	D	15.30
22	9.440	8.784	8.034	1.250	10.50	1.313	3.000	4.500	2.000	B	D	16.10
23	9.840	9.180	8.409	1.250	11.80	1.250	3.000	4.500	2.000	B	D	17.20
24	10.250	9.576	8.826	1.250	12.80	1.250	3.000	4.500	2.000	B	D	19.20
25	10.660	9.974	9.204	1.250	13.90	1.250	3.000	4.500	2.000	B	D	19.50
26	11.050	10.370	9.620	1.250	15.00	1.250	3.313	5.000	2.000	B	D	21.70
27	11.440	10.768	9.999	1.250	16.00	1.250	3.313	5.000	2.000	B	D	23.00
28	11.840	11.164	10.414	1.250	17.40	1.250	3.313	5.000	2.000	B	D	24.40
30	12.640	11.959	11.209	1.250	20.10	1.250	3.313	5.000	2.000	B	D	26.90
32	13.440	12.753	12.003	1.250	22.60	1.250	3.313	5.000	2.000	B	D	29.80
35	14.640	13.945	13.181	1.250	27.20	1.250	3.313	5.000	2.500	B	D	36.90
36	15.040	14.343	13.593	1.250	30.00	1.250	3.313	5.000	2.500	B	D	38.60
40	16.630	15.933	15.183	1.250	36.00	1.250	3.313	5.000	2.500	B	D	46.90
42	17.430	16.728	15.978	1.250	40.00	1.250	3.313	5.000	2.500	B	D	50.40
45	18.630	17.920	17.159	1.500	47.00	1.500	3.313	5.000	2.500	B	D	54.00
48	19.820	19.113	18.363	1.500	54.00	1.500	4.000	6.000	2.500	B	D	66.00
54	22.210	21.498	20.748	1.500	68.00	1.500	4.000	6.000	3.250	C	D	78.00
60	24.600	23.884	23.134	1.500	80.00	1.500	4.000	6.000	3.250	C	D	89.00
70	28.580	27.861	27.111	1.500	113.00	1.500	5.250	7.000	3.750	C	D	125.00
72	29.380	28.657	27.908	1.500	119.00	1.500	5.250	7.000	3.750	C	D	134.00
80	32.570	31.839	31.089	1.500	146.00	1.500	5.250	7.000	3.750	C	D	151.00
84	34.160	33.430	32.680	1.500	162.00	1.500	5.250	7.000	3.750	C	D	170.00
90	36.550	35.817	35.068	1.500	193.00	1.500	5.250	7.000	3.750	C	D	184.00
96	38.930	38.204	37.454	1.500	215.00	1.500	5.250	7.000	4.500	C	D	203.00

\* Dimensions shown allow for standard keyway with set screw at 90 degrees

" Has recessed groove in hub for chain clearance

# HOW TO ORDER

TSUBAKI STOCK SPROCKETS



No.  
**100**

**1 1/4" Pitch:  
FINISHED BORE**

Chain Data	
Size	100
Pitch	1 1/4"
Inside Width	3/4"
Roller Diameter	0.750"
Nominal Tooth Width:	0.692"

How to Order Code: Example Model # for 100 Pitch Finished Bore Carbon Steel Sprockets

<b>100</b>	<b>B</b>	<b>17</b>	<b>F -</b>	<b>2R</b>
------------	----------	-----------	------------	-----------

Chain Pitch in Inches	Hub Type	Number of Teeth		Finished Bore	Hub Bore**		
100: 1 1/4" Pitch	B: Hub Extension One Side	8	17	F: Hub Extension Machined with keyway and two set screws	1	1"	(1.000")
		9	18		1C	1-3/16"	(1.188")
		10	19		1D	1-1/4"	(1.250")
		11	20		1G	1-7/16"	(1.438")
		12	21		1R	1-15/16"	(1.938")
		13	22		2	2"	(2.000")
		14	23		2C	2-3/16"	(2.188")
		15	24		2G	2-7/16"	(2.438")
		16	25		2R	2-15/16"	(2.938")

\*\* Hub bore size should be selected from dimensional table on the following page. Bore sizes that are not listed for a given # of sprocket teeth may be available per request as Altered.

All dimensions in inches unless noted.

No. 100 Finished Bore Sprocket Dia.				Type "F" Bored to Shaft Size (includes standard keyway and two set screws)								
No. Teeth	Outside Dia.	Pitch Dia.	Caliper Dia.	1.000"	1.188"	1.250"	1.438"	1.938"	2.000"	2.188"	2.438"	2.938"
8	3.770	3.266	2.516	•	•	•						
9	4.180	3.655	2.849	•	•	•	•					
10	4.600	4.045	3.295	•	•	•	•					
11	5.010	4.438	3.642	•	•	•	•	•	•	•		
12	5.420	4.830	4.080	•	•	•	•	•	•	•		
13	5.820	5.224	4.435	•	•	•	•	•	•	•		
14	6.230	5.618	4.868			•	•	•	•	•		
15	6.630	6.013	5.229			•	•	•	•	•		
16	7.030	6.408	5.658				•	•	•	•	•	•
17	7.440	6.803	6.024				•	•	•	•	•	•
18	7.840	7.199	6.449				•	•	•	•	•	•
19	8.240	7.595	6.819				•	•	•	•	•	•
20	8.640	7.990	7.240				•	•	•	•	•	•
21	9.040	8.388	7.613				•	•	•	•	•	•
22	9.440	8.784	8.034				•	•	•	•	•	•
23	9.840	9.180	8.409				•	•	•	•	•	•
24	10.250	9.576	8.826				•	•	•	•	•	•
25	10.660	9.974	9.204				•	•	•	•	•	•

• Denotes stocking item

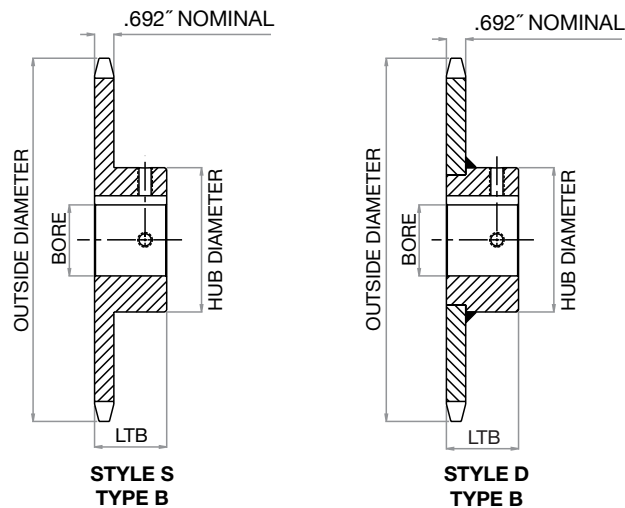

# HOW TO ORDER

TSUBAKI STOCK SPROCKETS



No.  
100

1 1/4" Pitch:  
MULTI-STRAND

Chain Data	
Size	100-2, 100-3
Pitch	1 1/4"
Inside Width	3/4"
Roller Diameter	0.750"
Nominal Tooth Width	0.669"

How to Order Code: Example Model # for 100 Pitch Multi-Strand Carbon Steel Sprockets

<b>A</b>	<b>D</b>	<b>100</b>	<b>B</b>	<b>25</b>
----------	----------	------------	----------	-----------

Altered <sup>1</sup>	Multi	Chain Pitch in Inches	Hub Type	Number of Teeth				
A: Alteration Required	D: Double Strand	100: 1 1/4" Pitch	B: Hub Extension One Side	Double Strand				
				9	14	19	24	35
				10	15	20	25	36
				11	16	21	26	
				12	17	22	30	
	13			18	23	32		
	Triple Strand							
	12			16	20	24		
	13			17	21	25		
	14			18	22	26		
15	19	23	30					

<sup>1</sup> Alteration field only to be denoted if a deviation from standard is required. Please reference Alterations in engineering section, page 182.

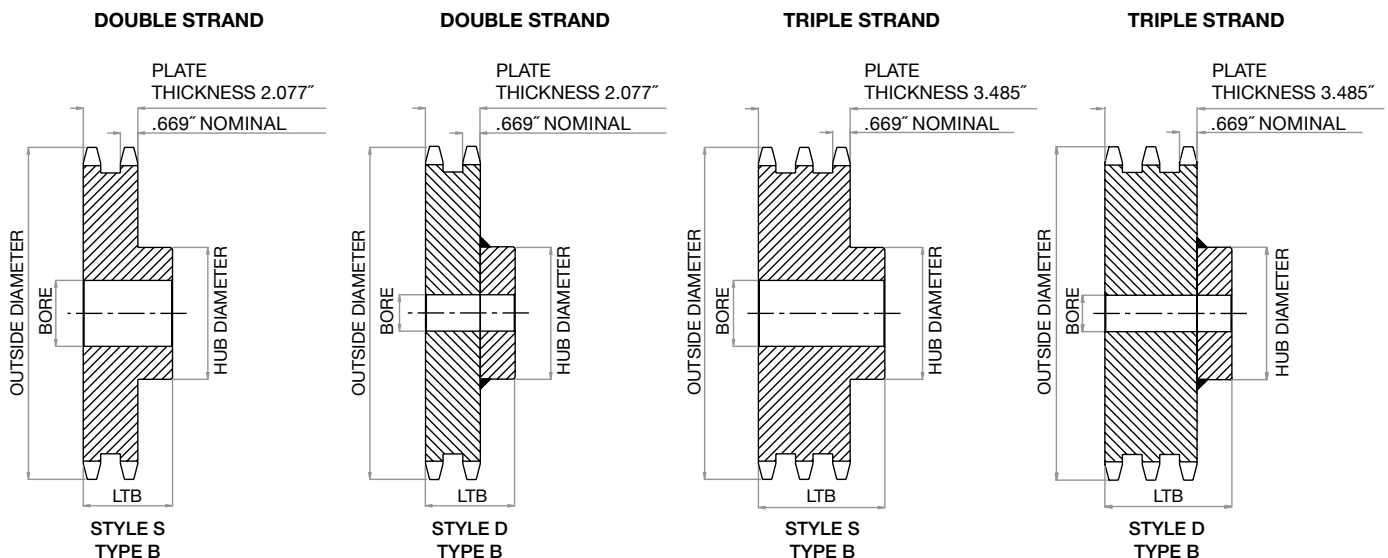

# No. 100

## MULTI-STRAND SPROCKET DIMENSIONS

Tsubaki Stock Sprockets

All dimensions in inches unless noted.

No. 100 Multi-Strand Sprocket Dia.			Dimensional Data: Double Strand Sprockets					
No. Teeth	Outside Diameter	Plain Bore	Hub Diameter	LTB	MAX Bore*	Hub Type	Hub Style	Weight Lbs.
9	4.180	1.000	2.375	2.875	1.625	B	S	4.60
10	4.600	1.000	2.375	2.875	1.875	B	S	6.20
11	5.010	1.000	3.125	2.875	2.125	B	S	7.90
12	5.420	1.125	3.375	2.875	2.250	B	S	9.30
13	5.820	1.125	3.813	2.875	2.500	B	S	11.40
14	6.230	1.125	4.188	2.875	2.750	B	S	13.60
15	6.630	1.250	4.625	3.125	3.125	B	S	17.10
16	7.030	1.250	5.000	3.125	3.313	B	S	20.10
17	7.440	1.250	5.250	3.125	3.500	B	S	23.10
18	7.840	1.250	5.250	3.125	3.500	B	S	25.40
19	8.240	1.250	5.500	3.375	3.750	B	S	29.60
20	8.640	1.250	5.500	3.375	3.750	B	S	32.40
21	9.040	1.250	5.500	3.375	3.750	B	S	35.30
22	9.440	1.250	5.500	3.375	3.750	B	D	38.40
23	9.840	1.250	5.500	3.375	3.750	B	D	41.30
24	10.250	1.250	5.750	3.375	3.750	B	D	45.10
25	10.660	1.250	5.750	3.375	3.750	B	D	48.50
26	11.050	1.500	5.750	3.375	3.750	B	D	51.50
30	12.640	1.500	5.750	3.375	3.750	B	D	65.00
32	13.440	1.500	5.750	3.375	3.750	B	D	69.00
35	14.640	1.500	6.000	4.250	3.813	B	D	75.00
36	15.038	1.500	6.000	4.500	4.000	B	D	90.80

\* Dimensions shown allow for standard keyway with set screw at 90 degrees

All dimensions in inches unless noted.

No. 100 Multi-Strand Sprocket Dia.			Dimensional Data: Triple Strand Sprockets					
No. Teeth	Outside Diameter	Plain Bore	Hub Diameter	LTB	MAX Bore*	Hub Type	Hub Style	Weight Lbs.
12	5.420	1.125	3.375	4.250	2.250	B	S	13.70
13	5.820	1.125	3.813	4.250	2.500	B	S	16.90
14	6.230	1.125	4.188	4.250	2.750	B	S	20.20
15	6.630	1.250	4.625	4.500	3.125	B	S	25.00
16	7.030	1.250	5.000	4.500	3.313	B	S	29.30
17	7.440	1.250	5.250	4.500	3.500	B	S	33.80
18	7.840	1.250	5.250	4.750	3.500	B	S	38.60
19	8.240	1.250	5.500	4.750	3.750	B	D	43.30
20	8.640	1.250	5.500	4.750	3.750	B	D	47.90
21	9.040	1.250	5.500	4.750	3.750	B	D	52.30
22	9.440	1.250	5.500	4.750	3.750	B	D	57.50
23	9.840	1.250	5.500	4.750	3.750	B	D	62.50
24	10.250	1.250	5.750	4.750	3.750	B	D	69.00
25	10.660	1.250	5.750	4.750	3.750	B	D	73.00
26	11.050	1.500	5.750	4.750	3.813	B	D	79.00
30	12.640	1.500	5.750	4.750	3.813	B	D	103.00

\* Dimensions shown allow for standard keyway with set screw at 90 degrees

# HOW TO ORDER

TSUBAKI STOCK SPROCKETS



No.  
**100**

**1 1/4" Pitch:  
DOUBLE SINGLE**

Chain Data	
Size	100
Pitch	1 1/4"
Inside Width	3/4"
Roller Diameter	0.750"
Nominal Tooth Width:	0.692"

How to Order Code: Example Model # for 100 Pitch Double Single Carbon Steel Sprockets

<b>A</b>	<b>DS</b>	<b>100</b>	<b>A</b>	<b>19</b>																				
Altered <sup>!!</sup>	Multi	Chain Pitch in Inches	Hub Type	Number of Teeth																				
A: Alteration Required	DS: Double Single	100: 1 1/4" Pitch	A: No Hub Extension	<table border="1"> <tr> <td>13</td> <td>17</td> <td>21</td> <td></td> <td></td> </tr> <tr> <td>14</td> <td>18</td> <td></td> <td></td> <td></td> </tr> <tr> <td>15</td> <td>19</td> <td></td> <td></td> <td></td> </tr> <tr> <td>16</td> <td>20</td> <td></td> <td></td> <td></td> </tr> </table>	13	17	21			14	18				15	19				16	20			
13	17	21																						
14	18																							
15	19																							
16	20																							

<sup>!!</sup>Alteration field only to be denoted if a deviation from standard is required. Please reference Alterations in engineering section, page 182.

How to Order Code: Example Model # for 100 Pitch Double Single TAPER-LOCK<sup>®</sup> Carbon Steel Sprockets

<b>A</b>	<b>DS</b>	<b>100</b>	<b>A</b>	<b>TL</b>	<b>19</b>																				
Altered <sup>!!</sup>	Multi	Chain Pitch in Inches	Hub Type	TAPER-LOCK <sup>®</sup>	Number of Teeth																				
A: Alteration Required	DS: Double Single	100: 1 1/4" Pitch	A: No Hub Extension	TAPER-LOCK <sup>®</sup> hub with set screws	<table border="1"> <tr> <td>16</td> <td>20</td> <td></td> <td></td> <td></td> </tr> <tr> <td>17</td> <td>21</td> <td></td> <td></td> <td></td> </tr> <tr> <td>18</td> <td></td> <td></td> <td></td> <td></td> </tr> <tr> <td>19</td> <td></td> <td></td> <td></td> <td></td> </tr> </table>	16	20				17	21				18					19				
16	20																								
17	21																								
18																									
19																									

<sup>!!</sup>Alteration field only to be denoted if a deviation from standard is required. Please reference Alterations in engineering section, page 182.

TAPER-LOCK<sup>®</sup> bushing is not included with the sprocket. They are to be ordered separately. Please refer to the table below for general guidelines. Specific details are found in the Bushing Section of this catalog beginning on page 164.

TAPER-LOCK <sup>®</sup> Bushings	
Bushing #	Bore Range
2517	0.500 - 2.688"
3020	0.8750 - 3.250"

All dimensions in inches unless noted.

No. 100 Double Single Sprocket Diameters			Dimensional Data: Double Single Sprockets				
No. Teeth	Outside Dia.	Plain Bore	LTB	C	D	MAX Bore *	Weight Lbs.
13	5.820	1.000	2.688	2.000	3.781	2.500	11.20
14	6.230	1.250	2.688	2.000	4.188	2.750	13.50
15	6.630	1.250	2.688	2.000	4.594	3.063	16.80
16	7.030	1.250	2.688	2.000	4.500	3.250	19.30
17	7.440	1.250	2.688	2.000	4.906	3.625	21.50
18	7.840	1.250	2.688	2.000	5.281	3.750	23.00
19	8.240	1.250	2.688	2.000	6.203	4.188	25.00
20	8.640	1.250	2.688	2.000	6.609	4.813	26.50
21	9.040	1.250	2.688	2.000	7.000	5.250	29.00

\* Dimensions shown allow for standard keyway with set screw at 90 degrees

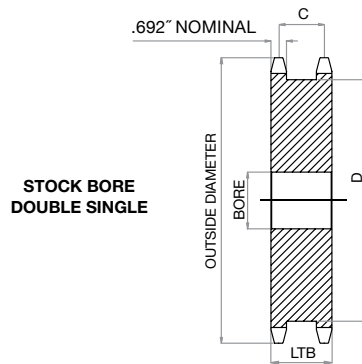

All dimensions in inches unless noted.

No. 100 Double Single TAPER-LOCK® Sprocket Diameters			Dimensional Data: Double Single TAPER-LOCK® Sprockets				
No. Teeth	Outside Dia.	Bushing #	LTB	C	D	MAX Bore *	Weight Lbs.
16	7.030	2517	2.688	2.000	5.000	2.688	13.00
17	7.440	3020	2.688	2.000	5.469	3.250	14.00
18	7.840	3020	2.688	2.000	5.797	3.250	16.00
19	8.240	3020	2.688	2.000	6.203	3.250	20.00
20	8.640	3020	2.688	2.000	6.906	3.250	24.00
21	9.040	3020	2.688	2.000	7.000	3.250	27.50

\* Please reference TAPER-LOCK® bushing dimension table on page 165 for specific information on MAX Bore and keyway data.

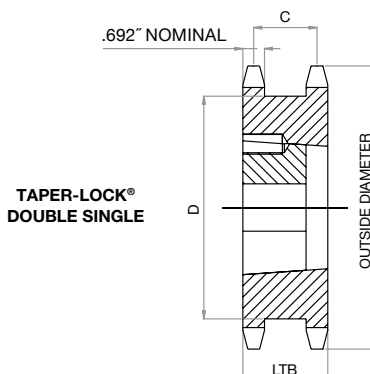



# HOW TO ORDER

TSUBAKI STOCK SPROCKETS



No.  
**100**

**1 1/4" Pitch:  
TAPER-LOCK®**

Chain Data	
Size	100
Pitch	1 1/4"
Inside Width	3/4"
Roller Diameter	0.750"
Nominal Tooth Width:	0.692"

How to Order Code: Example Model # for 100 Pitch TAPER-LOCK® Carbon Steel Sprockets

<b>A</b>	<b>100</b>	<b>B</b>	<b>TL</b>	<b>18</b>				
Altered <sup>¶</sup>	Chain Pitch in Inches	Hub Type	TAPER-LOCK®	Number of Teeth				
A: Alteration Required	100: 1 1/4" Pitch	B: Hub Extension One Side	TAPER-LOCK® hub with set screws	11	18	28		
				12	19	30		
				13	20	32		
				14	21	35		
				15	22	36		
				16	24	40		
				17	26			

<sup>¶</sup>Alteration field only to be denoted if a deviation from standard is required. Please reference Alterations in engineering section, page 182.

TAPER-LOCK® bushing is not included with the sprocket. They are to be ordered separately. Please refer to the table below for general guidelines. Specific details are found in the Bushing Section of this catalog beginning on page 164.

TAPER-LOCK® Bushings	
Bushing #	Bore Range
1615	0.500 - 1.688"
2012	0.500 - 2.125"
2517	0.500 - 2.688"
3020	0.875 - 3.250"

All dimensions in inches unless noted.

No. 100 TAPER-LOCK® Sprockets			Dimensional Data TAPER-LOCK® Sprockets					
No. Teeth	Outside Diameter	Bushing #	Hub Diameter	LTB	MAX Bore *	Hub Type	Hub Style	Weight Lbs.
11	5.010	1615	3.000	1.500	1.688	B	S	2.70
12	5.420	1615	3.250	1.500	1.688	B	S	3.50
13	5.820	2012	3.563	1.250	2.125	B	S	3.60
14	6.230	2012	3.563	1.250	2.125	B	S	3.90
15	6.630	2517	4.250	1.750	2.688	B	S	5.00
16	7.030	2517	4.500	1.750	2.688	B	E	6.40
17	7.440	2517	4.500	1.750	2.688	B	E	7.10
18	7.840	2517	4.500	1.750	2.688	B	E	7.80
19	8.240	2517	4.500	1.750	2.688	B	E	8.70
20	8.640	2517	4.500	1.750	2.688	B	E	9.60
21	9.040	2517	4.500	1.750	2.688	B	E	10.60
22	9.440	2517	4.500	1.750	2.688	B	E	11.00
24	10.250	2517	4.500	1.750	2.688	B	E	13.00
26	11.050	2517	5.250	1.750	2.688	B	E	15.00
28	11.840	3020	5.250	2.000	3.250	B	E	16.50
30	12.640	3020	5.250	2.000	3.250	B	E	22.00
32	13.440	3020	5.250	2.000	3.250	B	E	23.00
35	14.640	3020	5.250	2.000	3.250	B	E	28.00
36	15.040	3020	5.250	2.000	3.250	B	E	31.00
40	16.630	3020	5.250	2.000	3.250	B	E	37.00

\* Please reference TAPER-LOCK® bushing dimension table on page 165 for specific information on MAX Bore and keyway data.

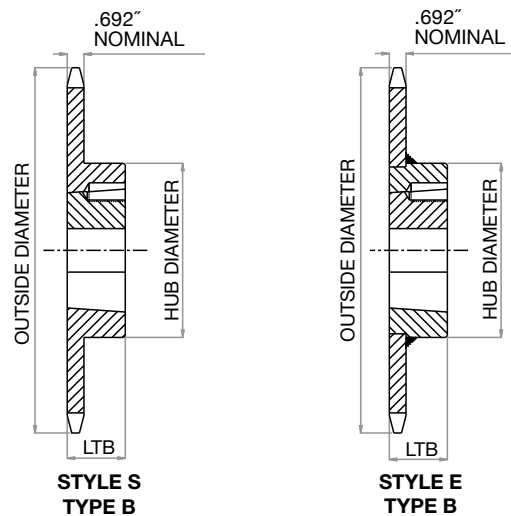

# HOW TO ORDER

TSUBAKI STOCK SPROCKETS



No.  
**100**

**1 1/4" Pitch: QD®**

Chain Data	
Size	100
Pitch	1 1/4"
Inside Width	3/4"
Roller Diameter	0.750"
Nominal Tooth Width:	0.692"

How to Order Code: Example Model # for 100 Pitch QD® Carbon Steel Sprockets

<b>A</b>	<b>100</b>	<b>SF</b>	<b>17</b>
----------	------------	-----------	-----------

Altered <sup>‡</sup>	Chain Pitch in Inches	QD® Hub Type	Number of Teeth				
A: Alteration Required	100: 1 1/4" Pitch	SDS: QD® Hub 11 - 12 tooth sprocket	11				
			12				
		SK: QD® Hub 13 - 14 tooth sprocket	13				
			14				
		SF: QD® Hub 15 - 17 tooth sprocket	15				
			16				
			17				
		E: QD® Hub 18 - 60 tooth sprocket	18	22	26	32	42
			19	23	27	35	45
			20	24	28	36	48
			21	25	30	40	54
							60

<sup>‡</sup> Alteration field only to be denoted if a deviation from standard is required. Please reference Alterations in engineering section, page 182.

QD® bushing is not included with the sprocket. They are to be ordered separately. Please refer to the table below for general guidelines. Specific details are found in the Bushing Section of this catalog beginning on page 170.

QD® Bushings	
Bushing #	Bore Range
SDS	0.500 - 2.000"
SK	0.500 - 2.625"
SF	0.500 - 2.938"
E	0.875 - 3.500"

All dimensions in inches unless noted.

No. 100 QD® Sprockets			Dimensional Data QD® Sprockets									
No. Teeth	Outside Dia.	QD® Bushing #	MAX Bore*	Hub Dia.	LTB	X	Y	L	F	Hub Type	Hub Style	Weight Lbs.
11	5.010	SDS	2.000	3.188	0.750	1.500	1.500	0.625	3.188	B	S	2.00
12	5.420	SDS	2.000	3.500	0.750	1.500	1.500	0.625	3.188	B	S	2.60
13	5.820	SK	2.625	3.938	1.250	2.125	2.125	1.203	3.875	B	S	3.30
14	6.230	SK	2.625	4.250	1.250	2.125	2.125	1.203	3.875	B	S	4.10
15	6.630	SF	2.938	4.625	1.250	2.250	2.250	1.234	4.625	B	S	4.80
16	7.030	SF	2.938	5.000	1.250	2.250	2.250	1.234	4.625	B	S	5.60
17	7.440	SF	2.938	5.000	1.250	2.250	2.250	1.234	4.625	B	S	6.50
18	7.840	E	3.500	6.250	1.625	2.938	2.625	1.813	6.000	B1	S	9.00
19	8.240	E	3.500	6.250	1.625	2.938	2.625	1.813	6.000	B1	S	10.20
20	8.640	E	3.500	6.250	1.625	2.938	2.625	1.813	6.000	B1	S	11.60
21	9.040	E	3.500	6.250	1.625	2.938	2.625	1.813	6.000	B1	S	12.50
22	9.440	E	3.500	6.250	1.625	2.938	2.625	1.813	6.000	B1	E	13.50
23	9.840	E	3.500	6.250	1.625	2.938	2.625	1.813	6.000	B1	E	14.60
24	10.250	E	3.500	6.250	1.625	2.938	2.625	1.813	6.000	B1	E	15.70
25	10.660	E	3.500	6.250	1.625	2.938	2.625	1.813	6.000	B1	E	16.80
26	11.050	E	3.500	6.250	1.625	2.938	2.625	1.813	6.000	B1	E	18.10
27	11.440	E	3.500	6.250	1.625	2.938	2.625	1.813	6.000	B1	E	19.20
28	11.840	E	3.500	6.250	1.625	2.938	2.625	1.813	6.000	B1	E	20.70
30	12.640	E	3.500	6.250	1.625	2.938	2.625	1.813	6.000	B1	E	23.20
32	13.440	E	3.500	6.250	1.625	2.938	2.625	1.813	6.000	B1	E	25.40
35	14.640	E	3.500	6.250	1.625	2.938	2.625	1.813	6.000	B1	E	30.50
36	15.040	E	3.500	6.250	1.625	2.938	2.625	1.813	6.000	B1	E	32.30
40	16.630	E	3.500	6.250	1.625	2.938	2.625	1.813	6.000	B1	E	39.10
42	17.430	E	3.500	6.250	1.625	2.938	2.625	1.813	6.000	B1	E	43.40
45	17.920	E	3.500	6.250	1.625	2.958	2.625	1.813	6.000	B1	E	48.90
48	19.112	E	3.500	6.250	1.625	2.958	2.625	1.813	6.000	B1	E	54.00
54	21.498	E	3.500	6.250	1.625	2.958	2.625	1.813	6.000	B1	E	62.00
60	23.884	E	3.500	6.250	1.625	2.958	2.625	1.813	6.000	B1	E	74.00

\* Please reference QD® bushing dimension table on page 171 for specific information on MAX Bore and keyway data.

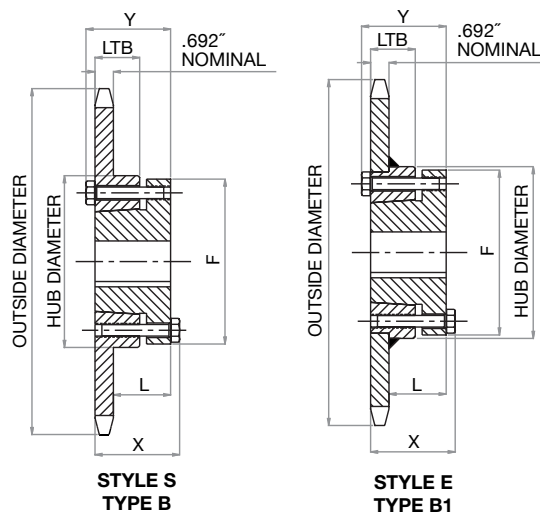

# HOW TO ORDER

TSUBAKI STOCK SPROCKETS



No.  
**120**

**1 1/2" Pitch:  
PLAIN BORE**

Chain Data	
Size	120
Pitch	1 1/2"
Inside Width	1.00"
Roller Diameter	0.875"
Nominal Tooth Width:	0.924"

How to Order Code: Example Model # for 120 Pitch Plain Bore Carbon Steel Sprockets

<b>A</b>	<b>120</b>	<b>B</b>	<b>17</b>
----------	------------	----------	-----------

Altered <sup>¶</sup>	Chain Pitch in Inches	Hub Type	Number of Teeth					
A: Alteration Required	120: 1 1/2" Pitch	A: No Hub Extension	9	16	23	32	54	
			10	17	24	35	60	
			11	18	25	36	70	
			12	19	26	40	80	
			13	20	27	42		
			14	21	28	45		
			15	22	30	48		
		B: Hub Extension One Side	9	16	23	32		
			10	17	24	35		
			11	18	25	36		
			12	19	26			
			13	20	27			
			14	21	28			
		C: Hub Extension Both Sides	15	22	30			
			40	54				
			42	60				
			45	70				
				48	80			

<sup>¶</sup> Alteration field only to be denoted if a deviation from standard is required. Please reference Alterations in engineering section, page 182.

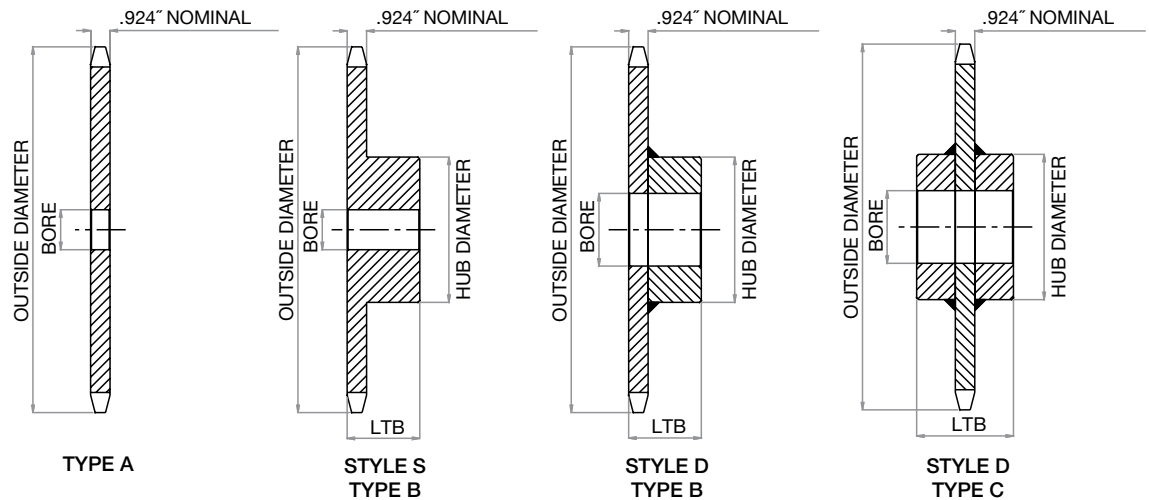

# No. 120

## PLAIN BORE SPROCKET DIMENSIONS

Tsubaki Stock Sprockets

All dimensions in inches unless noted.

No. 120 Plain Bore Sprocket Dia.				Type "A" Plain Bore		Type "B" & "C" Plain Bore						
No. Teeth	Outside Dia.	Pitch Dia.	Caliper Dia.	Plain Bore	Wt. Lbs.	Plain Bore	MAX Bore *	Hub Dia.	LTB	Hub Type	Hub Style	Wt. Lbs.
9	5.020	4.386	3.444	1.250	3.00	1.375	1.813	3.375 "	2.250	B	S	5.30
10	5.520	4.854	3.979	1.250	3.80	1.375	2.250	3.750 "	2.250	B	S	7.10
11	6.010	5.325	4.395	1.250	4.80	1.375	2.375	3.563	2.125	B	S	7.60
12	6.500	5.796	4.921	1.250	5.80	1.375	2.750	4.125	2.125	B	S	9.90
13	6.990	6.269	5.347	1.250	6.70	1.375	3.000	4.563	2.250	B	S	12.40
14	7.470	6.741	5.866	1.250	8.00	1.375	3.250	4.750	2.250	B	D	14.40
15	7.960	7.215	6.300	1.250	9.10	1.250	3.250	4.750	2.375	B	D	16.70
16	8.440	7.689	6.814	1.250	10.60	1.250	3.500	5.250	2.375	B	D	19.90
17	8.920	8.163	7.254	1.250	12.60	1.250	3.500	5.250	2.375	B	D	20.80
18	9.410	8.639	7.764	1.250	13.60	1.250	3.500	5.250	2.375	B	D	22.20
19	9.890	9.114	8.207	1.250	15.10	1.250	3.500	5.250	2.375	B	D	24.80
20	10.370	9.588	8.713	1.250	16.90	1.250	3.500	5.250	2.375	B	D	25.80
21	10.850	10.065	9.161	1.250	18.70	1.250	3.500	5.250	2.375	B	D	26.70
22	11.330	10.541	9.666	1.250	20.00	1.250	3.500	5.250	2.375	B	D	28.20
23	11.810	11.016	10.115	1.250	22.10	1.250	3.500	5.250	2.375	B	D	30.30
24	12.290	11.492	10.617	1.250	24.80	1.250	3.500	5.250	2.375	B	D	32.10
25	12.770	11.969	11.070	1.250	26.80	1.250	3.500	5.250	2.375	B	D	34.60
26	13.250	12.444	11.569	1.500	28.30	1.500	4.000	6.000	2.500	B	D	40.00
27	13.730	12.921	12.024	1.500	30.90	1.500	4.000	6.000	2.500	B	D	43.15
28	14.210	13.397	12.522	1.500	33.60	1.500	4.000	6.000	2.500	B	D	44.90
30	15.170	14.351	13.476	1.500	39.00	1.500	4.000	6.000	2.500	B	D	50.20
32	16.130	15.303	14.428	1.500	43.90	1.500	4.000	6.000	2.500	B	D	56.00
35	17.570	16.734	15.842	1.500	52.00	1.500	4.000	6.000	2.500	B	D	62.40
36	18.050	17.211	16.336	1.500	56.00	1.500	4.000	6.000	2.500	B	D	66.40
40	19.960	19.119	18.244	1.500	71.00	1.500	4.000	6.000	3.750	C	D	92.00
42	20.920	20.073	19.198	1.500	75.00	1.500	4.000	6.000	3.750	C	D	98.00
45	22.350	21.504	20.615	1.500	88.00	1.500	4.000	6.000	3.750	C	D	99.20
48	23.790	22.935	22.060	1.500	103.00	1.500	4.000	6.000	4.000	C	D	113.00
54	26.650	25.797	24.922	1.500	140.00	1.500	4.000	6.000	4.000	C	D	133.00
60	29.520	28.661	27.786	1.500	160.00	1.500	5.250	7.000	4.000	C	D	160.00
70	34.300	33.434	32.559	1.500	216.00	1.500	5.375	7.500	4.500	C	D	206.00
80	39.080	38.207	37.332	1.500	284.00	1.500	5.375	7.500	4.500	C	D	254.00

\* Dimensions shown allow for standard keyway with set screw at 90 degrees

" Has recessed groove in hub for chain clearance

# HOW TO ORDER

TSUBAKI STOCK SPROCKETS



No.  
**120**

**1½" Pitch:  
MULTI-STRAND**

Chain Data	
Size	120
Pitch	1 1/2"
Inside Width	1.00"
Roller Diameter	0.875"
Nominal Tooth Width:	0.894"

How to Order Code: Example Model # for 120 Pitch Multi-Strand Carbon Steel Sprockets

<b>A</b>	<b>D</b>	<b>120</b>	<b>B</b>	<b>25</b>				
Altered <sup>#</sup>	Multi	Chain Pitch in Inches	Hub Type	Number of Teeth				
A: Alteration Required	D: Double Strand	120: 1½" Pitch	B: Hub Extension One Side	11	15	19	23	30
				12	16	20	24	
				13	17	21	25	
				14	18	22	26	

<sup>#</sup> Alteration field only to be denoted if a deviation from standard is required. Please reference Alterations in engineering section, page 182.

All dimensions in inches unless noted.

No. 120 Multi-Strand Sprocket Dia.			Dimensional Data: Double Strand Sprockets					
No. Teeth	Outside Diameter	Plain Bore	Hub Diameter	LTB	MAX Bore *	Hub Type	Hub Style	Weight Lbs.
11	6.010	1.500	3.563	3.750	2.375	B	S	13.60
12	6.500	1.500	4.063	3.750	2.375	B	S	17.30
13	6.990	1.500	4.500	3.750	3.000	B	S	21.10
14	7.470	1.500	5.000	3.750	3.313	B	S	25.60
15	7.960	1.500	5.250	3.750	3.500	B	S	29.90
16	8.440	1.500	5.250	3.750	3.500	B	S	33.80
17	8.920	1.500	5.250	3.750	3.500	B	S	36.90
18	9.410	1.500	5.250	3.750	3.500	B	S	41.90
19	9.890	1.500	5.250	3.750	3.500	B	S	46.50
20	10.370	1.500	5.500	3.750	3.500	B	S	50.20
21	10.850	1.500	5.500	3.750	3.500	B	S	55.60
22	11.330	1.500	5.750	4.000	3.813	B	S	64.00
23	11.810	1.500	6.500	4.000	4.500	B	S	75.00
24	12.290	1.500	6.500	4.000	4.500	B	D	79.00
25	12.770	1.500	6.500	4.000	4.500	B	D	84.00
26	13.250	1.500	6.500	4.000	4.500	B	D	90.00
30	15.170	1.500	6.500	4.000	4.500	B	D	119.00

\* Dimensions shown allow for standard keyway with set screw at 90 degrees

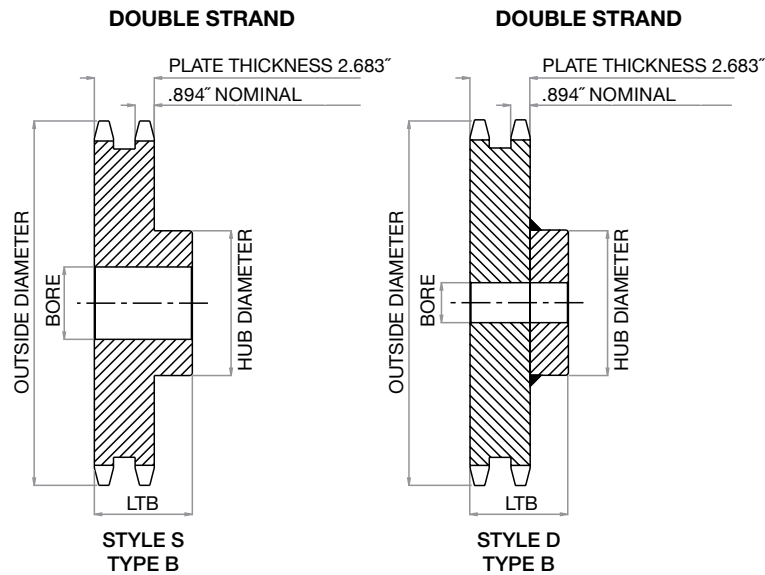



# HOW TO ORDER

TSUBAKI STOCK SPROCKETS



No.  
**120**

**1½" Pitch:  
TAPER-LOCK®**

Chain Data	
Size	120
Pitch	1 1/2"
Inside Width	1.00"
Roller Diameter	0.875"
Nominal Tooth Width:	0.924"

How to Order Code: Example Model # for 120 Pitch TAPER-LOCK® Carbon Steel Sprockets

<b>A</b>	<b>120</b>	<b>B</b>	<b>TL</b>	<b>19</b>				
Altered <sup>‡</sup>	Chain Pitch in Inches	Hub Type	TAPER-LOCK®	Number of Teeth				
A: Alteration Required	120: 1½" Pitch	B: Hub Extension One Side	TAPER-LOCK® hub with set screws	12	17	21		
				14	18	24		
				15	19	26		
		C: Hub Extension Both Sides		16	20	30		
				35	60			
				36	70			
				45	80			

<sup>‡</sup> Alteration field only to be denoted if a deviation from standard is required. Please reference Alterations in engineering section, page 182.

TAPER-LOCK® bushing is not included with the sprocket. They are to be ordered separately. Please refer to the table below for general guidelines. Specific details are found in the Bushing Section of this catalog beginning on page 164.

TAPER-LOCK® Bushings	
Bushing #	Bore Range
2012	0.500 - 2.125"
2517	0.500 - 2.688"
3020	0.875 - 3.250"
3030	0.938 - 3.250"
3535	1.188 - 3.938"

All dimensions in inches unless noted.

No. 120 TAPER-LOCK® Sprockets			Dimensional Data TAPER-LOCK® Sprockets					
No. Teeth	Outside Diameter	Bushing #	Hub Diameter	LTB	MAX Bore *	Hub Type	Hub Style	Weight Lbs.
12	6.500	2012	3.563	1.250	2.125	B	S	5.50
13	6.990	2517	4.250	1.750	2.688	B	S	6.00
14	7.470	2517	4.250	1.750	2.688	B	E	7.00
15	7.960	2517	4.250	1.750	2.688	B	E	8.00
16	8.440	3020	5.250	2.000	3.250	B	E	10.00
17	8.920	3020	5.250	2.000	3.250	B	E	11.00
18	9.410	3020	5.250	2.000	3.250	B	E	12.00
19	9.890	3020	5.250	2.000	3.250	B	E	14.00
20	10.370	3020	5.250	2.000	3.250	B	E	15.50
21	10.850	3020	5.250	2.000	3.250	B	E	17.50
24	12.290	3020	5.250	2.000	3.250	B	E	23.50
26	13.250	3020	5.250	2.000	3.250	B	E	28.50
35	17.570	3020	5.250	2.000	3.250	C	E	33.50
36	18.050	3020	5.250	2.000	3.250	C	E	54.00
45	22.350	3030	5.875	3.000	3.250	C	E	82.00
60	29.520	3535	6.500	3.500	3.938	C	E	140.00
70	34.300	3535	6.500	3.500	3.938	C	E	175.00
80	39.080	3535	6.500	3.500	3.938	C	E	220.00

\* Please reference TAPER-LOCK® bushing dimension table on page 165 for specific information on MAX Bore and keyway data.

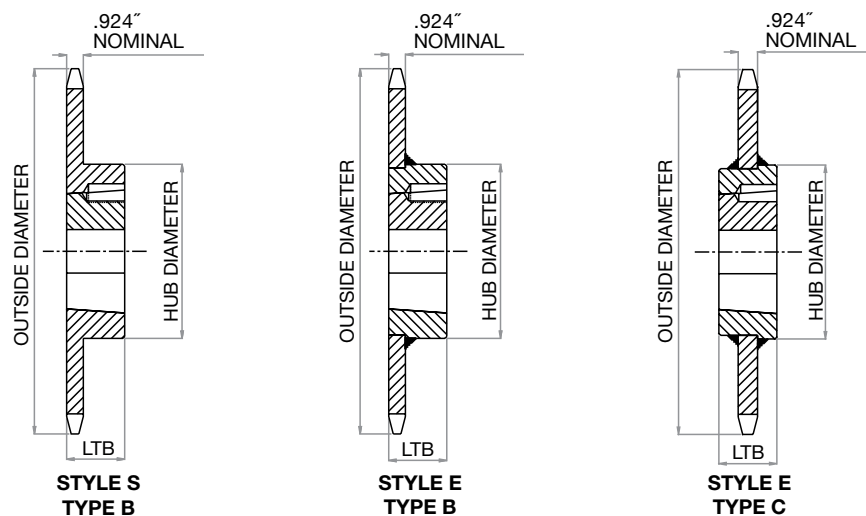

# HOW TO ORDER

TSUBAKI STOCK SPROCKETS



No.  
**120**

**1½" Pitch: QD®**

Chain Data	
Size	120
Pitch	1 1/2"
Inside Width	1.00"
Roller Diameter	0.875"
Nominal Tooth Width:	0.924"

How to Order Code: Example Model # for 120 Pitch QD® Carbon Steel Sprockets

<b>A</b>	<b>120</b>	<b>E</b>	<b>17</b>
----------	------------	----------	-----------

Altered <sup>!!</sup>	Chain Pitch in Inches	QD® Hub Type	Number of Teeth					
A: Alteration Required	120: 1½" Pitch	SF: QD® Hub 12 - 15 tooth sprocket	12	15				
			13					
			14					
		E: QD® Hub 16 - 30 tooth sprocket	16	19	22	25	30	
			17	20	23	26		
			18	21	24	28		
		F: QD® Hub 32 - 54 tooth sprocket	35	42	54			
			36	45				
			40	48				
		J: QD® Hub 60 - 80 tooth sprocket	60					
			70					
			80					

<sup>!!</sup>Alteration field only to be denoted if a deviation from standard is required. Please reference Alterations in engineering section, page 182.

QD® bushing is not included with the sprocket. They are to be ordered separately. Please refer to the table below for general guidelines. Specific details are found in the Bushing Section of this catalog beginning on page 170.

QD® Bushings	
Bushing #	Bore Range
SF	0.500 - 2.938"
E	0.875 - 3.500"
F	1.000 - 4.000"
J	1.500 - 4.500"

# No. 120

## QD® SPROCKET DIMENSIONS

Tsubaki Stock Sprockets

All dimensions in inches unless noted.

No. 120 QD® Sprockets			Dimensional Data QD® Sprockets									
No. Teeth	Outside Dia.	QD® Bushing #	MAX Bore*	Hub Dia.	LTB	X	Y	L	F	Hub Type	Hub Style	Weight Lbs.
12	6.500	SF	2.938	4.375	1.250	2.250	2.250	1.078	4.625	B	S	4.70
13	6.990	SF	2.938	4.625	1.250	2.250	2.250	1.078	4.625	B	S	6.10
14	7.470	SF	2.938	5.000	1.250	2.250	2.250	1.078	4.625	B	S	7.40
15	7.960	SF	2.938	5.000	1.250	2.250	2.250	1.078	4.625	B	S	8.00
16	8.440	E	3.500	6.125	1.625	2.938	2.625	1.563	6.000	B1	S	11.20
17	8.920	E	3.500	6.125	1.625	2.938	2.625	1.563	6.000	B1	S	13.40
18	9.410	E	3.500	6.250	1.625	2.938	2.625	1.563	6.000	B1	E	14.80
19	9.890	E	3.500	6.250	1.625	2.938	2.625	1.563	6.000	B1	E	16.50
20	10.370	E	3.500	6.250	1.625	2.938	2.625	1.563	6.000	B1	E	19.20
21	10.850	E	3.500	6.250	1.625	2.938	2.625	1.563	6.000	B1	E	19.90
22	11.330	E	3.500	6.250	1.625	2.938	2.625	1.563	6.000	B1	E	21.60
23	11.810	E	3.500	6.250	1.625	2.938	2.625	1.563	6.000	B1	E	23.80
24	12.290	E	3.500	6.250	1.625	2.938	2.625	1.563	6.000	B1	E	25.80
25	12.770	E	3.500	6.250	1.625	2.938	2.625	1.563	6.000	B1	E	28.10
26	13.250	E	3.500	6.250	1.625	2.938	2.625	1.563	6.000	B1	E	29.90
28	14.210	E	3.500	6.250	1.625	2.938	2.625	1.563	6.000	B1	E	34.70
30	15.170	E	3.500	6.250	1.625	2.938	2.625	1.563	6.000	B1	E	39.40
32	16.130	F	4.000	7.000	2.500	4.000	2.625	1.000	6.625	C	E	50.50
35	17.570	F	4.000	7.000	2.500	4.000	3.625	1.000	6.625	C	E	59.50
36	18.050	F	4.000	7.000	2.500	4.000	3.625	1.000	6.625	C	E	63.40
40	19.960	F	4.000	7.000	2.500	4.000	3.625	1.000	6.625	C	E	77.00
42	20.920	F	4.000	7.000	2.500	4.000	3.625	1.000	6.625	C	E	83.00
45	22.350	F	4.000	7.000	2.500	4.000	3.625	1.000	6.625	C	E	84.00
48	23.790	F	4.000	7.000	2.500	4.000	3.625	1.000	6.625	C	E	92.00
54	26.650	F	4.000	8.000	2.500	4.000	3.625	1.000	6.625	C	E	114.00
60	29.520	J	4.500	8.000	3.188	5.000	4.500	1.1875	7.250	C	E	140.00
70	34.300	J	4.500	8.000	3.188	5.000	4.500	1.1875	7.250	C	E	177.00
80	39.080	J	4.500	8.000	3.188	5.000	4.500	1.1875	7.250	C	E	222.00

\* Please reference QD® bushing dimension table on page 171 for specific information on MAX Bore and keyway data.

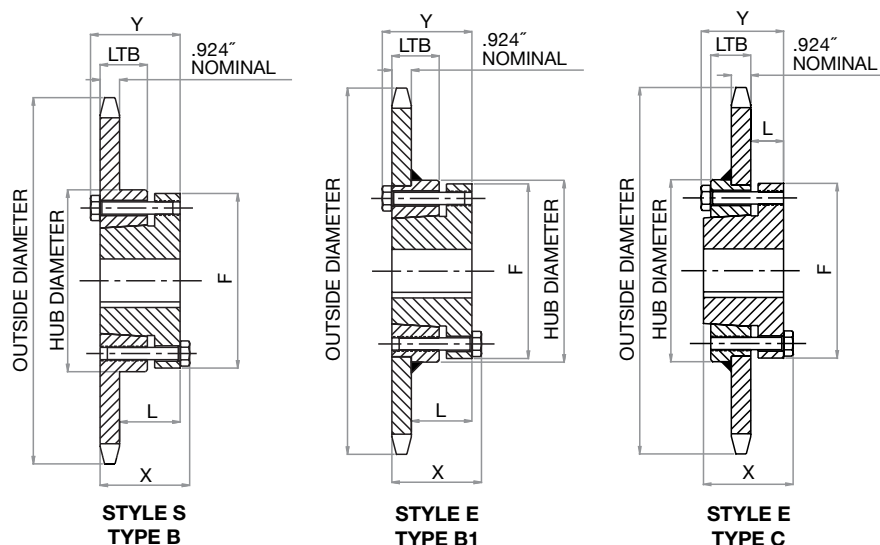

# HOW TO ORDER

TSUBAKI STOCK SPROCKETS



No.  
**140**

**1 3/4" Pitch:  
PLAIN BORE**

Chain Data	
Size	140
Pitch	1 3/4"
Inside Width	1.000"
Roller Diameter	1.000"
Nominal Tooth Width:	0.924"

How to Order Code: Example Model # for 140 Pitch Plain Bore Carbon Steel Sprockets

<b>A</b>	<b>140</b>	<b>C</b>	<b>40</b>
----------	------------	----------	-----------

Altered <sup>¶</sup>	Chain Pitch in Inches	Hub Type	Number of Teeth					
			11	17	23	32	54	
A: Alteration Required	140: 1 3/4" Pitch	A: No Hub Extension	12	18	24	35	60	
			13	19	25	36	70	
			14	20	26	40	80	
			15	21	28	45		
			16	22	30	48		
			11	17	23	32		
		B: Hub Extension One Side	12	18	24			
			13	19	25			
			14	20	26			
			15	21	28			
			16	22	30			
			35	48	80			
		C: Hub Extension Both Sides	36	54				
			40	60				
			45	70				

<sup>¶</sup>Alteration field only to be denoted if a deviation from standard is required. Please reference Alterations in engineering section, page 182.

# No. 140

## PLAIN BORE SPROCKET DIMENSIONS

Tsubaki Stock Sprockets

All dimensions in inches unless noted.

No. 140 Plain Bore Sprocket Dia.				Type "A" Plain Bore		Type "B" & "C" Plain Bore						
No. Teeth	Outside Dia.	Pitch Dia.	Caliper Dia.	Plain Bore	Wt. Lbs.	Plain Bore	MAX Bore *	Hub Dia.	LTB	Hub Type	Hub Style	Wt. Lbs.
11	7.010	6.213	5.148	1.500	5.00	1.500	2.750	4.250	2.250	B	S	11.30
12	7.580	6.762	5.762	1.500	7.80	1.500	3.000	4.500	2.250	B	D	13.20
13	8.150	7.313	6.259	1.500	8.20	1.500	3.563	5.313	2.375	B	D	18.90
14	8.720	7.865	6.865	1.500	10.00	1.500	3.750	5.500	2.375	B	D	20.40
15	9.280	8.418	7.371	1.500	11.00	1.500	4.250	6.250	2.375	B	D	25.10
16	9.850	8.971	7.971	1.500	14.00	1.500	4.250	6.250	2.500	B	D	27.90
17	10.410	9.524	8.483	1.500	16.00	1.500	4.250	6.250	2.500	B	D	29.80
18	10.980	10.078	9.078	1.500	18.00	1.500	4.250	6.250	2.500	B	D	32.00
19	11.540	10.633	9.596	1.500	21.00	1.500	4.250	6.250	2.500	B	D	34.10
20	12.100	11.186	10.186	1.500	23.00	1.500	4.250	6.250	2.500	B	D	36.00
21	12.660	11.743	10.709	1.500	25.00	1.500	4.250	6.250	2.500	B	D	38.70
22	13.220	12.297	11.297	1.500	28.00	1.500	4.250	6.250	2.500	B	D	40.60
23	13.780	12.852	11.822	1.500	30.00	1.500	4.250	6.250	2.500	B	D	42.10
24	14.340	13.407	12.407	1.500	33.00	1.500	4.250	6.250	2.500	B	D	46.20
25	14.900	13.963	12.935	1.500	34.00	1.500	4.250	6.250	2.500	B	D	47.80
26	15.460	14.518	13.518	1.500	39.00	1.500	4.250	6.250	3.000	B	D	57.20
28	16.580	15.629	14.629	1.500	45.00	1.500	4.250	6.250	3.000	B	D	62.20
30	17.700	16.742	15.742	1.500	52.00	1.500	4.250	6.250	3.000	B	D	69.80
32	18.820	17.854	16.854	1.500	60.00	1.500	4.250	6.250	3.000	B	D	76.30
35	20.490	19.523	18.503	1.500	73.00	1.500	5.250	7.000	4.000	C	D	108.00
36	21.050	20.080	19.080	1.500	77.00	1.500	5.250	7.000	4.000	C	D	115.00
40	23.290	22.306	21.306	1.500	93.00	1.500	5.250	7.000	4.000	C	D	121.00
45	26.080	25.088	24.072	1.500	131.00	1.500	5.250	7.000	4.000	C	D	142.00
48	27.750	26.758	25.758	1.500	134.00	1.500	5.250	7.000	4.000	C	D	150.00
54	31.100	30.097	29.097	1.500	173.00	1.500	5.250	7.000	4.000	C	D	177.00
60	34.400	33.437	32.437	1.500	219.00	1.500	5.250	7.000	5.000	C	D	220.00
70	40.020	39.006	38.006	1.500	292.00	1.500	5.375	7.500	5.000	C	D	282.00
80	45.590	44.574	43.574	1.500	402.00	1.500	5.375	7.500	5.000	C	D	331.00

\* Dimensions shown allow for standard keyway with set screw at 90 degrees

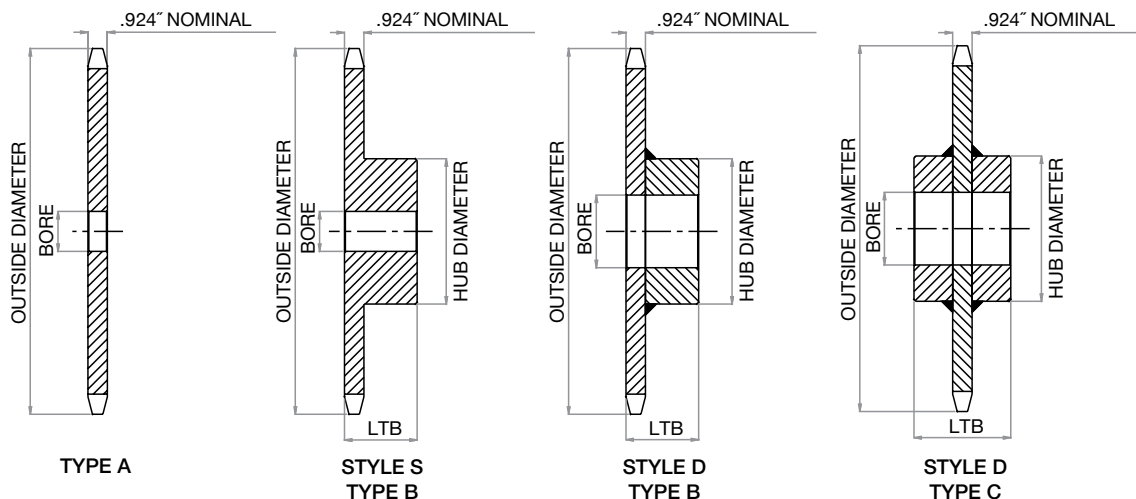

# HOW TO ORDER

TSUBAKI STOCK SPROCKETS



No.  
**140**

**1 3/4" Pitch:  
MULTI-STRAND**

Chain Data	
Size	140
Pitch	1 3/4"
Inside Width	1.000"
Roller Diameter	1.000"
Nominal Tooth Width:	0.894"

How to Order Code: Example Model # for 140 Pitch Multi-Strand Carbon Steel Sprockets

<b>A</b>	<b>D</b>	<b>140</b>	<b>B</b>	<b>25</b>				
Altered <sup>¶</sup>	Multi	Chain Pitch in Inches	Hub Type	Number of Teeth				
A: Alteration Required	D: Double Strand	140: 1 3/4" Pitch	B: Hub Extension One Side	Double Strand				
				13	18	21	25	
				14	17	22	26	
				15	19	23	30	
	16			20	24			
	Triple Strand							
	T: Triple Strand			15				
	18							
	20							

<sup>¶</sup> Alteration field only to be denoted if a deviation from standard is required. Please reference Alterations in engineering section, page 182.

# No. 140

## MULTI-STRAND SPROCKET DIMENSIONS

Tsubaki Stock Sprockets

All dimensions in inches unless noted.

No. 140 Multi-Strand Sprocket Dia.			Dimensional Data: Double Strand Sprockets					
No. Teeth	Outside Diameter	Plain Bore	Hub Diameter	LTB	MAX Bore*	Hub Type	Hub Style	Weight Lbs.
13	8.150	1.625	5.000	3.750	3.313	B	S	29.00
14	8.720	1.625	5.500	3.750	3.750	B	S	34.80
15	9.280	1.625	6.500	3.750	4.500	B	S	42.50
16	9.850	1.625	7.000	4.000	5.250	B	S	48.10
17	10.410	1.625	7.000	4.000	5.250	B	S	57.50
18	10.980	1.750	7.000	4.000	5.250	B	S	65.60
19	11.540	1.750	7.000	4.000	5.250	B	D	72.00
20	12.100	1.750	7.000	4.000	5.250	B	D	76.00
21	12.660	1.750	7.000	4.000	5.250	B	D	82.00
22	13.220	1.750	7.000	4.000	5.250	B	D	94.00
23	13.780	1.750	7.000	4.000	5.250	B	D	100.00
24	14.340	1.750	7.000	4.000	5.250	B	D	104.00
25	14.900	1.750	7.000	4.000	5.250	B	D	120.00
26	15.460	1.750	7.000	4.000	5.250	B	D	128.00
30	17.700	1.750	7.000	4.000	5.250	B	D	163.50

\* Dimensions shown allow for standard keyway with set screw at 90 degrees

All dimensions in inches unless noted.

No. 140 Multi-Strand Sprocket Dia.			Dimensional Data: Triple Strand Sprockets					
No. Teeth	Outside Diameter	Plain Bore	Hub Diameter	LTB	MAX Bore*	Hub Type	Hub Style	Weight Lbs.
15	9.283	1.625	6.500	5.688	4.500	B	S	70.00
18	10.980	1.750	7.000	5.938	5.250	B	S	90.00
20	12.100	1.750	7.000	5.938	5.250	B	S	110.00

\* Dimensions shown allow for standard keyway with set screw at 90 degrees

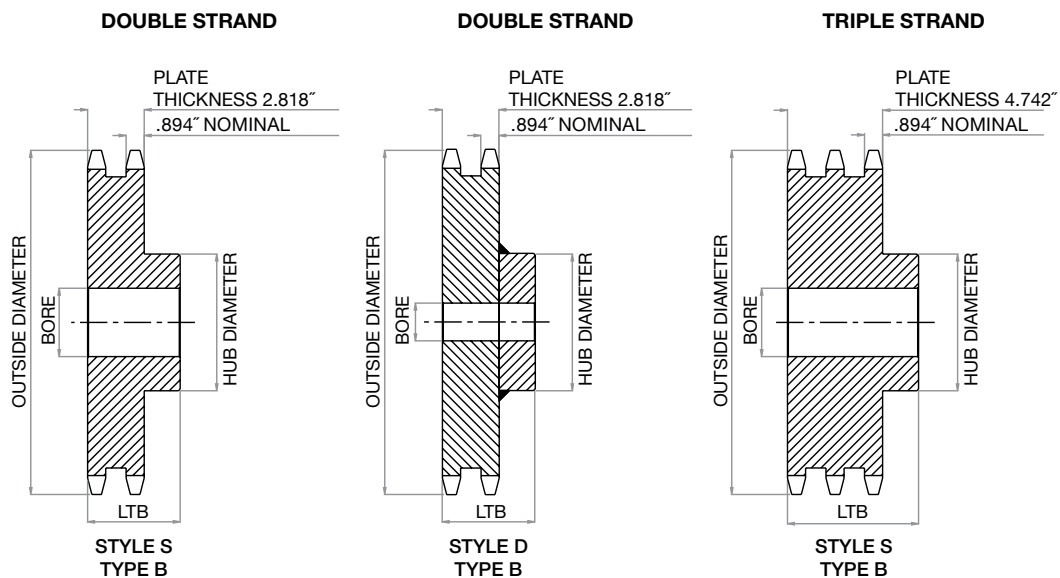



# HOW TO ORDER

TSUBAKI STOCK SPROCKETS



No.  
**140**

**1 3/4" Pitch:  
TAPER-LOCK®**

Chain Data	
Size	140
Pitch	1 3/4"
Inside Width	1.000"
Roller Diameter	1.000"
Nominal Tooth Width:	0.924"

How to Order Code: Example Model # for 140 Pitch TAPER-LOCK® Carbon Steel Sprockets

<b>A</b>	<b>140</b>	<b>B</b>	<b>TL</b>	<b>21</b>					
Altered <sup>¶</sup>	Chain Pitch in Inches	Hub Type	TAPER-LOCK®	Number of Teeth					
A: Alteration Required	140: 1 3/4" Pitch	B: Hub Extension One Side	TAPER-LOCK® hub with set screws	14	18				
				15	19				
				16	21				
		C: Hub Extension Both Side		17	26				
				35	60				
				36	70				
				45					

<sup>¶</sup> Alteration field only to be denoted if a deviation from standard is required. Please reference Alterations in engineering section, page 182.

TAPER-LOCK® bushing is not included with the sprocket. They are to be ordered separately. Please refer to the table below for general guidelines. Specific details are found in the Bushing Section of this catalog beginning on page 164.

TAPER-LOCK® Bushings	
Bushing #	Bore Range
3020	0.875 - 3.250"
3535	1.188 - 3.938"
4040	1.438 - 4.438"

All dimensions in inches unless noted.

No. 140 TAPER-LOCK® Sprockets			Dimensional Data TAPER-LOCK® Sprockets					
No. Teeth	Outside Diameter	Bushing #	Hub Diameter	LTB	MAX Bore *	Hub Type	Hub Style	Weight Lbs.
14	8.720	3020	5.250	2.000	3.250	B	S	10.00
15	9.280	3020	5.250	2.000	3.250	B	S	12.00
16	9.850	3020	5.250	2.000	3.250	B	E	14.00
17	10.410	3020	5.250	2.000	3.250	B	E	16.00
18	10.980	3020	5.250	2.000	3.250	B	E	18.00
19	11.540	3020	5.250	2.000	3.250	B	E	20.00
21	12.660	3020	5.250	2.000	3.250	B	E	24.00
26	15.460	3020	5.250	2.000	3.250	B	E	40.00
35	20.490	3535	6.500	3.500	3.938	C	E	78.00
36	21.050	3535	6.500	3.500	3.938	C	E	83.00
45	26.080	4040	7.750	4.000	4.438	C	E	118.00
60	34.400	4040	7.750	4.000	4.438	C	E	188.00
70	40.020	4040	7.750	4.000	4.438	C	E	241.00

\* Please reference TAPER-LOCK® bushing dimension table on page 165 for specific information on MAX Bore and keyway data.

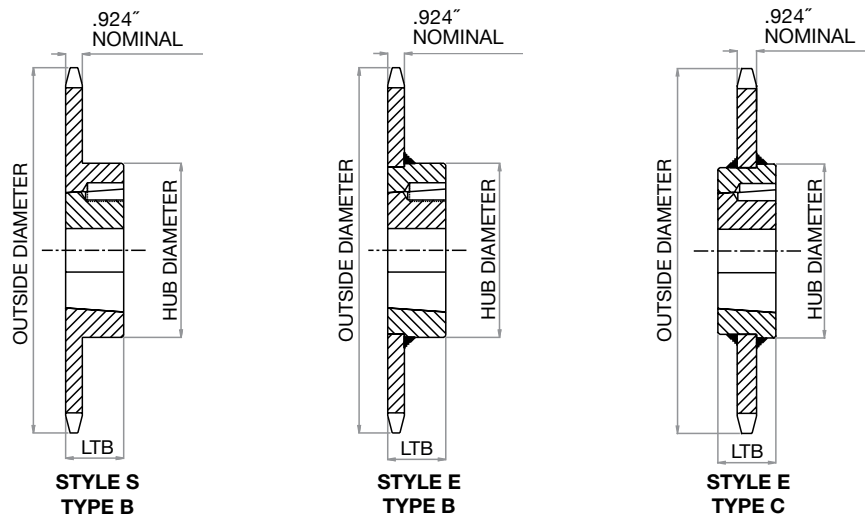

# HOW TO ORDER

TSUBAKI STOCK SPROCKETS



No.  
**140**

**1 3/4" Pitch: QD®**

Chain Data	
Size	140
Pitch	1 3/4"
Inside Width	1.000"
Roller Diameter	1.000"
Nominal Tooth Width:	0.924"

How to Order Code: Example Model # for 140 Pitch QD® Carbon Steel Sprockets

<b>A</b>	<b>140</b>	<b>SF</b>	<b>13</b>
----------	------------	-----------	-----------

Altered <sup>!!</sup>	Chain Pitch in Inches	QD® Hub Type	Number of Teeth				
A: Alteration Required	140: 1 3/4" Pitch	SF: QD® Hub 11 - 13 tooth sprocket	11	13			
			12				
		E: QD® Hub 14 - 22 tooth sprocket	14	16	18	20	22
			15	17	19	21	
		F: QD® Hub 23 - 36 tooth sprocket	23	25	30	36	
			24	26	35		
		J: QD® Hub 40 - 60 tooth sprocket	40	48	60		
			45	54			
		M: QD® Hub 70 & 80 tooth sprocket	70				
			80				

<sup>!!</sup>Alteration field only to be denoted if a deviation from standard is required. Please reference Alterations in engineering section, page 182.

QD® bushing is not included with the sprocket. They are to be ordered separately. Please refer to the table below for general guidelines. Specific details are found in the Bushing Section of this catalog beginning on page 170.

QD® Bushings	
Bushing #	Bore Range
SF	0.500 - 2.938"
E	0.875 - 3.500"
F	1.000 - 4.000"
J	1.500 - 4.500"
M	2.000 - 5.500"

# No. 140

## QD® SPROCKET DIMENSIONS

Tsubaki Stock Sprockets

All dimensions in inches unless noted.

No. 140 QD® Sprockets			Dimensional Data QD® Sprockets									
No. Teeth	Outside Dia.	QD® Bushing #	MAX Bore*	Hub Dia.	LTB	X	Y	L	F	Hub Type	Hub Style	Weight Lbs.
11	7.010	SF	2.938	4.438	1.250	2.250	2.250	1.098	4.625	B	S	5.60
12	7.580	SF	2.938	4.875	1.250	2.250	2.250	1.098	4.625	B	S	7.40
13	8.150	SF	2.938	5.000	1.250	2.250	2.250	1.098	4.625	B	S	8.90
14	8.720	E	3.500	6.125	1.625	2.938	2.625	1.563	6.000	B1	S	11.60
15	9.280	E	3.500	6.125	1.625	2.938	2.625	1.563	6.000	B1	S	14.20
16	9.850	E	3.500	6.250	1.625	2.938	2.625	1.563	6.000	B1	E	15.90
17	10.410	E	3.500	6.250	1.625	2.938	2.625	1.563	6.000	B1	E	18.00
18	10.980	E	3.500	6.250	1.625	2.938	2.625	1.563	6.000	B1	E	19.60
19	11.540	E	3.500	6.250	1.625	2.938	2.625	1.563	6.000	B1	E	22.00
20	12.100	E	3.500	6.250	1.625	2.938	2.625	1.563	6.000	B1	E	24.60
21	12.660	E	3.500	6.250	1.625	2.938	2.625	1.563	6.000	B1	E	27.60
22	13.220	E	3.500	6.250	1.625	2.938	2.625	1.563	6.000	B1	E	29.50
23	13.780	F	4.000	7.000	2.500	4.000	3.625	2.563	6.625	B1	E	36.40
24	14.340	F	4.000	7.000	2.500	4.000	3.625	2.563	6.625	B1	E	40.10
25	14.900	F	4.000	7.000	2.500	4.000	3.625	2.563	6.625	B1	E	42.30
26	15.460	F	4.000	7.000	2.500	4.000	3.625	2.563	6.625	B1	E	46.50
30	17.700	F	4.000	7.000	2.500	4.000	3.625	2.563	6.625	B1	E	60.40
35	20.490	F	4.000	7.000	2.500	4.000	3.625	1.000	6.625	C	E	78.00
36	21.050	F	4.000	7.000	2.500	4.000	3.625	1.000	6.625	C	E	84.00
40	23.290	J	4.500	8.000	3.188	5.000	4.500	1.188	7.250	C	E	98.00
45	26.080	J	4.500	8.000	3.188	5.000	4.500	1.188	7.250	C	E	120.00
48	27.750	J	4.500	8.000	3.188	5.000	4.500	1.188	7.250	C	E	129.00
54	31.100	J	4.500	8.000	3.188	5.000	4.500	1.188	7.250	C	E	149.00
60	34.440	J	4.500	8.000	3.188	5.000	4.500	1.188	7.250	C	E	185.00
70	40.020	M	5.500	10.000	5.188	6.750	6.750	2.906	9.000	C1	E	264.00
80	45.590	M	5.500	10.000	5.188	6.750	6.750	2.906	9.000	C1	E	348.00

\* Please reference QD® bushing dimension table on page 171 for specific information on MAX Bore and keyway data.

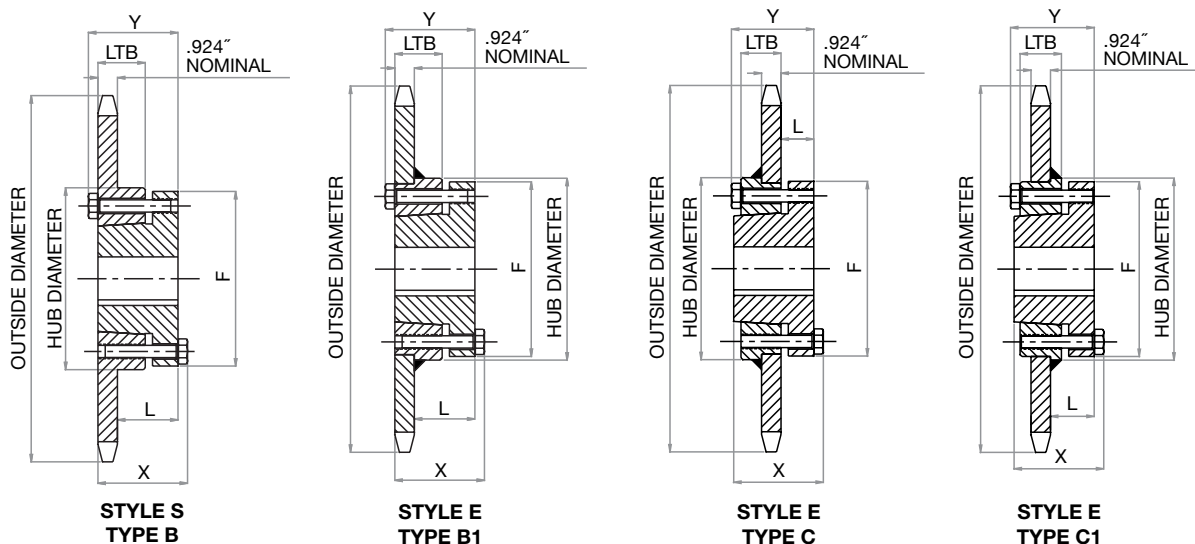

# HOW TO ORDER

TSUBAKI STOCK SPROCKETS



No.  
**160**

2" Pitch:  
**PLAIN BORE**

Chain Data	
Size	160
Pitch	2"
Inside Width	1.250"
Roller Diameter	1.125"
Nominal Tooth Width:	1.156"

How to Order Code: Example Model # for 160 Pitch Plain Bore Carbon Steel Sprockets

<b>A</b>	<b>160</b>	<b>A</b>	<b>25</b>
----------	------------	----------	-----------

Altered <sup>1</sup>	Chain Pitch in Inches	Hub Type	Number of Teeth					
			8	14	20	26	40	
A: Alteration Required	160: 2" Pitch	A: No Hub Extension	9	15	21	27	45	
			10	16	22	28	48	
			11	17	23	30	54	
			12	18	24	35	60	
			13	19	25	36		
		B: Hub Extension One Side	8	14	20	26		
			9	15	21	27		
			10	16	22	28		
			11	17	23	30		
			12	18	24			
		C: Hub Extension Both Sides	13	19	25			
			35	45	60			
			36	48				
				40	54			

<sup>1</sup>Alteration field only to be denoted if a deviation from standard is required. Please reference Alterations in engineering section, page 182.

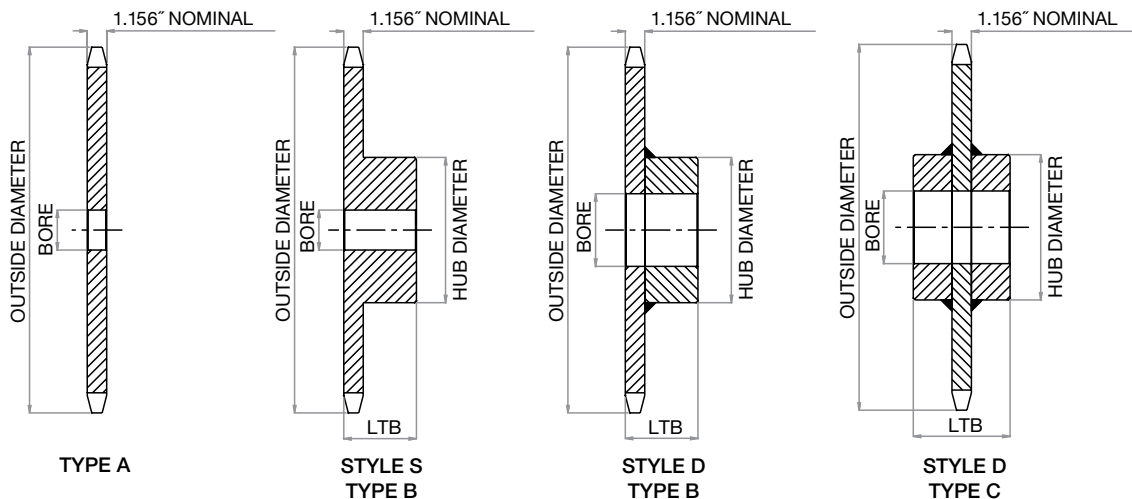

# No. 160

## PLAIN BORE SPROCKET DIMENSIONS

Tsubaki Stock Sprockets

All dimensions in inches unless noted.

No. 160 Plain Bore Sprocket Dia.				Type "A" Plain Bore		Type "B" & "C" Plain Bore						
No. Teeth	Outside Dia.	Pitch Dia.	Caliper Dia.	Plain Bore	Wt. Lbs.	Plain Bore	MAX Bore *	Hub Dia.	LTB	Hub Type	Hub Style	Wt. Lbs.
8	6.030	5.226	4.101	1.500	5.00	1.500	1.875	3.250	2.250	B	S	8.00
9	6.700	5.848	4.635	1.500	7.00	1.500	2.125	3.625	2.250	B	S	10.00
10	7.380	6.472	5.347	1.500	8.00	1.500	2.750	4.125	2.250	B	S	12.00
11	8.010	7.100	5.902	1.500	10.00	1.500	3.250	4.750	2.500	B	S	17.00
12	8.660	7.728	6.603	1.500	12.00	1.500	3.750	5.500	2.500	B	S	21.00
13	9.310	8.358	7.171	1.500	16.00	1.500	4.000	6.000	2.750	B	S	28.00
14	9.960	8.988	7.863	1.500	17.00	1.500	4.500	6.500	2.750	B	D	32.00
15	10.610	9.620	8.442	1.500	21.00	1.500	5.250	7.000	2.750	B	D	37.00
16	11.260	10.252	9.127	1.500	24.00	1.500	5.250	7.000	2.750	B	D	41.00
17	11.900	10.844	9.713	1.500	27.00	1.500	5.250	7.000	2.750	B	D	45.00
18	12.540	11.518	10.393	1.500	30.00	1.500	5.250	7.000	2.750	B	D	48.00
19	13.190	12.152	10.985	1.500	34.00	1.500	5.250	7.000	2.750	B	D	52.00
20	13.830	12.784	11.659	1.500	38.00	1.500	5.250	7.000	2.750	B	D	56.00
21	14.470	13.420	12.256	1.500	42.00	1.500	5.250	7.000	2.750	B	D	59.00
22	15.110	14.054	12.929	1.500	46.00	1.500	5.250	7.000	2.750	B	D	65.00
23	15.750	14.688	13.529	1.500	50.00	1.500	5.250	7.000	2.750	B	D	68.00
24	16.390	15.322	14.197	1.500	56.00	1.500	5.250	7.000	3.000	B	D	77.00
25	17.030	15.958	14.801	1.500	61.00	1.500	5.250	7.000	3.000	B	D	81.00
26	17.670	16.592	15.467	1.500	65.00	1.500	5.250	7.000	3.000	B	D	86.00
27	18.310	17.228	16.073	1.500	71.00	1.500	5.250	7.000	3.000	B	D	91.00
28	18.950	17.862	16.737	1.500	77.00	1.500	5.250	7.000	3.000	B	D	98.00
30	20.230	19.134	18.009	1.500	90.00	1.500	5.250	7.000	3.000	B	D	108.00
35	23.420	22.312	21.164	1.500	121.00	1.500	5.500	8.000	4.500	C	D	154.00
36	24.060	22.948	21.823	1.500	134.00	1.500	5.500	8.000	4.500	C	D	170.00
40	26.610	25.492	24.367	1.500	138.00	1.500	5.500	8.000	4.500	C	D	196.00
45	29.800	28.672	27.529	1.500	204.00	1.500	5.500	8.000	5.000	C	D	234.00
48	31.714	30.580	29.455	1.500	233.00	1.500	5.500	8.000	5.000	C	D	250.00
54	35.540	34.396	33.271	1.500	294.00	1.500	5.500	8.000	5.000	C	D	345.00
60	39.360	38.214	37.089	1.500	360.00	1.500	5.500	8.000	5.000	C	D	415.00

\* Dimensions shown allow for standard keyway with set screw at 90 degrees

# HOW TO ORDER

TSUBAKI STOCK SPROCKETS



No.  
**160**      2" Pitch:  
**MULTI-STRAND**

Chain Data	
Size	160
Pitch	2"
Inside Width	1.250"
Roller Diameter	1.125"
Nominal Tooth Width:	1.119"

How to Order Code: Example Model # for 160 Pitch Multi-Strand Carbon Steel Sprockets

<b>A</b>	<b>D</b>	<b>160</b>	<b>B</b>	<b>21</b>					
Altered <sup>#</sup>	Multi	Chain Pitch in Inches	Hub Type	Number of Teeth					
A: Alteration Required	D: Double Strand	160: 2" Pitch	B: Hub Extension One Side	13	17	21	25		
				14	18	22	26		
				15	19	23	30		
				16	20	24			

<sup>#</sup> Alteration field only to be denoted if a deviation from standard is required. Please reference Alterations in engineering section, page 182.

All dimensions in inches unless noted.

No. 160 Multi-Strand Sprocket Dia.			Dimensional Data: Double Strand Sprockets					
No. Teeth	Outside Diameter	Plain Bore	Hub Diameter	LTB	MAX Bore*	Hub Type	Hub Style	Weight Lbs.
13	9.310	2.000	6.000	4.750	4.000	B	D	48.00
14	9.960	2.000	6.750	4.750	4.750	B	D	58.00
15	10.610	2.000	7.000	4.750	5.250	B	D	68.00
16	11.260	2.000	7.000	4.750	5.250	B	D	75.00
17	11.900	2.000	7.000	4.750	5.250	B	D	91.00
18	12.540	2.000	7.000	4.750	5.250	B	D	96.00
19	13.190	2.000	7.000	4.750	5.250	B	D	107.00
20	13.830	2.000	7.000	4.750	5.250	B	D	119.00
21	14.470	2.000	7.500	4.750	5.375	B	D	130.00
22	15.110	2.000	7.500	4.750	5.375	B	D	141.00
23	15.750	2.000	7.500	4.750	5.375	B	D	157.00
24	16.390	2.000	7.500	4.750	5.375	B	D	171.00
25	17.030	2.000	7.500	4.750	5.375	B	D	187.00
26	17.670	2.000	7.500	4.750	5.375	B	D	201.00
30	20.230	2.000	7.500	4.750	5.375	B	D	260.00

\* Dimensions shown allow for standard keyway with set screw at 90 degrees

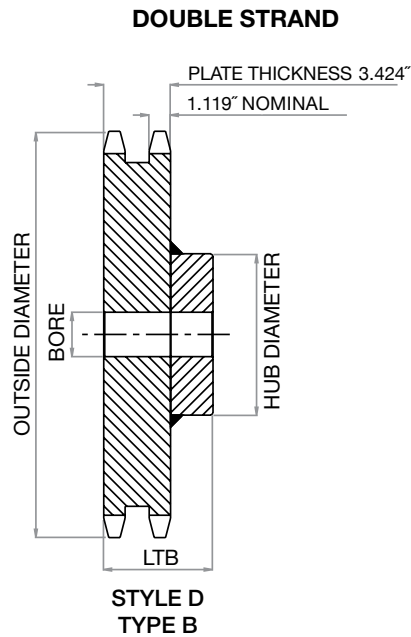



# HOW TO ORDER

TSUBAKI STOCK SPROCKETS



No.  
**160**      2" Pitch: QD®

Chain Data	
Size	160
Pitch	2"
Inside Width	1.250"
Roller Diameter	1.125"
Nominal Tooth Width:	1.156"

How to Order Code: Example Model # for 160 Pitch QD® Carbon Steel Sprockets

<b>A</b>	<b>160</b>	<b>F</b>	<b>17</b>				
Altered <sup>!!</sup>	Chain Pitch in Inches	QD® Hub Type	Number of Teeth				
A: Alteration Required	160: 2" Pitch	E: QD® Hub 13 - 14 tooth sprocket	13				
			14				
		F: QD® Hub 15 - 25 tooth sprocket	15	18	21	24	
			16	19	22	25	
			17	20	23		
		J: QD® Hub 26 - 35 tooth sprocket	26	35			
			28				
			30				
		M: QD® Hub 40 - 60 tooth sprocket	40	60			
			45				
			54				

<sup>!!</sup>Alteration field only to be denoted if a deviation from standard is required. Please reference Alterations in engineering section, page 182.

QD® bushing is not included with the sprocket. They are to be ordered separately. Please refer to the table below for general guidelines. Specific details are found in the Bushing Section of this catalog beginning on page 170.

QD® Bushings	
Bushing #	Bore Range
E	0.875 - 3.500"
F	1.000 - 4.000"
J	1.500 - 4.500"
M	2.000 - 5.500"

# No. 160

## QD® SPROCKET DIMENSIONS

Tsubaki Stock Sprockets

All dimensions in inches unless noted.

No. 160 QD® Sprockets			Dimensional Data QD® Sprockets									
No. Teeth	Outside Dia.	QD® Bushing #	MAX Bore*	Hub Dia.	LTB	X	Y	L	F	Hub Type	Hub Style	Weight Lbs.
13	9.310	E	3.500	6.000	1.625	2.625	2.937	1.313	6.000	B1	S	14.00
14	9.960	E	3.500	6.000	1.625	2.625	2.937	1.313	6.000	B1	S	15.00
15	10.610	F	4.000	6.625	2.500	3.625	4.000	2.313	6.625	B1	E	24.00
16	11.260	F	4.000	6.625	2.500	3.625	4.000	2.313	6.625	B1	E	27.00
17	11.900	F	4.000	6.625	2.500	3.625	4.000	2.313	6.625	B1	E	31.00
18	12.540	F	4.000	6.625	2.500	3.625	4.000	2.313	6.625	B1	E	35.00
19	13.190	F	4.000	6.625	2.500	3.625	4.000	2.313	6.625	B1	E	38.00
20	13.830	F	4.000	6.625	2.500	3.625	4.000	2.313	6.625	B1	E	42.00
21	14.740	F	4.000	6.625	2.500	3.625	4.000	2.313	6.625	B1	E	45.00
22	15.110	F	4.000	6.625	2.500	3.625	4.000	2.313	6.625	B1	E	51.00
23	15.750	F	4.000	6.625	2.500	3.625	4.000	2.313	6.625	B1	E	55.00
24	16.390	F	4.000	6.625	2.500	3.625	4.000	2.313	6.625	B1	E	59.00
25	17.030	F	4.000	6.625	2.500	3.625	4.000	2.313	6.625	B1	E	64.00
26	17.670	J	4.500	7.250	3.188	4.500	5.000	1.188	7.250	C	E	74.00
28	18.950	J	4.500	7.250	3.188	4.500	5.000	1.188	7.250	C	E	84.00
30	20.230	J	4.500	7.250	3.188	4.500	5.000	1.188	7.250	C	E	96.00
35	23.420	J	4.500	7.250	3.188	4.500	5.000	1.188	7.250	C	E	116.00
40	26.610	M	5.500	9.000	5.188	6.750	6.750	1.594	9.000	C1	E	174.00
45	29.800	M	5.500	9.000	5.188	6.750	6.750	1.594	9.000	C1	E	208.00
54	35.540	M	5.500	9.000	5.188	6.750	6.750	1.594	9.000	C1	E	262.00
60	39.360	M	5.500	9.000	5.188	6.750	6.750	1.594	9.000	C1	E	310.00

\* Please reference QD® bushing dimension table on page 171 for specific information on MAX Bore and keyway data.

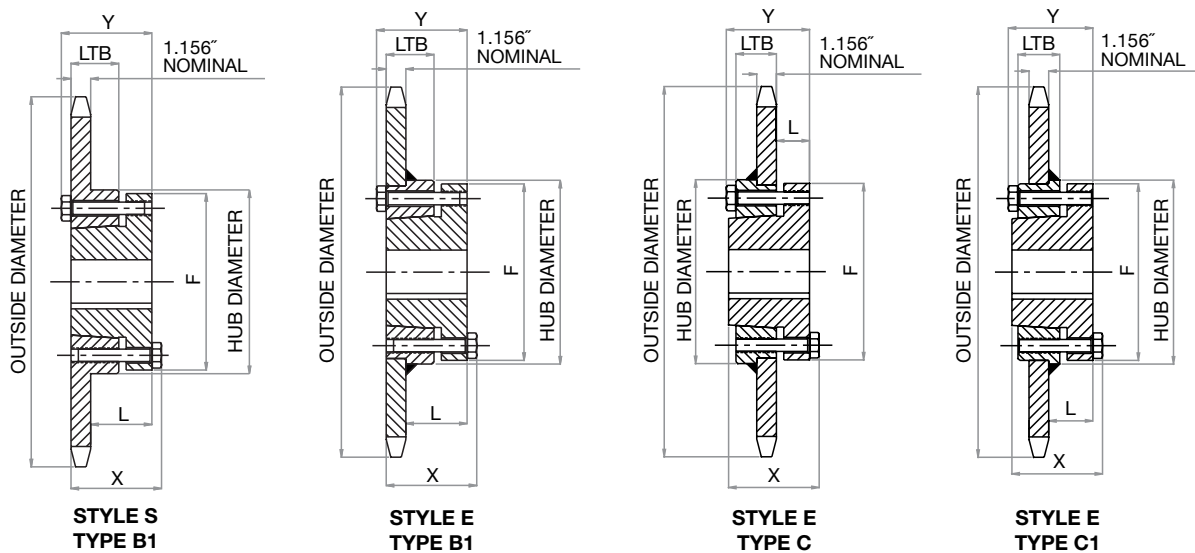

# HOW TO ORDER

TSUBAKI STOCK SPROCKETS



No.  
**180**

**2 1/4" Pitch:  
PLAIN BORE**

Chain Data	
Size	180
Pitch	2 1/4"
Inside Width	1.406"
Roller Diameter	1.406"
Nominal Tooth Width:	1.301"

How to Order Code: Example Model # for 180 Pitch Plain Bore Carbon Steel Sprockets

<b>A</b>	<b>180</b>	<b>B</b>	<b>25</b>				
Altered <sup>1</sup>	Chain Pitch in Inches	Hub Type	Number of Teeth				
A: Alteration Required	180: 2 1/4" Pitch	A: No Hub Extension	11	15	19	23	
			12	16	20	24	
			13	17	21	25	
			14	18	22	28	
		B: Hub Extension One Side	11	15	19	23	
			12	16	20	24	
			13	17	21	25	
			14	18	22	28	

<sup>1</sup>Alteration field only to be denoted if a deviation from standard is required. Please reference Alterations in engineering section, page 182.

All dimensions in inches unless noted.

No. 180 Plain Bore Sprocket Dia.				Type "A" Plain Bore		Type "B" Plain Bore						
No. Teeth	Outside Dia.	Pitch Dia.	Caliper Dia.	Plain Bore	Wt. Lbs.	Plain Bore	MAX Bore *	Hub Dia.	LTB	Hub Type	Hub Style	Wt. Lbs.
11	9.010	7.986	6.499	1.500	14.00	1.500	3.625	5.500	3.000	B	S	29.00
12	9.750	8.693	7.287	1.500	16.00	1.500	4.000	6.000	3.000	B	D	32.00
13	10.480	9.402	7.927	1.500	20.00	1.500	4.625	6.750	3.125	B	D	40.00
14	11.210	10.111	8.705	1.500	24.00	1.500	5.250	7.000	3.125	B	D	44.00
15	11.930	10.822	9.357	1.500	28.00	1.500	5.250	7.000	3.125	B	D	48.00
16	12.660	11.533	10.127	1.500	32.00	1.500	5.250	7.000	3.125	B	D	52.00
17	13.390	12.245	10.787	1.500	37.00	1.500	5.250	7.000	3.125	B	D	58.00
18	14.110	12.957	11.551	1.500	43.00	1.500	5.250	7.000	3.125	B	D	63.00
19	14.830	13.670	12.217	1.500	47.00	1.500	5.375	7.500	3.375	B	D	74.00
20	15.560	14.383	12.977	1.500	53.00	1.500	5.375	7.500	3.375	B	D	81.00
21	16.280	15.096	13.648	1.500	57.00	1.500	5.375	7.500	3.375	B	D	83.00
22	17.000	15.810	14.404	1.500	62.00	1.500	5.375	7.500	3.375	B	D	92.00
23	17.720	16.524	15.079	1.500	69.00	1.500	5.375	7.500	3.375	B	D	99.00
24	18.440	17.238	15.832	1.500	77.00	1.500	5.375	7.500	3.375	B	D	105.00
25	19.160	17.952	16.511	1.500	84.00	1.500	5.375	7.500	3.375	B	D	113.00
28	21.320	20.096	18.690	1.500	104.00	1.500	5.500	8.000	3.500	B	D	135.00

\* Dimensions shown allow for standard keyway with set screw at 90 degrees

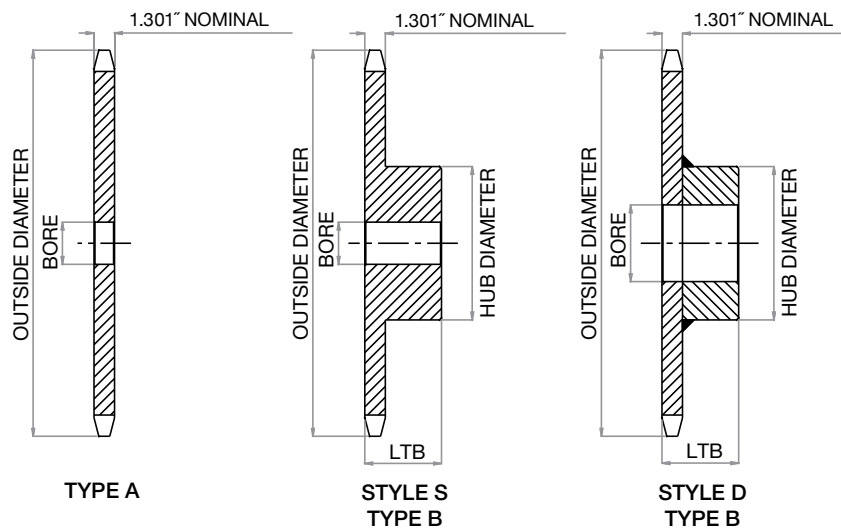

# HOW TO ORDER

TSUBAKI STOCK SPROCKETS



No. **200**      **2½" Pitch:**  
**PLAIN BORE**

Chain Data	
Size	200
Pitch	2½"
Inside Width	1.500"
Roller Diameter	1.562"
Nominal Tooth Width:	1.389"

How to Order Code: Example Model # for 200 Pitch Plain Bore Carbon Steel Sprockets

<b>A</b>	<b>200</b>	<b>B</b>	<b>25</b>
----------	------------	----------	-----------

Altered <sup>1</sup>	Chain Pitch in Inches	Hub Type	Number of Teeth				
			10	14	18	25	45
A: Alteration Required	200: 2½" Pitch	A: No Hub Extension	10	14	18	25	45
			11	15	19	30	54
			12	16	20	35	60
			13	17	21	40	
		B: Hub Extension One Side	10	14	18	25	
			11	15	19		
			12	16	20		
			13	17	21		
		C: Hub Extension Both Sides	30	45			
			35	54			
			40	60			

<sup>1</sup>Alteration field only to be denoted if a deviation from standard is required. Please reference Alterations in engineering section, page 182.

# No. 200

## PLAIN BORE SPROCKET DIMENSIONS

Tsubaki Stock Sprockets

All dimensions in inches unless noted.

No. 200 Plain Bore Sprocket Dia.				Type "A" Plain Bore		Type "B" & "C" Plain Bore						
No. Teeth	Outside Dia.	Pitch Dia.	Caliper Dia.	Plain Bore	Wt. Lbs.	Plain Bore	MAX Bore *	Hub Dia.	LTB	Hub Type	Hub Style	Wt. Lbs.
10	9.200	8.090	6.528	1.500	16.00	1.500	3.750	5.500	3.000	B	S	26.00
11	10.020	8.872	7.219	1.500	20.00	1.500	4.000	6.000	3.000	B	D	33.00
12	10.830	9.660	8.098	1.500	24.00	1.500	4.500	6.500	3.000	B	D	37.00
13	11.640	10.447	8.808	1.500	30.00	1.500	5.250	7.000	3.000	B	D	46.00
14	12.460	11.235	9.673	1.500	32.00	1.500	5.375	7.500	3.500	B	D	59.00
15	13.260	12.025	10.397	1.500	40.00	1.500	5.375	7.500	3.500	B	D	64.00
16	14.070	12.815	11.253	1.500	46.00	1.500	5.375	7.500	3.500	B	D	72.00
17	14.870	13.605	11.985	1.500	51.00	1.500	5.375	7.500	3.500	B	D	76.00
18	15.680	14.397	12.835	1.500	57.00	1.500	5.375	7.500	3.500	B	D	84.00
19	16.480	15.190	13.576	1.500	65.00	1.500	5.375	7.500	3.500	B	D	91.00
20	17.290	15.982	14.420	1.500	72.00	1.500	5.375	7.500	3.500	B	D	98.00
21	18.090	16.775	15.166	1.500	82.00	1.500	5.375	7.500	3.500	B	D	106.00
25	20.490	19.152	17.590	1.500	113.00	1.500	5.750	8.500	4.000	B	D	153.00
30	25.290	23.917	22.355	1.500	167.00	1.500	5.750	8.500	4.500	C	D	212.00
35	29.280	27.890	26.300	1.500	227.00	1.500	5.750	8.500	4.500	C	D	254.00
40	33.270	31.865	30.303	1.500	301.00	1.500	6.000	9.000	5.000	C	D	320.00
45	37.250	35.840	34.256	1.500	356.00	1.500	6.000	9.000	5.000	C	D	390.00
54	44.420	42.995	41.433	1.500	479.00	1.500	6.500	9.500	5.500	C	D	555.00
60	49.200	47.767	46.205	1.500	654.00	1.500	6.500	9.500	5.500	C	D	692.00

\* Dimensions shown allow for standard keyway with set screw at 90 degrees

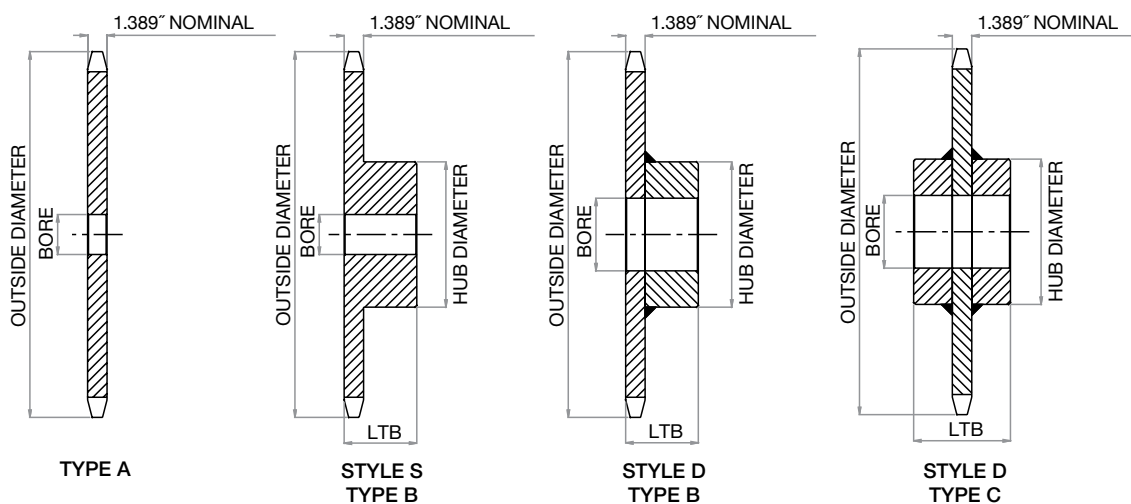

# HOW TO ORDER

TSUBAKI STOCK SPROCKETS



No.  
**240**      3" Pitch:  
**PLAIN BORE**

Chain Data	
Size	240
Pitch	3"
Inside Width	1.875"
Roller Diameter	1.875"
Nominal Tooth Width:	1.738"

How to Order Code: Example Model # for 240 Pitch Plain Bore Carbon Steel Sprockets

<b>A</b>	<b>240</b>	<b>B</b>	<b>21</b>
----------	------------	----------	-----------

Altered <sup>1</sup>	Chain Pitch in Inches	Hub Type	Number of Teeth				
			10	14	18	25	45
A: Alteration Required	240: 3" Pitch	A: No Hub Extension	11	15	19	30	54
			12	16	20	35	60
			13	17	21	40	
			10	14	18	25	
		B: Hub Extension One Side	11	15	19		
			12	16	20		
			13	17	21		
			30	45			
		C: Hub Extension Both Sides	35	54			
			40	60			

<sup>1</sup>Alteration field only to be denoted if a deviation from standard is required. Please reference Alterations in engineering section, page 182.

All dimensions in inches unless noted.

No. 240 Plain Bore Sprocket Dia.				Type "A" Plain Bore		Type "B" & "C" Plain Bore						
No. Teeth	Outside Dia.	Pitch Dia.	Caliper Dia.	Plain Bore	Wt. Lbs.	Plain Bore	MAX Bore *	Hub Dia.	LTB	Hub Type	Hub Style	Wt. Lbs.
10	11.030	9.708	7.833	1.500	30.00	1.500	4.500	6.500	3.375	B	S	49.00
11	12.020	10.648	8.665	1.500	37.00	1.500	4.750	7.000	3.875	B	D	66.00
12	13.000	11.591	9.716	1.500	45.00	1.500	5.375	7.500	3.875	B	D	72.00
13	13.970	12.536	10.569	1.500	54.00	1.500	5.375	7.500	3.875	B	D	81.00
14	14.940	13.482	11.607	1.500	62.00	1.500	5.375	7.500	3.875	B	D	88.00
15	15.910	14.429	12.475	1.500	68.00	1.500	5.375	7.500	3.875	B	D	98.00
16	16.880	15.377	13.502	1.500	82.00	1.500	5.500	8.000	4.125	B	D	120.00
17	17.850	16.327	14.382	1.500	93.00	1.500	5.500	8.000	4.125	B	D	137.00
18	18.810	17.276	15.401	1.500	108.00	1.500	5.500	8.000	4.125	B	D	142.00
19	19.780	18.227	16.289	1.500	120.00	1.500	5.500	8.000	4.125	B	D	154.00
20	20.740	19.177	17.302	1.500	128.00	1.500	5.500	8.000	4.125	B	D	169.00
21	21.710	20.129	18.197	1.500	148.00	1.500	5.500	8.000	4.125	B	D	186.00
25	25.550	23.936	22.014	1.500	208.00	1.500	5.500	8.000	4.125	B	D	254.00
30	30.340	28.700	26.825	1.500	310.00	1.500	6.000	9.000	6.250	C	D	398.00
35	35.130	33.467	31.559	1.500	416.00	1.500	6.000	9.000	6.250	C	D	527.00
40	39.920	38.237	36.362	1.500	548.00	1.500	7.000	10.000	6.750	C	D	672.00
45	44.700	43.007	41.106	1.500	702.00	1.500	7.000	10.000	6.750	C	D	850.00
54	53.310	51.595	49.720	1.500	1022.00	1.500	7.000	10.000	6.750	C	D	1148.00
60	59.040	57.322	55.447	1.500	1268.00	1.500	7.000	10.000	6.750	C	D	1419.00

\* Dimensions shown allow for standard keyway with set screw at 90 degrees

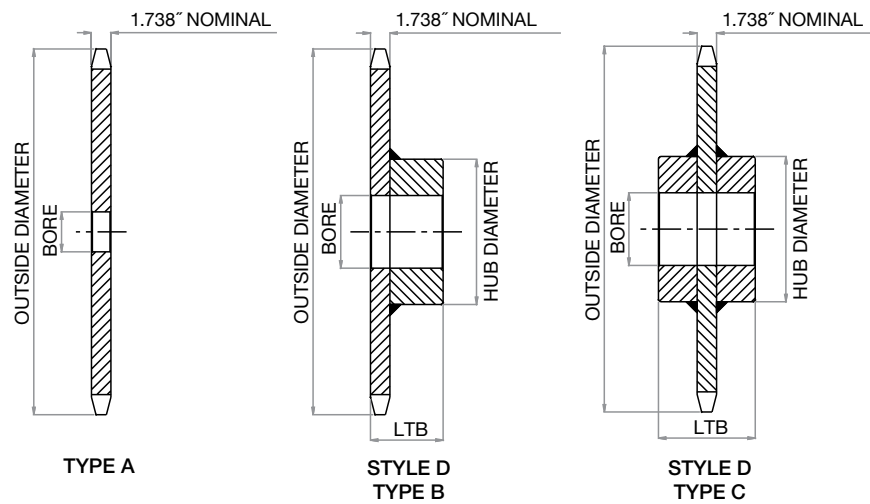



# HOW TO ORDER

TSUBAKI STOCK SPROCKETS



No.  
**2040**

1" Pitch:  
**DOUBLEPITCH**

Chain Data	
Size	2040
Pitch	1"
Inside Width	5/16"
Roller Diameter	0.313"
Nominal Tooth Width:	0.284"

How to Order Code: Example Model # for 2040 Pitch Plain Bore Carbon Steel Sprockets

Conveyor or Drive Series standard roller Double Pitch sprockets

For use with Tsubaki C2040/A2040 Chain - 1" Pitch

<b>A</b>	<b>2040</b>	<b>B</b>	<b>21</b>
----------	-------------	----------	-----------

Altered <sup>1</sup>	Chain Pitch in Inches	Hub Type	Number of Teeth					
			23	25	28			
A: Alteration Required	2040: 1" Pitch	A: No Hub Extension	24	26	30			
				B: Hub Extension One Side	11	17	23	
					12	18	24	
					13	19	25	
					14	20	26	
					15	21	28	
					16	22	30	

<sup>1</sup>Alteration field only to be denoted if a deviation from standard is required. Please reference Alterations in engineering section, page 182.

# No. 2040

## PLAIN BORE SPROCKET DIMENSIONS

Tsubaki Stock Sprockets

All dimensions in inches unless noted.

No. 2040 Plain Bore Sprocket Dia.				Type "A" Plain Bore		Type "B" Plain Bore						
No. Teeth	Outside Dia.	Pitch Dia.	Caliper Dia.	Plain Bore	Wt. Lbs.	Plain Bore	MAX Bore *	Hub Dia.	LTB	Hub Type	Hub Style	Wt. Lbs.
11	2.000	1.852	1.537	N/A	N/A	0.500	0.813	1.375 "	0.875	B	S	0.34
12	2.170	2.000	1.688	N/A	N/A	0.500	0.813	1.563 "	0.875	B	S	0.44
13	2.330	2.152	1.824	N/A	N/A	0.500	0.656	1.563 "	0.875	B	S	0.48
14	2.490	2.305	1.993	N/A	N/A	0.500	1.031	1.688 "	0.875	B	S	0.60
15	2.650	2.458	2.133	N/A	N/A	0.625	1.219	1.781	0.875	B	S	0.66
16	2.810	2.613	2.301	N/A	N/A	0.625	1.281	1.875	0.875	B	S	0.76
17	2.980	2.768	2.444	N/A	N/A	0.625	1.313	2.047	1.000	B	S	1.00
18	3.140	2.924	2.612	N/A	N/A	0.625	1.469	2.219	1.000	B	S	1.16
19	3.300	3.080	2.757	N/A	N/A	0.625	1.625	2.375	1.000	B	S	1.36
20	3.460	3.236	2.924	N/A	N/A	0.625	1.750	2.547	1.000	B	S	1.54
21	3.620	3.392	3.070	N/A	N/A	0.625	1.781	2.703	1.000	B	S	1.74
22	3.780	3.549	3.237	N/A	N/A	0.625	1.875	2.875	1.000	B	S	1.92
23	3.940	3.706	3.386	0.625	0.77	0.625	2.000	3.000	1.000	B	D	2.16
24	4.100	3.864	3.552	0.625	0.84	0.625	2.250	3.250	1.000	B	D	2.44
25	4.260	4.021	3.701	0.625	0.91	0.625	2.250	3.250	1.000	B	D	2.48
26	4.420	4.179	3.867	0.625	1.00	0.625	2.250	3.250	1.000	B	D	2.60
28	4.740	4.494	4.182	0.625	1.10	0.625	2.250	3.250	1.000	B	D	2.74
30	5.060	4.810	4.498	0.625	1.30	0.625	2.250	3.250	1.000	B	D	2.92

\* Dimensions shown allow for standard keyway with set screw at 90 degrees

" Has recessed groove in hub for chain clearance

N/A = Non applicable/Not Available as standard

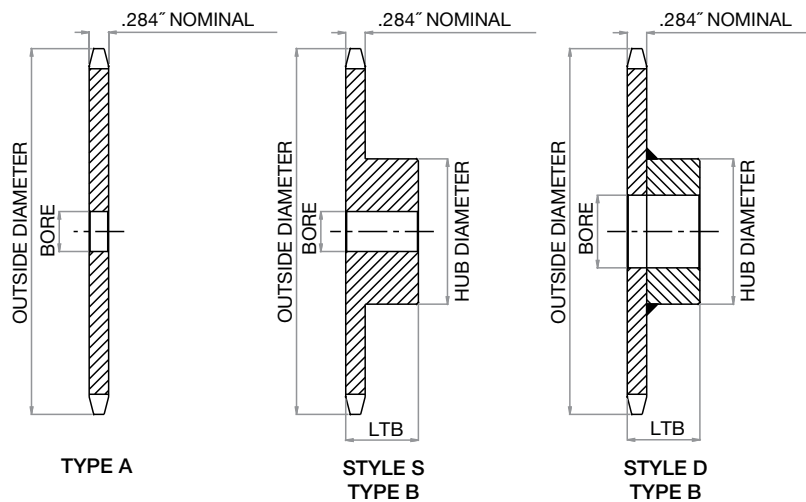

# HOW TO ORDER

TSUBAKI STOCK SPROCKETS



No.  
**2042**      1" Pitch:  
**DOUBLEPITCH**

Chain Data	
Size	2042
Pitch	1"
Inside Width	5/16"
Roller Diameter	0.625"
Nominal Tooth Width:	0.284"

How to Order Code: Example Model # for 2042 Pitch Plain Bore Carbon Steel Sprockets  
 Conveyor Series large roller Double Pitch sprockets  
 For use with Tsubaki C2042 Chain - 1" Pitch

<b>A</b>	<b>2042</b>	<b>B</b>	<b>26</b>				
Altered <sup>11</sup>	Chain Pitch in Inches	Hub Type	Number of Teeth				
A: Alteration Required	2042: 1" Pitch	A: No Hub Extension	16	21	26		
			17	22	28		
			18	23	30		
			19	24			
			20	25			
		B: Hub Extension One Side	8	14	20	26	
			9	15	21	28	
			10	16	22	30	
			11	17	23		
			12	18	24		
			13	19	25		

<sup>11</sup>Alteration field only to be denoted if a deviation from standard is required. Please reference Alterations in engineering section, page 182.

# No. 2042

## PLAIN BORE SPROCKET DIMENSIONS

Tsubaki Stock Sprockets

All dimensions in inches unless noted.

No. 2042 Plain Bore Sprocket Dia.				Type "A" Plain Bore		Type "B" Plain Bore						
No. Teeth	Outside Dia.	Pitch Dia.	Caliper Dia.	Plain Bore	Wt. Lbs.	Plain Bore	MAX Bore *	Hub Dia.	LTB	Hub Type	Hub Style	Wt. Lbs.
8	3.010	2.613	1.988	N/A	N/A	0.625	1.281	1.875	0.875	B	S	0.72
9	3.350	2.924	2.255	N/A	N/A	0.625	1.469	2.219	0.875	B	S	1.02
10	3.680	3.236	2.611	N/A	N/A	0.625	1.750	2.547	1.000	B	S	1.50
11	4.000	3.549	2.888	N/A	N/A	0.625	1.875	2.625	1.000	B	S	1.68
12	4.330	3.864	3.239	N/A	N/A	0.625	2.250	3.063	1.000	B	S	2.22
13	4.660	4.179	3.523	N/A	N/A	0.625	2.250	3.250	1.000	B	S	2.56
14	4.980	4.494	3.869	N/A	N/A	0.625	2.250	3.250	1.000	B	S	2.72
15	5.300	4.810	4.158	N/A	N/A	0.625	2.250	3.250	1.000	B	S	2.90
16	5.630	5.126	4.501	0.594	1.38	0.625	2.250	3.250	1.000	B	D	3.10
17	5.950	5.442	4.794	0.594	1.66	0.625	2.250	3.250	1.000	B	D	3.40
18	6.270	5.759	5.134	0.594	1.88	0.625	2.250	3.250	1.000	B	D	3.56
19	6.590	6.076	5.430	0.594	2.06	0.625	2.250	3.250	1.000	B	D	3.72
20	6.910	6.392	5.768	0.719	2.40	0.750	2.375	3.500	1.125	B	D	4.72
21	7.240	6.710	6.066	0.719	2.62	0.750	2.375	3.500	1.125	B	D	4.84
22	7.560	7.027	6.402	0.719	2.88	0.750	2.375	3.500	1.125	B	D	5.04
23	7.880	7.344	6.702	0.719	3.14	0.750	2.375	3.500	1.125	B	D	5.18
24	8.200	7.661	7.036	0.719	3.22	0.750	2.375	3.500	1.125	B	D	5.58
25	8.520	7.979	7.338	0.719	3.50	0.750	2.375	3.500	1.125	B	D	5.96
26	8.840	8.296	7.671	0.719	3.74	0.750	2.375	3.500	1.125	B	D	6.22
28	9.480	8.931	8.307	0.719	4.76	0.750	2.375	3.500	1.125	B	D	6.78
30	10.110	9.567	8.942	0.719	5.08	0.750	2.375	3.500	1.125	B	D	7.56

\* Dimensions shown allow for standard keyway with set screw at 90 degrees

N/A = Non applicable/Not Available as standard

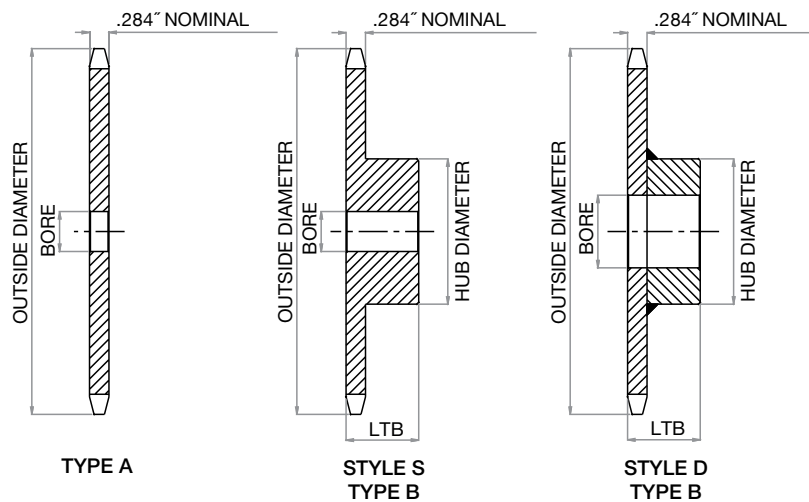

# HOW TO ORDER

TSUBAKI STOCK SPROCKETS



No.  
**2050**      **1 1/4" Pitch:**  
**DOUBLEPITCH**

Chain Data	
Size	2050
Pitch	1 1/4"
Inside Width	3/8"
Roller Diameter	0.400"
Nominal Tooth Width:	0.343"

How to Order Code: Example Model # for 2050 Pitch Plain Bore Carbon Steel Sprockets

Conveyor or Drive Series standard roller Double Pitch sprockets

For use with Tsubaki C2050/A2050 Chain - 1 1/4" Pitch

<b>A</b>	<b>2050</b>	<b>B</b>	<b>15</b>
----------	-------------	----------	-----------

Altered <sup>1</sup>	Chain Pitch in Inches	Hub Type	Number of Teeth				
			21	24	28		
A: Alteration Required	2050: 1 1/4" Pitch	A: No Hub Extension					
		B: Hub Extension One Side			30		

<sup>1</sup>Alteration field only to be denoted if a deviation from standard is required. Please reference Alterations in engineering section, page 182.

# No. 2050

## PLAIN BORE SPROCKET DIMENSIONS

Tsubaki Stock Sprockets

All dimensions in inches unless noted.

No. 2050 Plain Bore Sprocket Dia.				Type "A" Plain Bore		Type "B" Plain Bore						
No. Teeth	Outside Dia.	Pitch Dia.	Caliper Dia.	Plain Bore	Wt. Lbs.	Plain Bore	MAX Bore *	Hub Dia.	LTB	Hub Type	Hub Style	Wt. Lbs.
11	2.500	2.315	1.912	N/A	N/A	0.625	0.938	1.750	1.000	B	S	0.62
12	2.710	2.500	2.100	N/A	N/A	0.625	1.000	1.984	1.000	B	S	0.80
13	2.910	2.690	2.270	N/A	N/A	0.625	1.219	1.719	1.000	B	S	0.82
14	3.110	2.881	2.481	N/A	N/A	0.625	1.281	1.938	1.000	B	S	1.00
15	3.320	3.073	2.656	N/A	N/A	0.625	1.406	2.156	1.000	B	S	1.22
16	3.520	3.266	2.866	N/A	N/A	0.625	1.594	2.359	1.000	B	S	1.44
17	3.720	3.460	3.046	N/A	N/A	0.625	1.750	2.563	1.000	B	S	1.68
18	3.920	3.655	3.255	N/A	N/A	0.625	1.781	2.781	1.000	B	S	1.94
19	4.120	3.850	3.436	N/A	N/A	0.625	1.969	2.984	1.000	B	S	2.24
20	4.320	4.045	3.645	N/A	N/A	0.750	2.000	3.000	1.000	B	D	2.30
21	4.520	4.241	3.829	0.719	1.20	0.750	2.000	3.000	1.000	B	D	2.40
22	4.720	4.437	4.037	0.719	1.30	0.750	2.000	3.000	1.000	B	S	2.54
23	4.920	4.633	4.222	0.719	1.40	0.750	2.000	3.000	1.000	B	D	2.66
24	5.120	4.830	4.430	0.719	1.58	0.750	2.000	3.000	1.250	B	D	3.30
25	5.320	5.026	4.616	0.719	1.68	0.750	2.000	3.000	1.250	B	D	3.42
26	5.520	5.223	4.823	0.719	1.88	0.750	2.000	3.000	1.250	B	D	3.62
28	5.920	5.617	5.217	0.719	2.20	0.750	2.000	3.000	1.250	B	D	3.78
30	6.320	6.012	5.612	0.719	2.54	0.750	2.250	3.250	1.250	B	D	4.58

\* Dimensions shown allow for standard keyway with set screw at 90 degrees

N/A = Non applicable/Not Available as standard

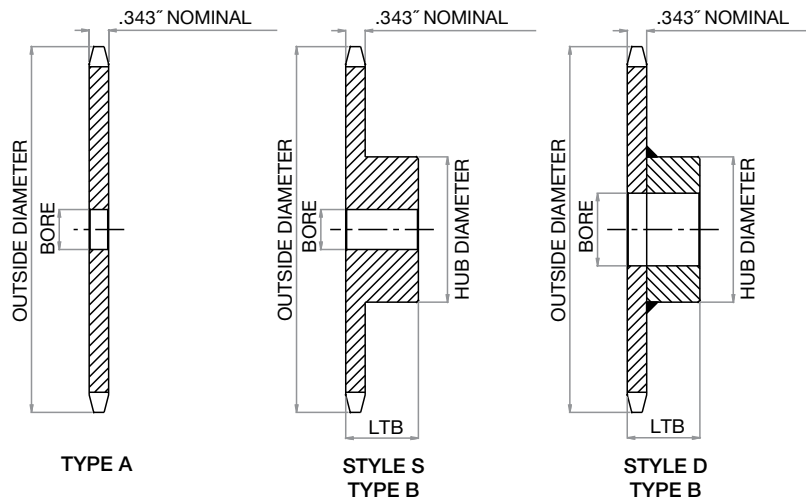

# HOW TO ORDER

TSUBAKI STOCK SPROCKETS



No. **2052**      **1 1/4" Pitch:**  
**DOUBLEPITCH**

Chain Data	
Size	2052
Pitch	1 1/4"
Inside Width	3/8"
Roller Diameter	0.750"
Nominal Tooth Width:	0.343"

How to Order Code: Example Model # for 2052 Pitch Plain Bore Carbon Steel Sprockets  
 Conveyor Series large roller Double Pitch sprockets  
 For use with Tsubaki C2052 Chain - 1 1/4" Pitch

<b>A</b>	<b>2052</b>	<b>B</b>	<b>17</b>
----------	-------------	----------	-----------

Altered <sup>11</sup>	Chain Pitch in Inches	Hub Type	Number of Teeth					
			12	18	24			
A: Alteration Required	2052: 1 1/4" Pitch	A: No Hub Extension						
		B: Hub Extension One Side						

<sup>11</sup>Alteration field only to be denoted if a deviation from standard is required. Please reference Alterations in engineering section, page 182.

# No. 2052

## PLAIN BORE SPROCKET DIMENSIONS

Tsubaki Stock Sprockets

All dimensions in inches unless noted.

No. 2052 Plain Bore Sprocket Dia.				Type "A" Plain Bore		Type "B" Plain Bore						
No. Teeth	Outside Dia.	Pitch Dia.	Caliper Dia.	Plain Bore	Wt. Lbs.	Plain Bore	MAX Bore *	Hub Dia.	LTB	Hub Type	Hub Style	Wt. Lbs.
8	3.770	3.266	2.516	N/A	N/A	0.625	1.594	2.359	1.000	B	S	1.38
9	4.190	3.655	2.850	N/A	N/A	0.625	1.781	2.781	1.000	B	S	1.92
10	4.600	4.045	3.295	N/A	N/A	0.625	2.000	3.000	1.000	B	S	2.30
11	5.010	4.437	3.642	N/A	N/A	0.625	2.000	3.000	1.000	B	S	2.54
12	5.420	4.830	4.080	0.719	1.58	0.750	2.000	3.000	1.250	B	D	3.20
13	5.820	5.223	4.435	0.719	1.82	0.750	2.000	3.000	1.250	B	D	3.48
14	6.230	5.617	4.867	0.719	2.28	0.750	2.000	3.000	1.250	B	D	3.88
15	6.630	6.012	5.229	0.719	2.46	0.750	2.250	3.250	1.250	B	D	4.46
16	7.030	6.407	5.657	0.719	2.88	0.750	2.250	3.250	1.250	B	D	4.80
17	7.440	6.803	6.024	0.719	3.28	0.750	2.250	3.250	1.250	B	D	5.34
18	7.840	7.198	6.448	0.719	3.64	0.750	2.250	3.250	1.250	B	D	5.64
19	8.240	7.595	6.819	0.719	4.12	0.750	2.250	3.250	1.250	B	D	6.04
20	8.640	7.991	7.241	0.719	4.72	0.750	2.250	3.250	1.250	B	D	6.48
21	9.040	8.387	7.614	0.719	5.08	0.750	2.250	3.250	1.250	B	D	7.00
22	9.440	8.783	8.033	0.719	5.20	0.750	2.250	3.250	1.250	B	D	7.30
23	9.850	9.180	8.409	0.938	5.84	1.000	2.750	3.750	1.250	B	D	8.66
24	10.250	9.577	8.827	0.938	6.70	0.938	2.750	3.750	1.250	B	D	9.32
25	10.650	9.973	9.204	0.938	7.54	0.938	2.750	3.750	1.250	B	D	10.30
26	11.050	10.370	9.620	0.938	8.24	0.938	2.750	3.750	1.250	B	D	11.00
28	11.840	11.164	10.414	0.938	8.70	0.938	2.750	3.750	1.250	B	D	11.70
30	12.640	11.958	11.208	0.938	9.92	0.938	2.750	3.750	1.250	B	D	12.90

\* Dimensions shown allow for standard keyway with set screw at 90 degrees

N/A = Non applicable/Not Available as standard

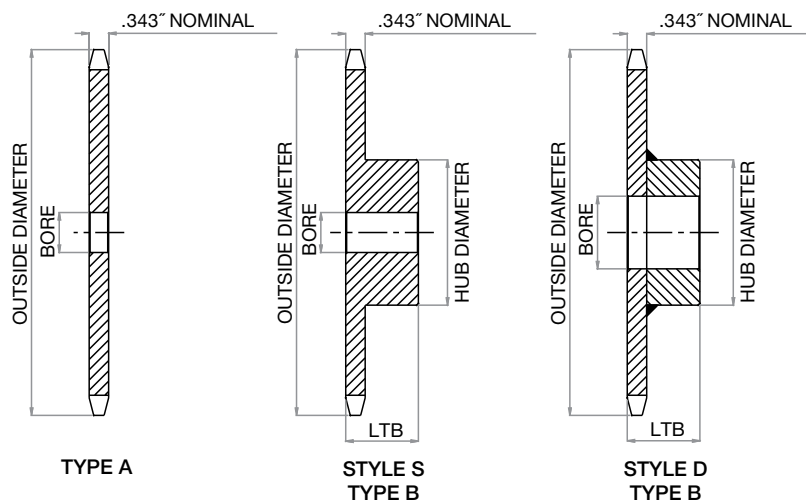



# HOW TO ORDER

TSUBAKI STOCK SPROCKETS



No.  
**2060**

**1½" Pitch:  
DOUBLEPITCH**

Chain Data	
Size	2060
Pitch	1 1/2"
Inside Width	1/2"
Roller Diameter	0.469"
Nominal Tooth Width:	0.459"

How to Order Code: Example Model # for 2060 Pitch Plain Bore Carbon Steel Sprockets

Conveyor or Drive Series standard roller Double Pitch sprockets

For use with Tsubaki C2060/A2060 Chain - 1 1/2" Pitch

<b>A</b>	<b>2060</b>	<b>B</b>	<b>13</b>
----------	-------------	----------	-----------

Altered <sup>1</sup>	Chain Pitch in Inches	Hub Type	Number of Teeth			
			19	23	28	
A: Alteration Required	2060: 1½" Pitch	A: No Hub Extension	20	24	30	
			21	25		
			22	26		
			11	17	23	
		B: Hub Extension One Side	12	18	24	
			13	19	25	
			14	20	26	
			15	21	28	
			16	22	30	

<sup>1</sup>Alteration field only to be denoted if a deviation from standard is required. Please reference Alterations in engineering section, page 182.

# No. 2060

## PLAIN BORE SPROCKET DIMENSIONS

Tsubaki Stock Sprockets

All dimensions in inches unless noted.

No. 2060 Plain Bore Sprocket Dia.				Type "A" Plain Bore		Type "B" Plain Bore						
No. Teeth	Outside Dia.	Pitch Dia.	Caliper Dia.	Plain Bore	Wt. Lbs.	Plain Bore	MAX Bore *	Hub Dia.	LTB	Hub Type	Hub Style	Wt. Lbs.
11	3.000	2.773	2.276	N/A	N/A	0.750	1.000	2.063 "	1.250	B	S	1.14
12	3.250	3.000	2.531	N/A	N/A	0.750	1.250	2.375 "	1.250	B	S	1.46
13	3.490	3.228	2.735	N/A	N/A	0.750	1.313	2.078	1.250	B	S	1.52
14	3.740	3.457	2.988	N/A	N/A	0.750	1.563	2.328	1.250	B	S	1.86
15	3.980	3.688	3.199	N/A	N/A	0.750	1.750	2.594	1.250	B	S	2.24
16	4.220	3.920	3.451	N/A	N/A	0.750	1.844	2.844	1.250	B	S	2.64
17	4.460	4.152	3.666	N/A	N/A	0.750	2.094	3.094	1.250	B	S	3.08
18	4.700	4.386	3.917	N/A	N/A	0.750	2.281	3.344	1.250	B	S	3.56
19	4.940	4.620	4.135	0.719	2.10	0.750	2.344	3.500	1.250	B	D	3.94
20	5.190	4.854	4.385	0.719	2.40	0.750	2.563	3.875	1.250	B	D	4.50
21	5.430	5.089	4.606	0.719	2.50	0.750	2.750	4.000	1.250	B	D	5.02
22	5.670	5.324	4.855	0.719	2.70	0.750	2.750	4.000	1.250	B	D	5.26
23	5.910	5.560	5.077	0.719	3.00	0.750	2.750	4.000	1.250	B	D	5.54
24	6.150	5.796	5.327	0.719	3.02	0.750	2.750	4.000	1.250	B	D	5.90
25	6.390	6.032	5.551	0.719	3.36	0.750	2.750	4.000	1.250	B	D	6.08
26	6.630	6.268	5.799	0.719	3.58	0.750	2.750	4.000	1.250	B	D	6.36
28	7.110	6.741	6.272	0.719	4.12	0.750	2.750	4.000	1.250	B	D	7.02
30	7.590	7.215	6.746	0.719	4.88	0.750	2.750	4.000	1.250	B	D	7.54

\* Dimensions shown allow for standard keyway with set screw at 90 degrees

" Has recessed groove in hub for chain clearance

N/A = Non applicable/Not Available as standard

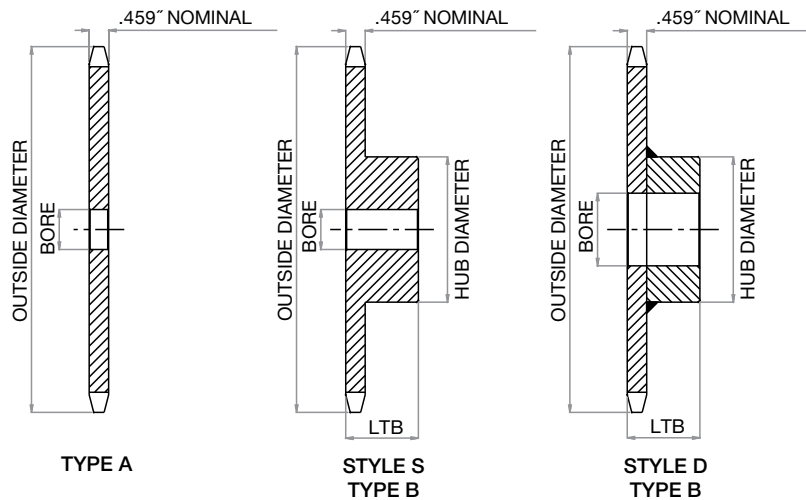

# HOW TO ORDER

TSUBAKI STOCK SPROCKETS



No.  
**2062**

**1½" Pitch:  
DOUBLEPITCH**

Chain Data	
Size	2062
Pitch	1 1/2"
Inside Width	3/8"
Roller Diameter	0.875"
Nominal Tooth Width:	0.459"

How to Order Code: Example Model # for 2062 Pitch Plain Bore Carbon Steel Sprockets

Conveyor Series large roller Double Pitch sprockets

For use with Tsubaki C2062/A2062 Chain - 1 1/2" Pitch

<b>A</b>	<b>2062</b>	<b>B</b>	<b>11</b>
----------	-------------	----------	-----------

Altered <sup>1</sup>	Chain Pitch in Inches	Hub Type	Number of Teeth					
			12	18	24			
A: Alteration Required	2062: 1½" Pitch	A: No Hub Extension						
		B: Hub Extension One Side						

<sup>1</sup>Alteration field only to be denoted if a deviation from standard is required. Please reference Alterations in engineering section, page 182.

All dimensions in inches unless noted.

No. 2062 Plain Bore Sprocket Dia.				Type "A" Plain Bore		Type "B" Plain Bore						
No. Teeth	Outside Dia.	Pitch Dia.	Caliper Dia.	Plain Bore	Wt. Lbs.	Plain Bore	MAX Bore *	Hub Dia.	LTB	Hub Type	Hub Style	Wt. Lbs.
8	4.520	3.920	3.045	N/A	N/A	0.750	1.844	2.844	1.250	B	S	2.60
9	5.020	4.386	3.444	N/A	N/A	0.750	2.281	3.344	1.250	B	S	3.48
10	5.520	4.854	3.979	N/A	N/A	0.750	2.563	3.828	1.250	B	S	4.54
11	6.010	5.324	4.395	N/A	N/A	0.750	2.750	4.000	1.250	B	S	5.20
12	6.500	5.796	4.921	0.719	2.98	0.750	2.750	4.000	1.250	B	D	5.70
13	6.990	6.268	5.347	0.719	3.60	0.750	2.750	4.000	1.250	B	D	6.28
14	7.470	6.741	5.866	0.719	4.02	0.750	2.750	4.000	1.250	B	D	6.82
15	7.960	7.215	6.300	0.719	4.76	0.750	2.750	4.000	1.250	B	D	7.48
16	8.440	7.689	6.814	0.719	5.70	0.750	2.750	4.000	1.250	B	D	8.18
17	8.920	8.163	7.253	0.938	6.16	1.000	2.750	4.000	1.250	B	D	8.82
18	9.410	8.638	7.763	0.938	6.96	1.000	2.750	4.000	1.250	B	D	9.36
19	9.890	9.113	8.207	0.938	8.00	1.000	2.750	4.250	1.250	B	D	11.10
20	10.370	9.589	8.714	0.938	8.46	0.938	2.750	4.250	1.250	B	D	11.66
21	10.850	10.064	9.161	0.938	8.93	0.938	2.750	4.250	1.250	B	D	13.24
22	11.330	10.540	9.665	0.938	10.74	0.938	2.750	4.250	1.250	B	D	13.78
23	11.810	11.016	10.115	0.938	11.64	0.938	2.750	4.250	1.250	B	D	14.90
24	12.290	11.492	10.617	0.938	12.64	0.938	2.750	4.250	1.250	B	D	15.56
25	12.770	11.968	11.070	0.938	13.78	0.938	2.750	4.250	1.250	B	D	16.80
26	13.250	12.444	11.569	0.938	15.00	0.938	2.750	4.250	1.750	B	D	20.20
28	14.210	13.397	12.522	1.250	17.32	1.250	2.750	4.250	1.750	B	D	21.86
30	15.170	14.350	13.475	1.250	19.50	1.250	2.750	4.250	1.750	B	D	26.00

\* Dimensions shown allow for standard keyway with set screw at 90 degrees

N/A = Non applicable/Not Available as standard

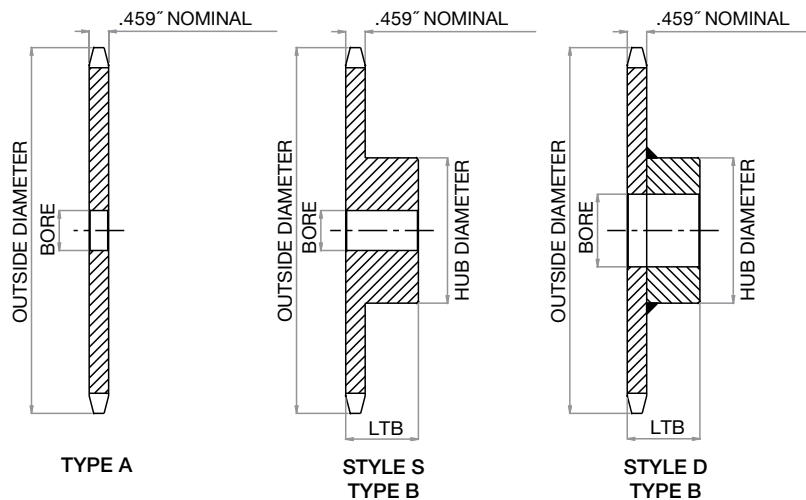

# HOW TO ORDER

TSUBAKI STOCK SPROCKETS



No. **2080**      2" Pitch:  
**DOUBLEPITCH**

Chain Data	
Size	2080
Pitch	2"
Inside Width	5/8"
Roller Diameter	0.625"
Nominal Tooth Width:	0.575"

How to Order Code: Example Model # for 2080 Pitch Plain Bore Carbon Steel Sprockets  
 Conveyor Series large roller Double Pitch sprockets  
 For use with Tsubaki C2080/A2080 Chain - 2" Pitch

<b>A</b>	<b>2080</b>	<b>B</b>	<b>20</b>				
Altered <sup>11</sup>	Chain Pitch in Inches	Hub Type	Number of Teeth				
A: Alteration Required	2080: 2" Pitch	A: No Hub Extension	16	21	26		
			17	22	28		
			18	23	30		
			19	24			
			20	25			
		B: Hub Extension One Side	11	17	23		
			12	18	24		
			13	19	25		
			14	20	26		
			15	21	28		
			16	22	30		

<sup>11</sup>Alteration field only to be denoted if a deviation from standard is required. Please reference Alterations in engineering section, page 182.

# No. 2080

## PLAIN BORE SPROCKET DIMENSIONS

Tsubaki Stock Sprockets

All dimensions in inches unless noted.

No. 2080 Plain Bore Sprocket Dia.				Type "A" Plain Bore		Type "B" Plain Bore						
No. Teeth	Outside Dia.	Pitch Dia.	Caliper Dia.	Plain Bore	Wt. Lbs.	Plain Bore	MAX Bore *	Hub Dia.	LTB	Hub Type	Hub Style	Wt. Lbs.
11	4.010	3.694	3.074	N/A	N/A	1.000	1.500	2.813 "	1.625	B	S	2.50
12	4.330	4.000	3.375	N/A	N/A	1.000	1.688	3.125 "	1.625	B	S	3.20
13	4.660	4.304	3.647	N/A	N/A	1.000	1.781	2.781	1.500	B	S	3.20
14	4.980	4.610	3.985	N/A	N/A	1.000	2.125	3.125	1.500	B	S	4.00
15	5.300	4.917	4.265	N/A	N/A	1.000	2.281	3.453	1.500	B	S	4.80
16	5.630	5.226	4.601	0.938	3.10	1.000	2.531	3.797	1.500	B	D	5.70
17	5.960	5.536	4.888	0.938	3.40	1.000	2.750	4.000	1.500	B	D	6.40
18	6.270	5.848	5.223	0.938	3.80	1.000	2.750	4.250	1.500	B	D	7.40
19	6.590	6.160	5.513	0.938	4.30	1.000	2.750	4.250	1.500	B	D	7.70
20	6.910	6.472	5.845	0.938	4.80	1.000	2.750	4.250	1.500	B	D	8.30
21	7.230	6.785	6.141	0.938	5.30	1.000	2.750	4.250	1.750	B	D	9.40
22	7.560	7.099	6.474	0.938	5.80	1.000	2.750	4.250	1.750	B	D	10.00
23	7.880	7.413	6.770	0.938	6.40	1.000	2.750	4.250	1.750	B	D	10.50
24	8.200	7.727	7.102	0.938	7.10	1.000	2.750	4.250	1.750	B	D	11.10
25	8.520	8.042	7.401	0.938	7.50	1.000	2.750	4.250	1.750	B	D	12.00
26	8.840	8.357	7.732	1.188	8.30	1.250	3.250	4.750	2.000	B	D	14.80
28	9.480	8.988	8.363	1.188	9.20	1.188	3.250	4.750	2.000	B	D	16.60
30	10.110	9.620	8.995	1.188	10.70	1.188	3.250	4.750	2.000	B	D	17.80

\* Dimensions shown allow for standard keyway with set screw at 90 degrees

" Has recessed groove in hub for chain clearance

N/A = Non applicable/Not Available as standard

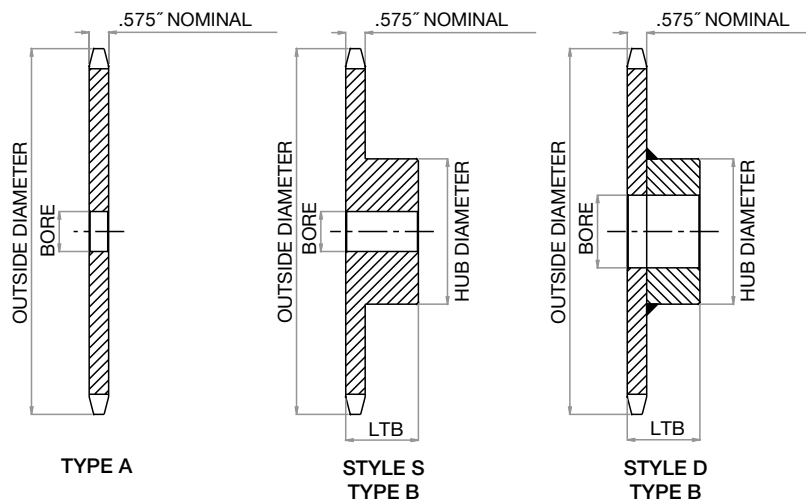

# HOW TO ORDER

TSUBAKI STOCK SPROCKETS



No.  
**2082**      2" Pitch:  
**DOUBLEPITCH**

Chain Data	
Size	2082
Pitch	2"
Inside Width	5/8"
Roller Diameter	1.125"
Nominal Tooth Width:	0.575"

How to Order Code: Example Model # for 2082 Pitch Plain Bore Carbon Steel Sprockets  
 Conveyor Series large roller Double Pitch sprockets  
 For use with Tsubaki C2082/A2082 Chain - 2" Pitch

A	2082	B	28			
Altered <sup>1</sup>	Chain Pitch in Inches	Hub Type	Number of Teeth			
A: Alteration Required	2082: 2" Pitch	A: No Hub Extension	11	17	23	
			12	18	24	
			13	19	25	
			14	20	26	
			15	21	28	
			16	22	30	
		B: Hub Extension One Side	8	14	20	26
			9	15	21	28
			10	16	22	30
			11	17	23	
			12	18	24	
			13	19	25	

<sup>1</sup>Alteration field only to be denoted if a deviation from standard is required. Please reference Alterations in engineering section, page 182.

# No. 2082

## PLAIN BORE SPROCKET DIMENSIONS

Tsubaki Stock Sprockets

All dimensions in inches unless noted.

No. 2082 Plain Bore Sprocket Dia.				Type "A" Plain Bore		Type "B" Plain Bore						
No. Teeth	Outside Dia.	Pitch Dia.	Caliper Dia.	Plain Bore	Wt. Lbs.	Plain Bore	MAX Bore *	Hub Dia.	LTB	Hub Type	Hub Style	Wt. Lbs.
8	6.030	5.226	4.101	N/A	N/A	1.000	2.531	3.797	1.750	B	S	6.40
9	6.700	5.848	4.634	N/A	N/A	1.000	2.750	4.250	1.750	B	S	8.20
10	7.360	6.472	5.347	N/A	N/A	1.000	2.750	4.250	1.750	B	S	9.20
11	8.010	7.099	5.902	0.938	5.70	1.000	2.750	4.250	1.750	B	D	10.10
12	8.660	7.727	6.602	0.938	6.80	1.000	2.750	4.250	1.750	B	D	11.20
13	9.310	8.357	7.171	1.188	7.70	1.250	3.250	4.750	2.000	B	D	15.00
14	9.960	8.988	7.863	1.188	9.10	1.250	3.250	4.750	2.000	B	D	15.80
15	10.610	9.620	8.442	1.188	10.70	1.188	3.250	4.750	2.000	B	D	17.80
16	11.250	10.252	9.127	1.188	12.40	1.188	3.250	4.750	2.000	B	D	19.30
17	11.900	10.885	9.713	1.188	14.10	1.188	3.250	4.750	2.000	B	D	21.40
18	12.540	11.512	10.393	1.188	15.40	1.188	3.250	4.750	2.000	B	D	22.90
19	13.190	12.151	10.985	1.188	18.00	1.188	3.250	4.750	2.000	B	D	24.40
20	13.830	12.785	11.660	1.188	19.20	1.188	3.250	4.750	2.000	B	D	26.70
21	14.470	13.419	12.256	1.250	20.80	1.250	3.250	4.750	2.000	B	D	28.40
22	15.110	14.053	12.928	1.250	23.70	1.250	3.250	4.750	2.000	B	D	32.20
23	15.750	14.688	13.528	1.250	24.90	1.250	3.250	4.750	2.000	B	D	34.90
24	16.390	15.323	14.198	1.250	27.60	1.250	3.250	4.750	2.000	B	D	37.80
25	17.030	15.958	14.801	1.250	30.20	1.250	3.250	4.750	2.000	B	D	39.60
26	17.670	16.593	15.468	1.250	32.80	1.250	3.500	5.250	2.000	B	D	41.50
28	18.950	17.863	16.738	1.250	38.60	1.250	3.500	5.250	2.000	B	D	47.70
30	20.230	19.134	18.009	1.250	43.80	1.250	3.500	5.250	2.000	B	D	54.50

\* Dimensions shown allow for standard keyway with set screw at 90 degrees

N/A = Non applicable/Not Available as standard

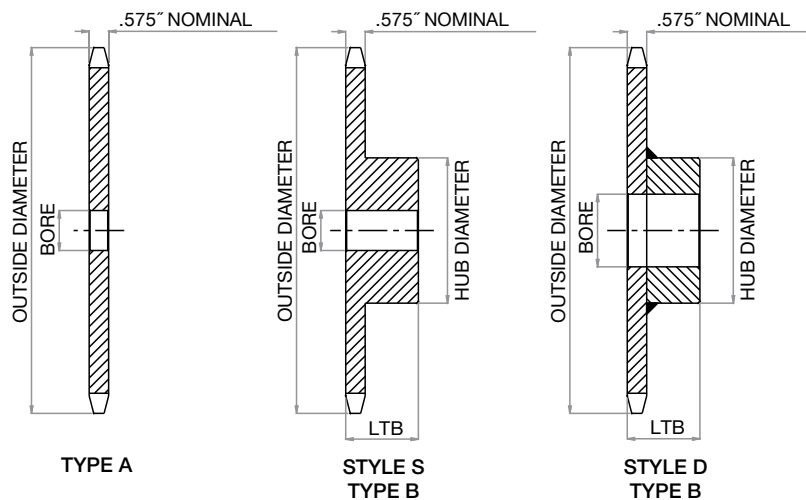





# DOUBLE PLUS SPROCKETS

How to Order Code: Example Model # for Double Plus Carbon Steel Sprockets  
Sprockets for Tsubaki Double Plus Chain Series VR, VRP, VR-SC and VRP-SC

<b>A</b>	<b>C2040</b>	<b>VRP</b>	<b>-10</b>
Altered <sup>!!</sup>	Double Plus Chain Pitch	Chain Type:	Number of Teeth*
A: Alteration Required	C2030	VRP: Plastic Roller Type	10: 10 Teeth
	C2040		
	C2050		
	C2060		
	C2080		

<sup>!!</sup>Alteration field only to be denoted if a deviation from standard is required. Please reference Alterations in engineering section, page 182.

\* Number of Teeth\*: Double Plus sprockets are available in 10 tooth configuration only as stock. Please consult factory for other options.

Dimensional data in inches unless noted.

No. Teeth	Chain Pitch	Outside Dia. (Do)	Pitch Dia. (Dp)	Plain Bore (d)	Hub Dia. (DH)	Hub Length (L)	Hub Type	Tooth Thickness (T)	M	Wt. Lbs.
10	C2030	2.480	2.427	0.500	1.457	0.984	B	0.118	0.602	0.44
10	C2040	3.346	3.326	0.630	2.047	1.575	B	0.157	0.803	1.76
10	C2050	4.213	4.045	0.630	2.598	1.772	B	0.197	1.004	3.31
10	C2060	5.039	4.854	0.748	3.189	1.969	B	0.236	1.201	5.52
10	C2080	6.772	6.472	0.906	4.331	2.638	B	0.472	1.870	15.40

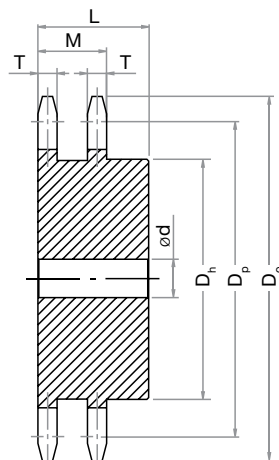



# BUSHINGS, HUBS, IDLERS AND CHAIN TENSIONERS

## **Bushings, Hubs, Idlers and Chain Tensioners**

**163**

TAPER-LOCK® Bushings	164 - 167
TAPER-LOCK® Weld-On Hubs	168 - 169
QD® Bushings	170 - 173
QD® Weld-On Hubs	174 - 175
Idler Sprockets	176 - 178
Chain Tensioners	179 - 180

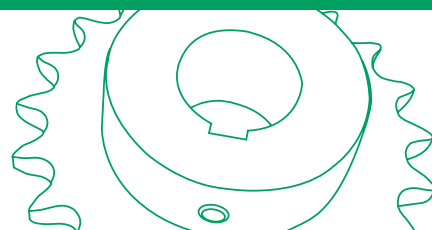



# TAPER-LOCK® BUSHINGS

How to Order Code: Example Model # for TAPER-LOCK® Bushings

A	2517	-1B
---	------	-----

Altered <sup>!!</sup>	Bushing Number	Bore Size		
A: Alteration Required	1008	Blank = stock plain bore		
	1108	H	1/2"	(0.500")
	1210	I	9/16"	(0.563")
	1215	J	5/8"	(0.625")
	1310	K	11/16"	(0.688")
	1610	L	3/4"	(0.750")
	1615	M	13/16"	(0.813")
	2012	P	7/8"	(0.875")
	2517	R	15/16"	(0.938")
	2525	1	1"	(1.000")
	3020	1A	1-1/16"	(1.063")
	3030	1B	1-1/8"	(1.125")
	3535			
	4040			
	4545			
5050				

Above are examples.  
There are more sizes available.  
See chart on page 166.

<sup>!!</sup> Alteration field only to be denoted if a deviation from standard is required. Please reference Alterations in engineering section, page 182.

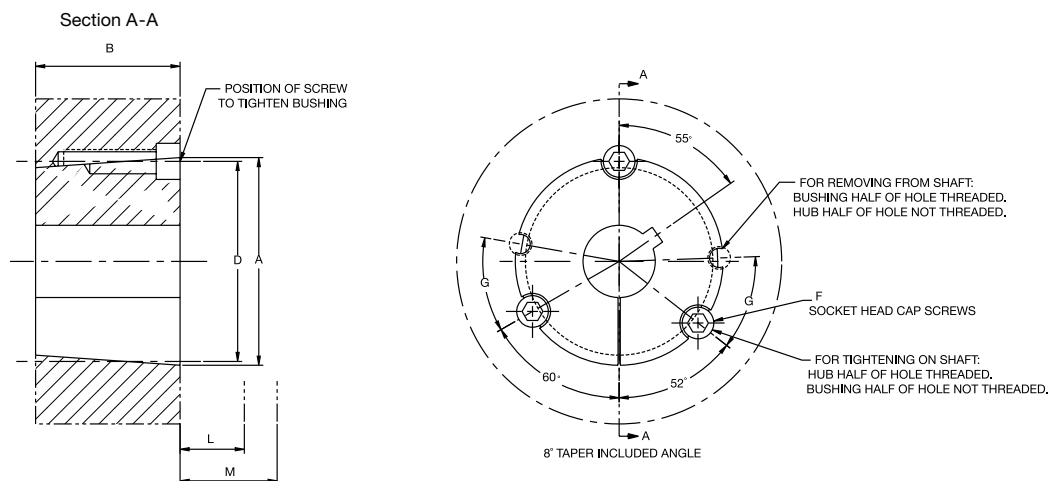

# TAPER-LOCK® BUSHINGS DIMENSIONS

All dimensions in inches unless noted.

Bushing No.	Bore Range				Torque Capacity (lb-in)	A	B	C	Wt. Lbs*
	Minimum	Max w/ Standard Keyway	Max w/ Shallow Keyway	Max w/No Keyway					
1008	0.500	0.875	1.000	1.000	1,200	1.386	0.875	1.328	0.20
1108	0.500	1.000	1.125	1.125	1,300	1.511	0.875	1.453	0.25
1210	0.500	1.250	1.250	1.250	3,600	1.875	1.000	1.750	0.55
1215	0.500	1.250	1.250	1.250	3,550	1.875	1.500	1.750	0.70
1310	0.500	1.375	1.438	1.438	3,850	2.000	1.000	1.875	0.70
1610	0.500	1.625	1.688	1.688	4,300	2.250	1.000	2.125	0.75
1615	0.500	1.625	1.688	1.688	4,300	2.250	1.500	2.125	1.00
2012	0.500	2.000	2.125	2.125	7,150	2.750	1.250	2.625	1.40
2517	0.500	2.438	2.688	2.688	11,600	3.375	1.750	3.250	3.20
2525	0.750	2.375	2.688	2.688	11,300	3.375	2.500	3.250	4.30
3020	0.875	3.000	3.250	3.250	24,000	4.250	2.000	4.000	5.80
3030	0.938	3.000	3.250	3.250	24,000	4.250	3.000	4.000	8.00
3535	1.188	3.500	3.938	3.938	44,800	5.000	3.500	4.830	11.00
4040	1.438	4.000	4.438	4.438	77,300	5.750	4.000	5.540	17.00
4545	1.938	4.500	4.938	4.938	110,000	6.375	4.500	6.130	24.00
5050	2.438	5.000	5.313	5.313	126,000	7.000	5.000	6.720	32.00

\* Bushing weight changes with bore size. Weight depicted reflects approximate weight.

NOTE: Torque Capacity shown is for light starting and steady running. For more sever applications apply Service Factor as needed.

All dimensions in inches unless noted.

Bushing No.	Locking Screws (F)		Clearance L*		Clearance M#		Hex Key Torque in./lbs
	Size	Qt.	Std. Hey Key	Short Hex Key	Std. Hey Key	Short Hex Key	
1008	.250 X .500	2	1.125	0.625	1.250	0.750	55
1108	.250 X .500	2	1.125	0.625	1.250	0.750	55
1210	.375 X .625	2	1.375	0.813	1.625	1.063	175
1215	.375 X .625	2	1.375	0.813	1.625	1.063	175
1310	.375 X .625	2	1.375	0.813	1.625	1.063	175
1610	.375 X .625	2	1.375	0.813	1.625	1.063	175
1615	.375 X .625	2	1.375	0.813	1.625	1.063	175
2012	.438 X .875	2	1.563	0.938	2.000	1.375	280
2517	.500 X 1.000	2	1.625	1.000	2.250	1.625	430
2525	.500 X 1.000	2	1.625	1.000	2.250	1.625	430
3020	.625 X 1.250	2	1.813	1.188	2.688	2.063	800
3030	.625 X 1.250	2	1.813	1.188	2.688	2.063	800
3535	.500 X 1.500	3	2.000	1.313	3.375	2.688	1000
4040	.625 X 1.750	3	2.375	1.625	4.125	3.375	1700
4545	.750 X 2.000	3	2.625	1.938	4.750	4.063	2450
5050	.875 X 2.250	3	2.813	2.313	5.250	4.813	3100

\* Space required to tighten bushing. Also space required to loosen screws to permit removal of hub by puller.

# Space required to remove bushing using jackscrews - no puller required

Short Hex Key = Standard hex key cut to minimum usable length.

# TAPER-LOCK® BUSHINGS

Bore Size in Inches	Item Code	Bushing Number															
		1008	1108	1210	1215	1310	1610	1615	2012	2517	2525	3020	3030	3535	4040	4545	5050
1/2"	H	.	.	.	.	.	.	.	.	.	.	.	.	.	.	.	.
9/16"	I	.	.	.	.	.	.	.	.	.	.	.	.	.	.	.	.
5/8"	J	.	.	.	.	.	.	.	.	.	.	.	.	.	.	.	.
11/16"	K	.	.	.	.	.	.	.	.	.	.	.	.	.	.	.	.
3/4"	L	.	.	.	.	.	.	.	.	.	.	.	.	.	.	.	.
13/16"	M	.	.	.	.	.	.	.	.	.	.	.	.	.	.	.	.
7/8"	P	.	.	.	.	.	.	.	.	.	.	.	.	.	.	.	.
15/16"	R	S	.	.	.	.	.	.	.	.	.	.	.	.	.	.	.
1"	1	S	.	.	.	.	.	.	.	.	.	.	.	.	.	.	.
1-1/16"	1A		S	.	.	.	.	.	.	.	.	.	.	.	.	.	.
1-1/8"	1B		S	.	.	.	.	.	.	.	.	.	.	.	.	.	.
1-3/16"	1C			.	.	.	.	.	.	.	.	.	.	.	.	.	.
1-1/4"	1D			.	.	.	.	.	.	.	.	.	.	.	.	.	.
1-5/16"	1E			.	.	.	.	.	.	.	.	.	.	.	.	.	.
1-3/8"	1F			.	.	.	.	.	.	.	.	.	.	.	.	.	.
1-7/16"	1G			.	.	.	.	.	.	.	.	.	.	.	.	.	.
1-1/2"	1H			.	.	.	.	.	.	.	.	.	.	.	.	.	.
1-9/16"	1I			.	.	.	.	S	S	.	.	.	.	.	.	.	.
1-5/8"	1J			.	.	.	.	S	S	.	.	.	.	.	.	.	.
1-11/16"	1K			.	.	.	.	S	S	.	.	.	.	.	.	.	.
1-3/4"	1L			.	.	.	.	.	.	.	.	.	.	.	.	.	.
1-13/16"	1M			.	.	.	.	.	.	.	.	.	.	.	.	.	.
1-7/8"	1P			.	.	.	.	.	.	.	.	.	.	.	.	.	.
1-15/16"	1R			.	.	.	.	.	S	.	.	.	.	.	.	.	.
2"	2			.	.	.	.	.	S	.	.	.	.	.	.	.	.
2-1/16"	2A			.	.	.	.	.	.	.	.	.	.	.	.	.	.
2-1/8"	2B			.	.	.	.	.	S	.	.	.	.	.	.	.	.
2-3/16"	2C			.	.	.	.	.	.	.	.	.	.	.	.	.	.
2-1/4"	2D			.	.	.	.	.	.	.	.	.	.	.	.	.	.
2-5/16"	2E			.	.	.	.	.	.	S	S	.	.	.	.	.	.
2-3/8"	2F			.	.	.	.	.	.	S	S	.	.	.	.	.	.
2-7/16"	2G			.	.	.	.	.	.	S	S	.	.	.	.	.	.
2-1/2"	2H			.	.	.	.	.	.	S	S	.	.	.	.	.	.
2-9/16"	2I			.	.	.	.	.	.	.	.	.	.	.	.	.	.
2-5/8"	2J			.	.	.	.	.	.	S	.	.	.	.	.	.	.
2-11/16"	2K			.	.	.	.	.	.	S	.	.	.	.	.	.	.
2-3/4"	2L			.	.	.	.	.	.	.	.	.	.	.	.	.	.
2-13/16"	2M			.	.	.	.	.	.	.	S	.	.	.	.	.	.
2-7/8"	2P			.	.	.	.	.	.	.	S	S	.	.	.	.	.
2-15/16"	2R			.	.	.	.	.	.	.	S	S	.	.	.	.	.
3"	3			.	.	.	.	.	.	.	S	S	.	.	.	.	.
3-1/8"	3B			.	.	.	.	.	.	.	S	S	.	.	.	.	.
3-3/16"	3C			.	.	.	.	.	.	.	S	S	.	.	.	.	.
3-1/4"	3D			.	.	.	.	.	.	.	S	S	.	.	.	.	.
3-5/16"	3E			.	.	.	.	.	.	.	.	.	S	.	.	.	.
3-3/8"	3F			.	.	.	.	.	.	.	.	.	S	.	.	.	.
3-7/16"	3G			.	.	.	.	.	.	.	.	.	S	.	.	.	.
3-1/2"	3H			.	.	.	.	.	.	.	.	.	S	.	.	.	.
3-5/8"	3J			.	.	.	.	.	.	.	.	.	S	.	.	.	.
3-11/16"	3K			.	.	.	.	.	.	.	.	.	S	S	.	.	.
3-3/4"	3L			.	.	.	.	.	.	.	.	.	S	S	.	.	.
3-7/8"	3P			.	.	.	.	.	.	.	.	.	S	S	.	.	.
3-15/16"	3R			.	.	.	.	.	.	.	.	.	S	S	.	.	.
4"	4			.	.	.	.	.	.	.	.	.	.	S	.	.	.
4-1/8"	4B			.	.	.	.	.	.	.	.	.	.	S	.	.	.
4-3/16"	4C			.	.	.	.	.	.	.	.	.	.	.	.	.	.
4-1/4"	4D			.	.	.	.	.	.	.	.	.	.	S	.	.	.
4-3/8"	4F			.	.	.	.	.	.	.	.	.	.	.	.	.	.
4-7/16"	4G			.	.	.	.	.	.	.	.	.	.	S	.	.	.
4-1/2"	4H			.	.	.	.	.	.	.	.	.	.	.	.	S	.
4-3/4"	4P			.	.	.	.	.	.	.	.	.	.	.	.	S	S
4-15/16"	4R			.	.	.	.	.	.	.	.	.	.	.	.	S	S
5"	5			.	.	.	.	.	.	.	.	.	.	.	.	.	S

See page 194 for Shallow keyway dimensions.

• Denotes stocking item

S = Shallow keyway in hub

# TAPER-LOCK®

## BUSHING INSTALLATION AND REMOVAL

### TAPER-LOCK® Bushing Installation

- 1 Clean and degrease the bore and tapered surface of the bushing and the tapered bore of the pulley/hub/sprocket.
- 2 Insert the bushing into the pulley/hub/sprocket bore and line up the holes (Half threaded holes must line up the half straight non-threaded holes).
- 3 Lightly oil the locking screws and insert but do not tighten yet.
- 4 When using a key, it should be fitted to the shaft keyway. There should be a top clearance between the key and the keyway in the mating bushing.
- 5 Clean and degrease the shaft. Fit pulley/hub/sprocket onto the shaft and locate in the desired position.
- 6 Using a hexagon socket wrench, gradually tighten the locking screws in accordance with the required tightening torque.
- 7 When the drive has been operating under load for a short period, approximately 30 to 60 minutes, stop the equipment and check that the screws remain at the required tightening torque. Adjust if necessary.
- 8 To avoid the ingress of dirt, fill all empty holes with grease.

### TAPER-LOCK® Bushing Removal

- A Remove any loading to the equipment to enable a safe removal of components.
- B Slacken and remove all locking screws.
- C Add lubricant to the previously removed screws and insert into jack-out hole/holes in the bushing.
- D Tighten the screws uniformly and alternately until the bushing is loose and the pulley/hub/sprocket can be moved freely on the shaft.
- E Remove the bushing/pulley/hub/sprocket assembly from the shaft.

# TAPER-LOCK® WELD-ON HUBS

Tsubaki offers the most complete line of TAPER-LOCK® weld-on hubs for insertion and welding to produce “B” type sprockets, sheaves, and other applications without hub protrusion. To provide greater strength for this type of shaft locking mechanism and to reduce heat distortion caused by welding, these hubs are dimensionally interchangeable with our sprocket items.

Special dimension hubs are available per your application requirements on a Made-To-Order basis. All stock Tsubaki hubs are made from 1045 steel bar stock. No powdered or sintered metal is used. The TAPER-LOCK® weld-on hubs listed below include the appropriate tapered bores and mounting holes to mate with Tsubaki sprockets and other sprocket manufactures that conform to ANSI specifications.

## TAPER-LOCK® WELD-ON HUBS

All dimensions in inches unless noted.

Model #	Use with Bushing #	D	P	L	T	Wt. Lbs
35TL1	1610	3.000	2.875	1.000	0.141	0.80
41TL1	1610	3.000	2.875	1.000	0.219	0.80
40TL1	1610	3.000	2.875	1.000	0.250	0.80
40TL2	2012	3.625	3.438	1.250	0.250	1.50
40TL3	2517	4.250	4.125	1.750	0.250	2.70
50TL1	2012	3.625	3.438	1.250	0.313	1.50
50TL2	2517	4.250	4.125	1.750	0.313	2.70
60TL1	2012	3.625	3.438	1.250	0.438	1.50
60TL2	2517	4.250	4.125	1.750	0.438	2.70
80TL1	2012	3.625	3.438	1.250	0.563	1.50
80TL2	2517	4.250	4.125	1.750	0.563	2.70
80TL3	3020	5.250	5.000	2.000	0.563	4.30
100TL1	2517	4.500	4.125	1.750	0.688	2.70
100TL2	3020	5.250	5.000	2.000	0.688	4.30
120TL1	2517	4.250	4.000	1.750	0.875	2.60
120TL2	3020	5.250	5.000	2.000	0.875	4.20
120TL3	3535	6.500	6.500 *	3.500	-	13.00
140TL1	4040	7.750	7.750 *	4.000	-	25.00
160TL1	3020	5.250	5.000	2.000	1.125	4.00
160TL2	3535	6.500	6.250	3.500	1.125	12.60
160TL3	4545	8.750	8.750 *	4.500	-	42.00

\* These items have no step on the hubs.

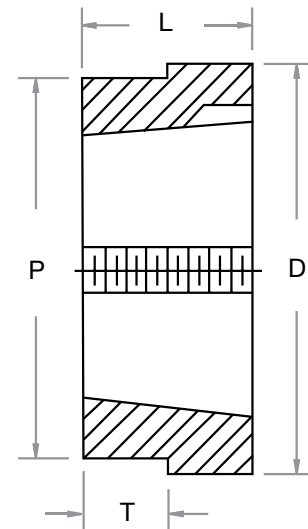

# TAPER-LOCK® WELD-ON HUBS

## TAPER-LOCK® TYPE W WELD-ON HUBS

TAPER-LOCK® type W weld-on hubs are designed for use in applications such as welding to plate sprockets, pulleys, and agitators. Each is made of steel, drilled, tapped, and taper bored for TAPER-LOCK® bushings. The W-series Weld-On Hubs are generally used for severe duty applications.

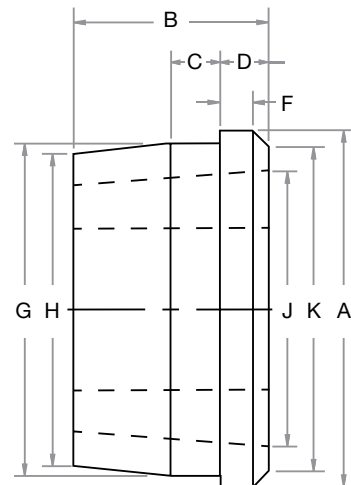

All dimensions in inches unless noted.

Hub Number	Use with Bushing #	A	B	C	D	F	G	H	J	K	Wt. Lbs
W12	1215	2.875	1.500	0.375	0.625	0.375	2.500	2.375	1.875	2.625	1.30
W16	1615	3.250	1.500	0.375	0.625	0.375	2.875	2.750	2.375	3.000	1.50
W25	2517	4.875	1.750	0.500	0.750	0.375	4.375	4.250	3.375	4.625	4.00
W30	3030	5.500	3.000	0.750	0.750	0.250	5.125	4.813	4.125	5.000	8.60
W35	3535	6.750	3.500	1.250	1.000	0.375	6.250	5.938	5.000	6.000	15.00
W40	4040	7.750	4.000	1.500	1.000	0.375	7.250	6.875	5.750	7.000	29.00
W45	4545	8.750	4.500	1.750	1.000	0.375	8.000	7.625	6.375	8.000	42.00





## QD® BUSHINGS

How to Order Code: Example Model # for QD® Bushings

<b>A</b>	<b>SDS</b>	<b>-1B</b>
----------	------------	------------

Altered <sup>!!</sup>	QD® Bushing	Bore Size			
A: Alteration Required	JA	Blank = stock plain bore			
	SH	H	1/2"	(0.500")	
	SDS	I	9/16"	(0.563")	
	SDS	J	5/8"	(0.625")	
	SK	K	11/16"	(0.688")	
	SF	L	3/4"	(0.750")	
	E	M	13/16"	(0.813")	
	F	P	7/8"	(0.875")	
	J	R	15/16"	(0.938")	
	M	1	1"	(1.000")	
	N	1A	1-1/16"	(1.063")	
	P	1B	1-1/8"	(1.125")	

Above are examples. There are more sizes available. Please see QD® Bushing selection chart on pages 172 and 173.

<sup>!!</sup>Alteration field only to be denoted if a deviation from standard is required. Please reference Alterations in engineering section, page 182.

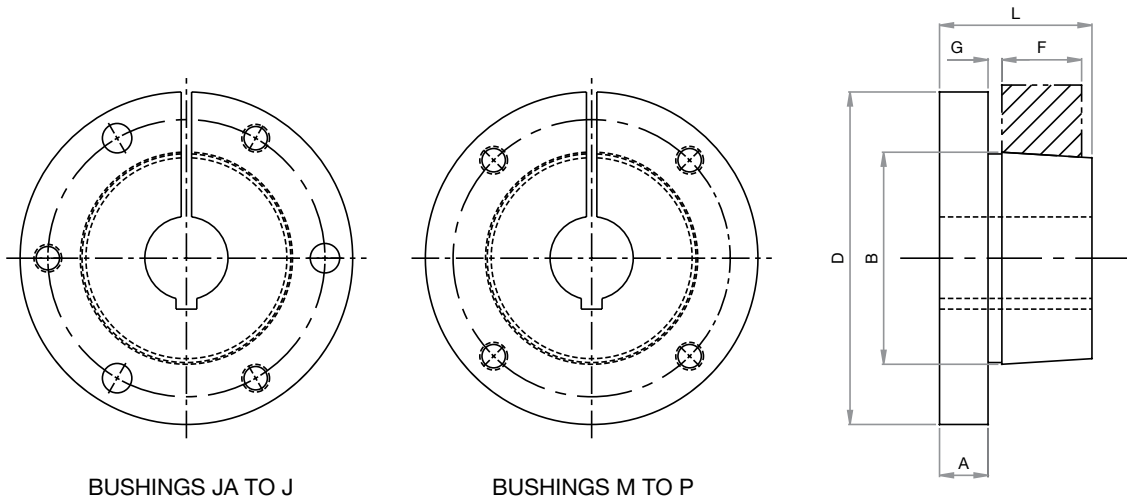

# QD® BUSHINGS

## QD® Bushing Dimensional Information

All dimensions in inches unless noted.

QD® Bushing	Bore Range				Torque Capacity (lb-in)	A	B	D	F	G	L	Wt. Lbs
	Min.	Max w/ Standard Keyway	Max w/ Shallow Keyway	Max w/No Keyway								
JA	0.500	1.000	1.188	1.250	1,000	0.375	1.375	2.000	0.563	0.125	1.063	0.80
SH	0.500	1.375	1.625	1.688	3,500	0.438	1.871	2.625	0.813	0.125	1.313	0.70
SDS	0.500	1.625	1.938	2.000	5,000	0.438	2.187	3.188	0.760	0.125	1.313	1.00
SD	0.500	1.625	1.938	2.000	5,000	0.438	2.187	3.188	1.250	0.125	1.813	1.20
SK	0.500	2.125	2.500	2.625	7,000	0.563	2.812	3.875	1.250	0.125	1.938	2.10
SF	0.500	2.313	2.938	2.938	11,000	0.625	3.125	4.625	1.250	0.125	2.063	3.10
E	0.875	2.875	3.500	-	20,000	0.873	3.834	6.000	1.625	0.250	2.750	7.10
F	1.000	3.250	3.938	4.000	30,000	0.938	4.437	6.625	2.500	0.344	3.750	8.70
J	1.500	3.750	4.500	-	45,000	1.125	5.148	7.250	3.188	0.375	4.625	16.80
M	2.000	4.750	5.500	-	85,000	1.250	6.500	9.000	5.188	0.400	6.750	56.00
N	2.438	5.000	6.000	-	150,000	1.500	7.000	10.000	6.250	0.563	8.125	68.00
P	2.938	5.938	7.000	-	250,000	1.750	8.250	11.750	7.250	0.625	9.375	120.00

All dimensions in inches unless noted.

QD® Bushing	Cap Screws			Bolt Torque (FT. LBS.)
	Size	Quantity Req.	Bolt Circle*	
JA	10 - 24 x 1	3	1.656	5
SH	1/4 x 1 3/8	3	2.250	9
SDS	1/4 x 1 3/8	3	2.688	9
SD	1/4 x 1 7/8	3	2.688	9
SK	5/16 x 2	3	3.313	15
SF	3/8 x 2	3	3.875	30
E	1/2 x 2 3/4	3	5.000	60
F	9/16 x 3 5/8	3	5.625	75
J	5/8 x 4 1/2	3	6.250	135
M	3/4 x 6 3/4	4	7.875	225
N	7/8 x 8	4	8.500	300
P	1 x 9 1/2	4	10.000	450

# QD® BUSHING SELECTION CHART

QD® Bushing													
Bore Size in Inches	Item Code	JA	SH	SDS	SD	SK	SF	E	F	J	M	N	P
1/2"	H	.	.	.	.	.	.						
9/16"	I	.	.	.	.	.	.						
5/8"	J	.	.	.	.	.	.						
11/16"	K	.	.	.	.	.	.						
3/4"	L	.	.	.	.	.	.						
13/16"	M	.	.	.	.	.	.						
7/8"	P	.	.	.	.	.	.	.					
15/16"	R	.	.	.	.	.	.	.					
1"	1	.	.	.	.	.	.	.	.				
1-1/16"	1A	S	.	.	.	.	.	.	.				
1-1/8"	1B	S	.	.	.	.	.	.	.				
1-3/16"	1C	S	.	.	.	.	.	.	.				
1-1/4"	1D	N	.	.	.	.	.	.	.				
1-5/16"	1E		.	.	.	.	.	.	.				
1-3/8"	1F		.	.	.	.	.	.	.				
1-7/16"	1G		S	.	.	.	.	.	.				
1-1/2"	1H		S	.	.	.	.	.	.	.			
1-9/16"	1I		S	.	.	.	.	.	.	.			
1-5/8"	1J		S	.	.	.	.	.	.	.			
1-11/16"	1K		N	S	S	.	.	.	.	.			
1-3/4"	1L			S	S	.	.	.	.	.			
1-13/16"	1M			S	S	.	.	.	.	.			
1-7/8"	1P			S	S	.	.	.	.	.			
1-15/16"	1R			S	S	.	.	.	.	.			
2"	2			N	N	.	.	.	.	.	.		
2-1/16"	2A					.	.	.	.	.	.		
2-1/8"	2B					.	.	.	.	.	.		
2-3/16"	2C					S	.	.	.	.	.		
2-1/4"	2D					S	.	.	.	.	.		
2-5/16"	2E					S	.	.	.	.	.		
2-3/8"	2F					S	S	.	.	.	.		
2-7/16"	2G					S	S	.	.	.	.	.	
2-1/2"	2H					S	S	.	.	.	.	.	
2-9/16"	2I					N	S	.	.	.	.	.	
2-5/8"	2J					N	S	.	.	.	.	.	
2-11/16"	2K						S	.	.	.	.	.	
2-3/4"	2L						S	.	.	.	.	.	
2-13/16"	2M						S	.	.	.	.	.	
2-7/8"	2P						S	.	.	.	.	.	
2-15/16"	2R						S	S	.	.	.	.	
3"	3							S	.	.	.	.	
3-1/16"	3A							S	.	.	.	.	
3-1/8"	3B							S	.	.	.	.	
3-3/16"	3C							S	.	.	.	.	
3-1/4"	3D							S	.	.	.	.	
3-5/16"	3E							S	.	.	.	.	
3-3/8"	3F							S	S	.	.	.	
3-7/16"	3G							S	S	.	.	.	.
3-1/2"	3H							S	S	.	.	.	.
3-9/16"	3I								S	.	.	.	.
3-5/8"	3J								S	.	.	.	.
3-11/16"	3K								S	.	.	.	.
3-3/4"	3L								S	.	.	.	.

See page 195 for Shallow keyway dimensions.

S = Shallow keyway in hub

N = No keyway in hub

# QD® BUSHING SELECTION CHART

QD® Bushing													
Bore Size in Inches	Item Code	JA	SH	SDS	SD	SK	SF	E	F	J	M	N	P
3-13/16"	3M								S	•	•	•	•
3-7/8"	3P								S	S	•	•	•
3-15/16"	3R								S	S	•	•	•
4"	4								N	S	•	•	•
4-1/16"	4A									S	•	•	•
4-1/8"	4B									S	•	•	•
4-3/16"	4C									S	•	•	•
4-1/4"	4D									S	•	•	•
4-5/16"	4E									S	•	•	•
4-3/8"	4F									S	•	•	•
4-7/16"	4G									S	•	•	•
4-1/2"	4H									S	•	•	•
4-9/16"	4I										•	•	•
4-5/8"	4J										•	•	•
4-11/16"	4K										•	•	•
4-3/4"	4L										•	•	•
4-13/16"	4M										•	•	•
4-7/8"	4P										S	•	•
4-15/16"	4R										S	•	•
5"	5										S	•	•
5-1/16"	5A										S	•	•
5-1/8"	5B										S	S	•
5-3/16"	5C										S	S	•
5-1/4"	5D										S	S	•
5-5/16"	5E										S	S	•
5-3/8"	5F										S	S	•
5-7/16"	5G										S	S	•
5-1/2"	5H										S	S	•
5-9/16"	5I											S	•
5-5/8"	5J											S	•
5-11/16"	5K											S	•
5-3/4"	5L											S	•
5-13/16"	5M											S	•
5-7/8"	5											S	•
5-15/16"	5R											S	•
6"	6											S	S
6-1/16"	6A												S
6-1/8"	6B												S
6-3/16"	6C												S
6-1/4"	6D												S
6-5/16"	6E												S
6-3/8"	6F												S
6-7/16"	6G												S
6-1/2"	6H												S
6-9/16"	6I												S
6-5/8"	6J												S
6-11/16"	6K												S
6-3/4"	6L												S
6-13/16"	6M												S
6-7/8"	6P												S
6-15/16"	6R												S
7"	7												S

See page 195 for Shallow keyway dimensions.

S = Shallow keyway in hub

N = No keyway in hub

# QD® WELD-ON HUBS

Tsubaki offers the most complete line of “QD®” Style weld-on hubs for insertion and welding to produce “B” style sprockets, sheaves, and other applications. To provide greater strength for this type of shaft locking mechanism and reduce heat distortion caused by welding, these hubs are dimensionally the same as our sprocket items. Special dimensional hubs are available per your specifications on a made-to-order basis. All Tsubaki hubs are made from steel bar stock (not powdered or sintered metal). The “QD®” Style Weld-On hubs listed below include appropriate tapered bores and mounting holes. QD® Weld-On hubs are manufactured with a step for assistance in locating the attached plate. This is shown as the “T” dimension and depending on the width of the plate, the result is either a B-style or C-style sprocket.

All dimensions in inches unless noted.

Catalog Number	Use with Bushing #	Dim. D	Dim. P	Dim. L	Dim. T	Hub Type	Wt. Lbs.
35SHW	SH	3.00	2.875	0.813	0.141	B	.90
40SDSW	SDS	3.500	3.125	0.750	0.250	B	1.00
40SKW	SK	4.250	3.875	1.250	0.250	B	2.40
50SDSW	SDS	3.625	3.438	0.750	0.313	B	1.00
50SKW	SK	4.250	4.125	1.250	0.313	B	2.40
50SFW	SF	5.000	4.625	1.250	0.313	B	3.70
60SDSW	SDS	3.500	3.125	0.750	0.438	B	1.00
60SKW	SK	4.250	3.875	1.250	0.438	B	2.40
60SFW	SF	5.000	4.625	1.250	0.438	B	3.60
60EW	E	6.250	5.875	1.625	0.438	B	7.80
80SFW	SF	5.000	4.625	1.250	0.563	B	3.50
80EW	E	6.250	5.875	1.625	0.563	C	7.70
80FW	F	7.000	6.625	2.500	0.563	C	14.70
100EWB	E	6.250	5.875	1.625	0.688	B	7.50
100EWC	E	6.250	5.875	1.625	0.688	C	7.50
100FW	F	7.000	6.625	2.500	0.688	C	14.60
120EW	E	6.250	5.875	1.625	0.875	B	7.40
120FW	F	7.000	6.625	2.500	0.875	C	14.30
120JW	J	8.000	7.500	3.188	0.875	C	23.70
160FW	F	7.000	6.625	2.500	1.094	B	14.00
160JW	J	8.000	7.500	3.188	1.125	C	23.30
160MW	M	10.000	9.500	5.188	2.250	C1	59.30

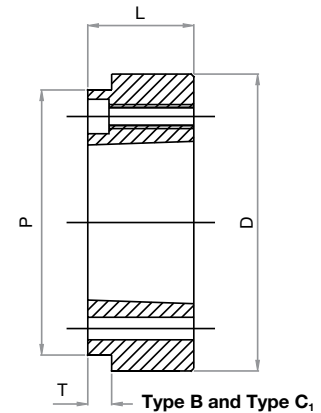
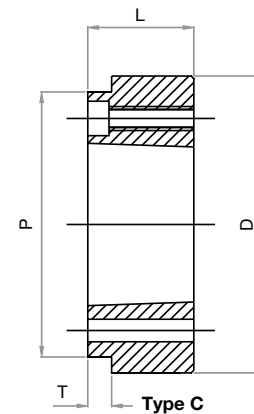



# IDLER SPROCKETS

Adjustable Idler Sprockets are used to:

- Obtain proper chain tension when either driving or driven shaft is not adjustable.
- Guide chain around an obstruction.
- Prevent whipping action in the slack span of chain.
- Bring about greater chain wrap around a small sprocket, particularly if it is the lower sprocket in a vertical drive.
- Take up slack chain caused by normal chain wear.
- Provide for reversed direction of rotation of a sprocket in contact with the outside of the chain.

Idler sprockets should not rotate at greater speeds than are allowable for drive sprockets of the same diameter. They should be mounted in contact with the “slack” span of chain, whenever possible. Mount them on the outside of the chain when the arc of chain wrap on the smaller sprocket would otherwise be less than  $120^\circ$ . It is advisable that idler sprockets have at least three teeth in mesh with the chain. Inside mounted idlers usually account for quieter operation, especially if sprocket to sprocket centers are short and speed is moderately high.

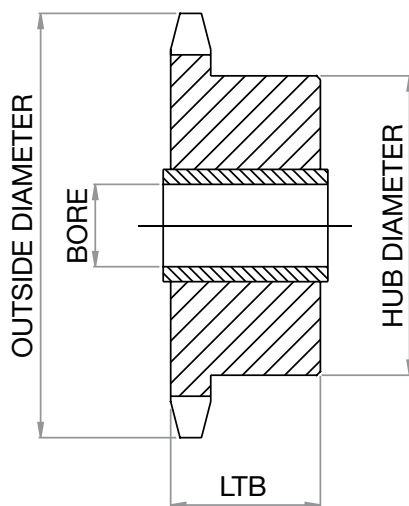

Bronze Bushed Idler

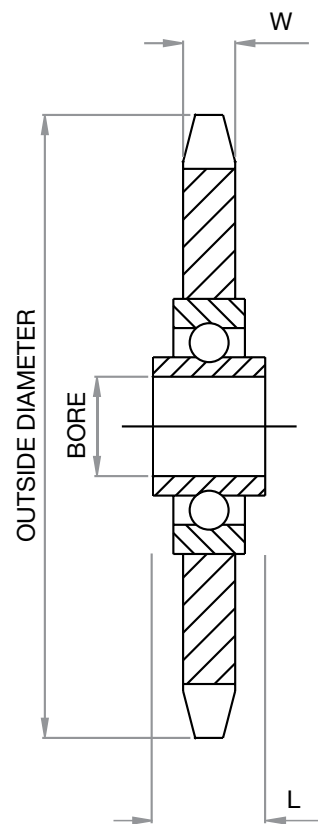

Ball Bearing Idler



## IDLER SPROCKETS-BRONZE BUSHED TYPE

How to Order Code:

Example Model # for Bronze Bushed Idler Sprockets for use with all steel chain

<b>35</b>	<b>B</b>	<b>15T</b>
Roller Chain Pitch Size	Hub Type	Number of Teeth
35: 3/8" Pitch (example pitch size)	B: Hub Extension One Side	15T: 15 Teeth

### Bronze Bushed Idler Sprocket with Hardened Teeth

Note: Bronze Idler Sprockets should not exceed 2500-rpm and have a radial loading of 50 lbs. or less.

All dimensions in inches unless noted.

ANSI Chain #	Sprocket #	# of Teeth	Suggested Tensioner #*	Outside Diameter	HUB Type	Hub Diameter	LTB	Bushed Bore Dia.	Wt. Lbs.
35	35B15T	15	0	1.990	B	1.375	0.938	0.500	0.32
35	35B21T	21	1	2.713	B	2.125	1.063	0.875	0.82
40	40B13T	13	0	2.329	B	1.563	0.938	0.500	0.52
40	40B19T	19	1	3.296	B	2.438	1.063	0.875	1.50
41	41B13T	13	0	2.329	B	1.563	0.938	0.500	0.52
41	41B19T	19	1	3.296	B	2.438	1.063	0.875	1.30
50	50B13T	13	0	2.911	B	2.000	0.938	0.500	0.97
50	50B17T	17	1	3.719	B	2.625	1.063	0.875	1.80
60	60B15T	15	1	3.979	B	2.688	1.063	0.875	2.50
60	60B17T	17	2	4.462	B	2.875	1.563	1.125	3.30
80	80B15T	15	2	5.305	B	3.500	1.563	1.125	5.60
100	100B13T	13	2	5.821	B	4.000	1.563	1.125	5.70
120	120B13T	13	2	6.986	B	4.500	1.563	1.125	13.00
140	140B15T	15	3	9.283	B	5.750	2.500	1.750	27.30
160	160B13T	13	3	9.318	B	5.750	2.500	1.750	26.40
200	200B13T	13	3	11.642	B	5.750	2.500	1.750	58.00

\*Please reference page 179 for chain tensioner information.

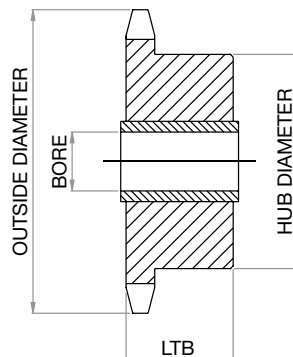

Bronze Bushed Idler





# IDLER SPROCKETS - BALL BEARING TYPE

How to Order Code: Example Model # for Ball Bearing Idler Sprockets

<b>35</b>	<b>BB</b>	<b>20H</b>
Roller Chain Pitch Size	Idler Type	Number of Teeth
35: 3/8" Pitch (example pitch size)	BB: Ball Bearing Idler	20H: 20 Teeth - Hardened

### Ball Bearing Idler Sprocket with Hardened Teeth

All dimensions in inches unless noted.

ANSI Chain #	Sprocket #	# of Teeth	Outside Diameter	HUB Type	Nominal Tooth Width (W)	LTB	Bore Dia.	Wt. Lbs.
35	35BB20H	20	2.600	C	0.168	0.720	0.638	0.38
40	40BB17H	17	2.970	C	0.284	0.720	0.638	0.52
40	40BB18H	18	3.140	C	0.284	0.720	0.638	0.53
50	50BB15H	15	3.320	C	0.343	0.720	0.638	0.75
50	50BB17H	17	3.720	C	0.343	0.720	0.638	0.78
60	60BB13H	13	3.510	C	0.459	0.720	0.638	0.76
60	60BB15H	15	3.980	C	0.459	0.720	0.638	1.06
80	80BB12H	12	4.360	C	0.575	0.610	0.750	1.50

Note: Bore tolerance for 35BB20H - 60BB15H is 0.638" - 0.643".  
 These often utilize a 5/8" bolt to secure.  
 Bore tolerance for 80BB12H is 0.750" - 0.755".  
 This size will often use a 3/4" bolt to secure.

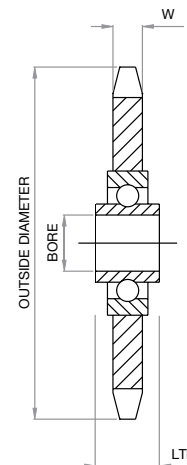

### Ball Bearing Idler Sprocket Radial Load Capacity in Pounds

Description	R.P.M.															
	50	100	300	500	750	1000	1200	1500	1800	2400	2600	3000	3600	4000	4500	5000
35BB20H-60BB13H	650	515	357	300	265	240	225	208	195	179	173	155	156	151	143	140
80BB12H	1630	1290	895	755	665	600	565	523	493	447	434	415	-	-	-	-

Ratings shown above are based on an average bearing life of 2500 hours.

# CHAIN TENSIONER - MANUAL TYPE

Proper chain tension is necessary to obtain acceptable chain life. Tensioners are designed to adjust the slack that is needed and develops as chains operate on a daily basis. Tensioners contribute to efficient, quiet operation of the drive assembly.

## Selection Code:

Suggested Chain Size	Manual Tensioner Model #
35	0-B
40, 41	0-B or 1-B
50	1-B
60	1-B
80	2-B
100	2-B
120	2-B
140	3-B
160	3-B
200	3-B

## Manual Tensioner

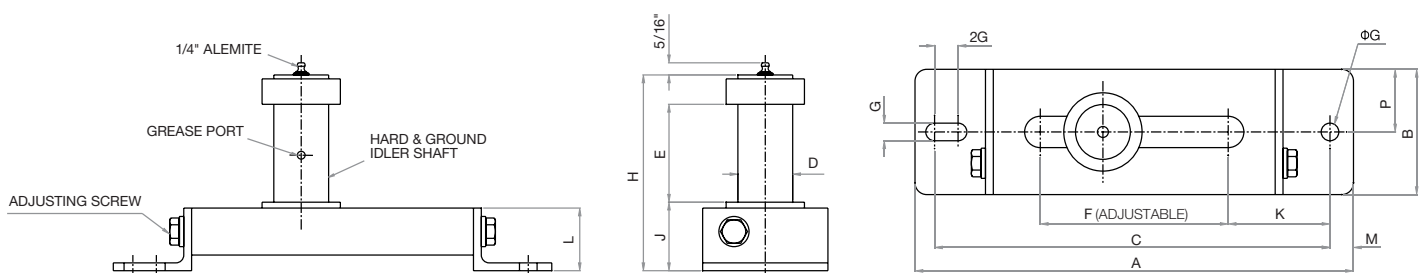

All dimensions in inches unless noted.

Model Number	A	B	C	D	E	F	G	2G	H	J	K	L	M	P	Wt. Lbs.
0-B	5.875	1.500	5.250	0.500	1.000	2.500	0.281	0.375	2.813	1.313	1.375	1.250	0.375	0.750	1.00
1-B	9.000	2.000	8.125	0.875	1.750	4.500	0.344	0.500	4.000	1.625	1.750	1.500	0.500	1.000	2.50
2-B	13.000	3.000	11.875	1.125	1.875	6.000	0.563	0.750	5.688	2.156	2.875	2.000	0.625	1.500	6.00
3-B	14.000	4.000	12.625	1.750	3.125	6.000	0.563	0.750	6.250	2.188	3.250	2.000	0.750	2.000	12.00

# CHAIN TENSIONER - AUTOMATIC TYPE

MAXTON series automated chain tensioners

- \* Automatic tensioning
- \* Stable vibration dampening
- \* Operates on return side in any position
- \* Simple adjusting
- \* Quick and easy installation

## AUTOMATIC TENSIONER

All dimensions in millimeters unless noted.

Chain Size	Automated Model Number	Stroke (S)	Push-up Force (lbs.)	
			Min.	Max
35	TH1	25.0	8.81	26.44
40, 41	TH1	25.0	8.81	26.44
50	TH2	45.0	22.03	66.10
60	TH2	45.0	22.03	66.10
80	TH2	45.0	22.03	66.10

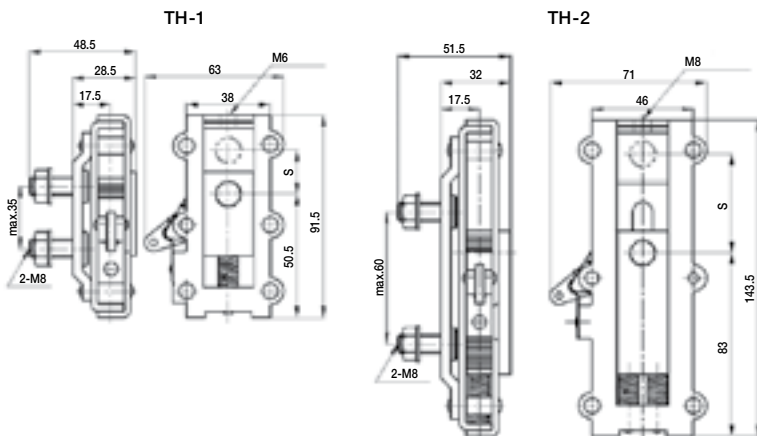

Adapter (Note: S1 and S2 adapter work with both Tensioner TH1 and TH2)

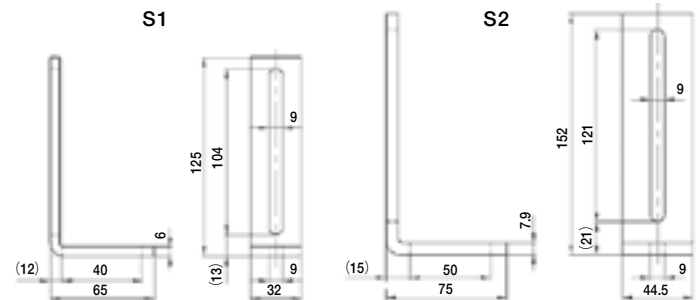

## IDLER SPROCKETS FOR AUTOMATIC TENSIONER

Chain Size	No. of Teeth	Pitch Diameter (in inches)	Model No.	
			Sintered Bushing ID	Ball Bearing ID
35	20	2.397	SP-320-OB	SP-320-BB
40,41	15	2.405	SP-415-OB	SP-415-BB
50	15	3.006	SP-515-OB	SP-515-BB
60	14	3.371	SP-604-OB	SP-604-BB
80	11	3.550	-	SP-811-BB

Idler Sprocket

BB Type

OB Type

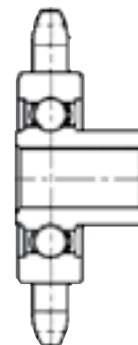



# ENGINEERING DATA

<b>Engineering Data</b>	<b>181</b>
Alterations	182 - 185
Sprocket Hardening	186
Sprocket Tooth Dimensions	187
Sprocket Pitch Diameter Constants	188
Sprocket Speed Ratios	189
Sprocket Diameters	190 - 192
Standard Keyway and Set Screws	193
TAPER-LOCK® Shallow Keyway Dimensions	194
QD® Shallow Keyway Dimensions	195
Maintenance Checklist	196
Safety Warning	197
Other Sprocket Considerations	198 - 199
Terms and Conditions of Sale	200

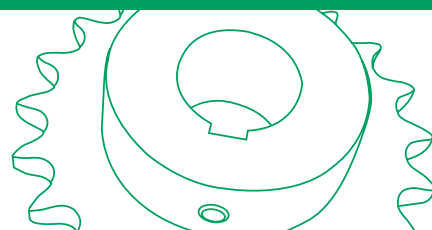

# ALTERATIONS

The term “alteration” applies to a modification/change in configuration from standard for a stock sprocket. All Tsubaki sprockets can be “Altered” to meet select application requirements. The following provides a list of common alterations performed by Tsubaki to stock sprockets, and an explanation of what each is. In the event that the modification requested is not listed, it does not mean that the sprocket cannot be altered. However, it may mean that the alteration in question would require the sprocket be Made-To-Order (MTO) to meet the application requirements at hand. Please consult a Tsubaki Customer Service Representative to review additional options available for altered and MTO sprockets.

## Sprocket Reboring

Reboring is a process of changing the dimension or configuration of the sprocket inner hub diameter to meet the application requirements at hand. Typical reboring alterations include:

- Hub inside diameter dimension not listed as standard
- Hub inside diameter dimension greater than standard
- Hub inside diameter dimension smaller than standard
- Metric inside hub diameter dimension
- Hexagon broached inside diameter hub configuration
- Splined broached inside diameter hub configuration
- Change to Length Through Bore (LTB) dimension

Please reference **Figure 1** for an illustration of a typical finished bore sprocket.

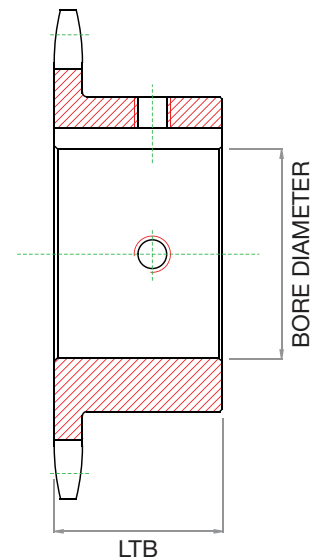

**Figure 1** - Typical finished bore sprocket

## Sprocket Keyway & Set Screw

Tsubaki standard keyway configuration facilitates use of industry standard square key stock in inch sizes with use of common set screws. The standard keyway location is center line of tooth  $\pm 0.015$ ". Two set screws are furnished with finished bore sprockets. One set screw is placed directly over the keyway. The second set screw is placed at 90 degrees from the keyway set screw. Application requirements may demand a different keyway and set screw configuration than standard. Common alterations to standard keyway / set screw configurations include:

- Keyway non center line of tooth
- Tapered keyway
- Multiple keyways
- Metric keyway
- Metric set screws
- Set screw location other than standard

Please see **Figure 2** for standard keyway locations.

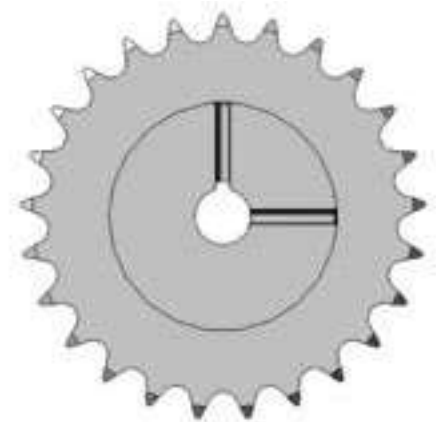
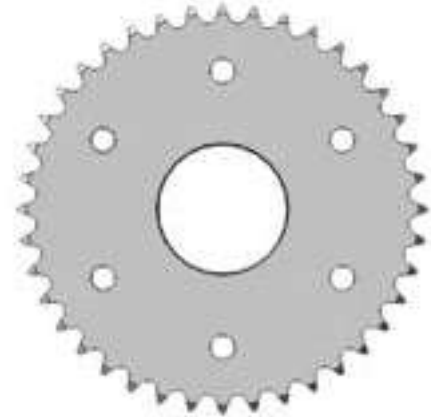

**Figure 2** - Standard Keyway and set screw location

# ALTERATIONS

## Sprocket Hub Mounting Holes

Tsubaki stock sprockets do not come with bolt mounting holes with the exception of Taper-Lock® and QD® hubs. In select instances, bolt mounting holes may be required in order to facilitate attachment of custom hubs, or accessory pieces that may be required to fulfill the needs of the application at hand. Sprocket bolt mounting holes typically apply to “A” plate sprocket types, where the holes required are located around the circumference of the plate bore. However, select “B” style sprockets may also require mounting holes. Please reference [Figure 3](#) for a depiction of an “A” plate sprocket with mounting holes installed.



*Figure 3 - “A” plate sprocket with mounting holes*

## Sprocket Lightening Holes

There may be instances where reducing the weight of a given sprocket would be advantageous for the application. This is more common for applications that utilize large pitch sprockets. Tsubaki offers the option to incorporate lightening holes into sprockets at an additional charge. Please reference [Figure 4](#) for a depiction of an “A” plate sprocket with lightening holes.

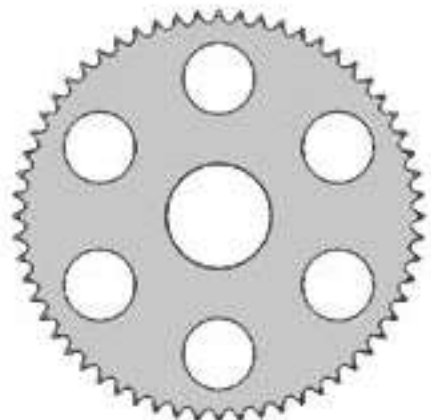

*Figure 4 - “A” plate sprocket with lightening holes*

## Sprocket Hub Outside Diameter

Select applications may call for the sprocket hub diameter to be reduced in size or increased for various reasons. Tsubaki offers the option to reduce the outside diameter of a given hub by removing material. Please reference [Figure 5](#) for a depiction of a “B” style sprocket with a smaller hub diameter versus standard. Larger diameter hubs may be more difficult to accommodate but please contact Tsubaki if needed.



*Figure 5 - Reduced hub diameter*

## Tapered Hub Bore/Tapered Keyway

Tsubaki offers the option to taper the inside bore diameter or keyway for all “B” style stock sprockets. Please reference [Figure 6](#) for a depiction of a tapered bore “B” style sprocket.

# ALTERATIONS

## Snap Ring Grooves

Tsubaki offers the option of implementing snap ring grooves on all stock “B” and “C” style sprockets. The snap ring and groove can be used in conjunction to position the sprocket or to limit movement along the shaft. Please reference [Figure 7](#) for a depiction of snap ring grooves installed on a “B” style sprocket.

## Slotted Plates

Tsubaki offers the option to implement slots into the sprocket plate. Similar to lightening holes, slotted plates reduce weight or may be used along with mounting bolts to adjust the sprocket timing. Please reference [Figure 8](#) for a depiction of a slotted “B” style sprocket.

## Split Sprockets

Steel split sprockets offer ease of installation and removal for applications that require the sprocket be changed frequently or quickly. Tsubaki offers the option of cutting and providing the steel split hub as an assembly or package to suit your needs. Please reference [Figure 9](#) for a depiction of a steel split sprocket assembly.



**Figure 6** - Tapered bore “B” style sprocket

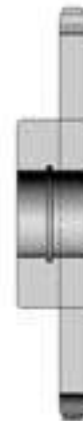

**Figure 7** - “B” style sprocket with snap ring groove



**Figure 8** - Slotted “B” style sprocket

# ALTERATIONS

## Sprocket Plating/Coating

Tsubaki offers special plating/coating options on all stock sprockets. Plating options include: Zinc, Electroless Nickel, Cadmium, and other common industry coatings to increase corrosion resistance. Please reference [Figure 10](#) for a depiction of a cadmium plated sprocket.



*Figure 9 - Steel split sprocket*

## Sprocket Coating Removal

(stripped sprockets)

All Tsubaki stock carbon steel sprockets are black oxide coated for corrosion resistance from the factory. Select end-users may opt to paint or anodize the sprocket themselves. Tsubaki does offer the option to have the black oxide coating removed per customer request.



*Figure 10 - Cadmium plated "B" style sprocket*

## Segmental Rim Sprockets

Segmental Rim Sprockets are designed to save time and money. They eliminate costly downtime during installation and adjustment. The segmental rim is bolted to a solid or split body. That means bodies or entire sprockets may be replaced without removing shaft or bearings, saving maintenance time and money. Please refer to [Figure 11](#) for an illustration.

### NOTES:

---

---

---

---

---

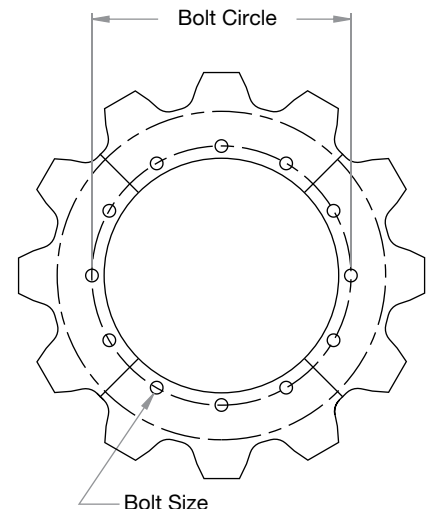

*Figure 11 - Segmental rim sprocket*



# SPROCKET HARDENING

Hardness Conversion Table

Rockwell "C" 150 KG. Load	A 60 KG.	Shore Model C	Brinell No.	Tensile Str. Lbs. per Sq. In.
			3000 KG. Load	
10		27	183	91,000
11		28	187	93,000
13		28	192	95,000
14		29	197	97,000
15		30	202	99,000
16		30	207	101,000
17		31	212	104,000
18		31	217	107,000
20	60.5	32	223	110,000
21	61.0	33	229	113,000
22	61.5	34	235	116,000
23	62.0	35	241	119,000
24	62.5	36	248	122,000
25	63.0	37	255	125,000
26	63.5	37	262	128,000
28	64.5	38	269	131,000
29	65.0	39	277	134,000
30	65.5	40	285	138,000
31	66.0	42	293	142,000
32	66.5	43	302	146,000
33	67.0	44	311	150,000
34	67.5	45	321	155,000
35	68.0	46	331	160,000
36	68.5	48	341	165,000
37	69.0	49	352	170,000
38	69.5	51	363	176,000
40	70.5	52	375	182,000
41	71.0	54	388	189,000
42	71.5	55	401	196,000
44	72.5	57	415	204,000
45	73.0	59	429	212,000
46	73.5	61	444	220,000
47	74.0	63	461	229,000
49	75.5	65	477	238,000
50	76.0	67	495	247,000
52	77.0	70	514	256,000
53	77.5	72	534	266,000
55	78.5	75	555	276,000
57	79.5	78	578	287,000
58	80.0	81	601	298,000
60	81.0	84	627	311,000
62	82.5	87	653	324,000
64	83.5	91	682	337,000
66	84.5	95	712	352,000
68	85.5	100	745	368,000
70	86.5	106	780	384,000

All Tsubaki sprockets are made using high quality 1045 steel. Since chain loadings are evenly distributed over all engaged sprocket teeth, tooth breakage or distortion is not normally a problem. It is seldom necessary to use special high-strength material.

The hardening process of small diameter, small pitch sprockets is usually a one-step procedure; heat treatment through electrical induction. Large diameter, large pitch sprockets can usually be directly flame hardened. These methods are used to provide a high hardness at the wear areas, plus provide the ability of the tooth to absorb shock loads. This is accomplished by hardening only the wear area of each tooth while maintaining a ductile tooth core which is tough and resilient. The hubs and bores remain soft to permit reworking.

The general guidelines for stock sprockets are:

Size	Rockwell Scales	
	A	C
35-80 Pitch	68-76	35-50
100-240 Pitch	63-70	25-40



**Thru Hardened Teeth**

*Case hardened on wear surfaces  
with tough resilient core*

# SPROCKET TOOTH DIMENSIONS

## Sprocket Tooth Dimensions — Standard

All dimensions are in inches unless otherwise indicated.

Chain Data for All Sprockets				Single Strand $t_1$	Double and Triple Strand			For 4 or more Strands							Machining Tolerance on " $t$ " and " $M$ "
ANSI	Pitch P	Roller Width W	Roller Diam.		$t_2$	$M_2$	$M_3$	$t_4$	$M_2$	$M_3$	$M_4$	$M_5$	$M_6$	$M_8$	

### STANDARD SERIES CHAIN SPROCKETS

25	1/4	1/8	.130	.110	.107	.359	.611	.096	.348	.600	.852	1.140	1.356	1.860	.252	-.007
35	3/8	3/16	.200	.168	.162	.561	.960	.149	.548	.947	1.346	1.745	2.144	2.942	.399	-.008
40	1/2	5/16	.312	.284	.275	.841	1.407	.256	.822	1.388	1.954	2.520	3.086	4.218	.566	-.009
50	5/8	3/8	.400	.343	.332	1.045	1.758	.311	1.024	1.737	2.450	3.163	3.876	5.302	.713	-.010
60	3/4	1/2	.469	.459	.444	1.341	2.238	.418	1.315	2.212	3.109	4.006	4.903	6.697	.897	-.011
80	1	5/8	.625	.575	.557	1.710	2.863	.526	1.679	2.832	3.985	5.138	6.291	8.597	1.153	-.012
100	1 1/4	3/4	.750	.692	.669	2.077	3.485	.633	2.041	3.449	4.857	6.265	7.673	10.489	1.408	-.014
120	1 1/2	1	.875	.924	.894	2.683	4.472	.848	2.637	4.426	6.215	8.004	9.793	13.371	1.789	-.016
140	1 3/4	1	1.000	.924	.894	2.818	4.742	.848	2.772	4.696	6.620	8.544	10.468	14.316	1.924	-.016
160	2	1 1/4	1.125	1.156	1.119	3.424	5.729	1.063	3.368	5.673	7.978	10.283	12.588	17.198	2.305	-.019
180	2 1/4	1 13/32	1.406	1.301	1.259	3.851	6.443	1.197	3.789	6.381	8.973	11.565	14.157	19.341	2.592	-.020
200	2 1/2	1 1/2	1.562	1.389	1.344	4.161	6.978	1.278	4.095	6.912	9.729	12.546	15.363	20.997	2.817	-.021
240	3	1 7/8	1.875	1.738	1.682	5.140	8.598	1.601	5.059	8.517	11.975	15.433	18.891	—	3.458	-.025

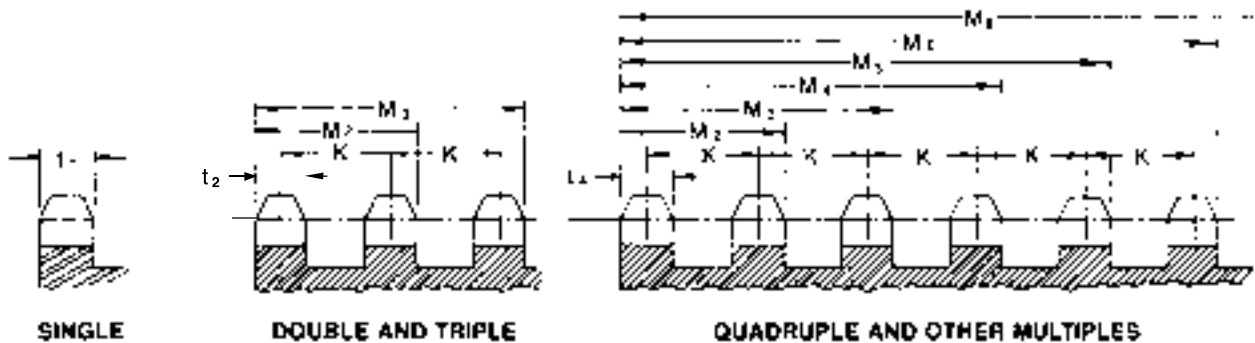

# SPROCKET PITCH DIAMETER CONSTANTS

All dimensions are in inches unless otherwise indicated.

Number of Teeth	Constant	Number of Teeth	Constant	Number of Teeth	Constant
4	1.4142	53	16.8803	102	32.473
5	1.7013	54	17.1984	103	32.791
6	2.0000	55	17.5166	104	33.109
7	2.3048	56	17.8347	105	33.427
8	2.6131	57	18.1529	106	33.746
9	2.9238	58	18.4710	107	34.064
10	3.2361	59	18.7892	108	34.382
11	3.5495	60	19.1073	109	34.701
12	3.8637	61	19.4255	110	35.019
13	4.1785	62	19.7437	111	35.337
14	4.4940	63	20.0618	112	35.655
15	4.8097	64	20.3800	113	35.974
16	5.1259	65	20.6982	114	36.292
17	5.4423	66	21.0164	115	36.610
18	5.7588	67	21.3346	116	36.929
19	6.0756	68	21.6528	117	37.247
20	6.3925	69	21.9710	118	37.565
21	6.7095	70	22.2892	119	37.883
22	7.0266	71	22.6074	120	38.201
23	7.3439	72	22.9256	121	38.519
24	7.6613	73	23.2438	122	38.837
25	7.9787	74	23.5620	123	39.156
26	8.2962	75	23.8802	124	39.475
27	8.6138	76	24.1984	125	39.794
28	8.9315	77	24.5166	126	40.112
29	9.2491	78	24.8349	127	40.430
30	9.5668	79	25.1531	128	40.748
31	9.8845	80	25.4713	129	41.066
32	10.2023	81	25.7896	130	41.384
33	10.5201	82	26.1079	131	41.702
34	10.8380	83	26.4261	132	42.020
35	11.1558	84	26.7442	133	42.338
36	11.4737	85	27.0626	134	42.656
37	11.7917	86	27.3807	135	42.975
38	12.1096	87	27.6989	136	43.293
39	12.4275	88	28.0170	137	43.611
40	12.7455	89	28.3355	138	43.930
41	13.0635	90	28.6537	139	44.249
42	13.3815	91	28.9723	140	44.567
43	13.6995	92	29.2901	141	44.885
44	14.0175	93	29.6082	142	45.203
45	14.3356	94	29.9268	143	45.521
46	14.6536	95	30.2447	144	45.840
47	14.9717	96	30.5632	145	46.158
48	15.2898	97	30.8815	146	46.477
49	15.6079	98	31.1999	147	46.796
50	15.9260	99	31.5177	148	47.114
51	16.2441	100	31.8362	149	47.432
52	16.5619	101	32.1540	150	47.750

To obtain the pitch diameter of a sprocket, multiply the constant for the number of teeth (as shown above) by the chain pitch.

To determine the pitch diameter of a 28-tooth sprocket for 140 chain — use a constant of 8.9315 and multiply by chain pitch (1.750") to obtain a pitch diameter of 15.630". IE: 140A28 P.D = 15.629".

# SPEED RATIOS

Speed Ratios for Sprocket Combinations - Formula: Driven Sprocket ÷ Driver Sprocket = Ratio

#ofTeeth: Driven Sprocket	Driver Sprocket Teeth																	
	9	10	11	12	13	14	15	16	17	18	19	20	21	22	23	24	25	26
9	1.00																	
10	1.11	1.00																
11	1.22	1.10	1.00															
12	1.33	1.20	1.09	1.00														
13	1.44	1.30	1.18	1.08	1.00													
14	1.56	1.40	1.27	1.17	1.08	1.00												
15	1.67	1.50	1.36	1.25	1.15	1.07	1.00											
16	1.78	1.60	1.45	1.33	1.23	1.14	1.07	1.00										
17	1.89	1.70	1.55	1.42	1.31	1.21	1.13	1.06	1.00									
18	2.00	1.80	1.64	1.50	1.38	1.29	1.20	1.13	1.06	1.00								
19	2.11	1.90	1.73	1.58	1.46	1.36	1.27	1.19	1.12	1.06	1.00							
20	2.22	2.00	1.82	1.67	1.54	1.43	1.33	1.25	1.18	1.11	1.05	1.00						
21	2.33	2.10	1.91	1.75	1.61	1.50	1.40	1.31	1.23	1.17	1.10	1.05	1.00					
22	2.44	2.20	2.00	1.83	1.69	1.57	1.47	1.38	1.29	1.22	1.16	1.10	1.05	1.00				
23	2.56	2.30	2.09	1.92	1.77	1.64	1.53	1.44	1.35	1.28	1.21	1.15	1.09	1.04	1.00			
24	2.67	2.40	2.18	2.00	1.85	1.71	1.60	1.50	1.41	1.33	1.26	1.20	1.14	1.09	1.04	1.00		
25	2.78	2.50	2.27	2.08	1.92	1.79	1.67	1.56	1.47	1.39	1.32	1.25	1.19	1.14	1.09	1.04	1.00	
26	2.89	2.60	2.36	2.17	2.00	1.86	1.73	1.63	1.53	1.45	1.37	1.30	1.24	1.18	1.13	1.08	1.04	1.00
27	3.00	2.70	2.45	2.25	2.08	1.93	1.80	1.69	1.59	1.50	1.42	1.35	1.29	1.23	1.17	1.12	1.08	1.04
28	3.11	2.80	2.54	2.33	2.15	2.00	1.87	1.75	1.65	1.56	1.47	1.40	1.33	1.27	1.22	1.17	1.12	1.08
29	3.22	2.90	2.64	2.42	2.23	2.07	1.93	1.81	1.71	1.61	1.53	1.45	1.38	1.32	1.26	1.21	1.16	1.12
30	3.33	3.00	2.73	2.50	2.31	2.14	2.00	1.88	1.76	1.67	1.58	1.50	1.43	1.36	1.31	1.25	1.20	1.15
31	3.44	3.10	2.82	2.58	2.38	2.21	2.07	1.94	1.82	1.72	1.63	1.55	1.48	1.41	1.35	1.29	1.24	1.19
32	3.56	3.20	2.91	2.67	2.46	2.28	2.13	2.00	1.88	1.78	1.68	1.60	1.52	1.45	1.39	1.33	1.28	1.23
33	3.67	3.30	3.00	2.75	2.54	2.36	2.20	2.06	1.94	1.83	1.74	1.65	1.57	1.50	1.43	1.38	1.32	1.27
34	3.78	3.40	3.09	2.83	2.62	2.43	2.27	2.13	2.00	1.89	1.79	1.70	1.62	1.55	1.48	1.42	1.36	1.31
35	3.89	3.50	3.18	2.92	2.69	2.50	2.33	2.19	2.06	1.95	1.84	1.75	1.67	1.59	1.52	1.46	1.40	1.34
36	4.00	3.60	3.27	3.00	2.77	2.57	2.40	2.25	2.12	2.00	1.89	1.80	1.71	1.63	1.57	1.50	1.44	1.38
37	4.11	3.70	3.36	3.08	2.85	2.64	2.47	2.31	2.18	2.06	1.95	1.85	1.76	1.68	1.61	1.54	1.48	1.42
38	4.22	3.80	3.45	3.17	2.92	2.71	2.53	2.38	2.24	2.11	2.00	1.90	1.81	1.73	1.65	1.58	1.52	1.46
39	4.33	3.90	3.55	3.25	3.00	2.79	2.60	2.44	2.29	2.17	2.05	1.95	1.86	1.77	1.70	1.63	1.56	1.50
40	4.44	4.00	3.64	3.33	3.08	2.86	2.67	2.50	2.35	2.22	2.10	2.00	1.90	1.82	1.74	1.67	1.60	1.54
41	4.56	4.10	3.73	3.42	3.15	2.93	2.73	2.56	2.41	2.28	2.16	2.05	1.95	1.86	1.78	1.71	1.64	1.58
42	4.67	4.20	3.82	3.50	3.23	3.00	2.80	2.63	2.47	2.34	2.21	2.10	2.00	1.91	1.83	1.75	1.68	1.61
43	4.78	4.30	3.91	3.58	3.31	3.07	2.87	2.69	2.53	2.39	2.26	2.15	2.05	1.95	1.87	1.79	1.72	1.65
44	4.89	4.40	4.00	3.67	3.38	3.14	2.93	2.75	2.59	2.44	2.32	2.20	2.10	2.00	1.91	1.83	1.76	1.69
45	5.00	4.50	4.09	3.75	3.46	3.21	3.00	2.81	2.65	2.50	2.37	2.25	2.14	2.04	1.96	1.88	1.80	1.73
46	5.11	4.60	4.18	3.83	3.54	3.29	3.07	2.88	2.71	2.56	2.42	2.30	2.19	2.09	2.00	1.92	1.84	1.77
47	5.22	4.70	4.27	3.92	3.62	3.36	3.13	2.94	2.76	2.61	2.47	2.35	2.24	2.14	2.04	1.96	1.88	1.81
48	5.33	4.80	4.36	4.00	3.69	3.43	3.20	3.00	2.82	2.67	2.52	2.40	2.28	2.19	2.09	2.00	1.92	1.84
49	5.44	4.90	4.45	4.08	3.77	3.50	3.27	3.06	2.88	2.72	2.58	2.45	2.33	2.23	2.13	2.04	1.96	1.88
50	5.56	5.00	4.55	4.17	3.85	3.57	3.33	3.13	2.94	2.78	2.63	2.50	2.38	2.27	2.17	2.08	2.00	1.92
51	5.67	5.10	4.64	4.25	3.92	3.64	3.40	3.19	3.00	2.83	2.68	2.55	2.43	2.32	2.22	2.13	2.04	1.96
52	5.78	5.20	4.73	4.33	4.00	3.71	3.47	3.25	3.06	2.89	2.74	2.60	2.48	2.36	2.26	2.17	2.08	2.00
53	5.89	5.30	4.82	4.42	4.08	3.79	3.53	3.31	3.12	2.94	2.79	2.65	2.52	2.41	2.30	2.21	2.12	2.04
54	6.00	5.40	4.91	4.50	4.15	3.86	3.60	3.38	3.18	3.00	2.84	2.70	2.57	2.45	2.35	2.25	2.16	2.07
55	6.11	5.50	5.00	4.58	4.23	3.93	3.67	3.44	3.24	3.06	2.90	2.75	2.62	2.50	2.39	2.29	2.20	2.12
56	6.22	5.60	5.09	4.67	4.31	4.00	3.73	3.50	3.29	3.11	2.95	2.80	2.67	2.55	2.43	2.33	2.24	2.15
57	6.33	5.70	5.18	4.75	4.38	4.07	3.80	3.56	3.35	3.17	3.00	2.85	2.71	2.59	2.49	2.38	2.28	2.19
58	6.44	5.80	5.27	4.83	4.46	4.14	3.87	3.63	3.41	3.22	3.05	2.90	2.76	2.64	2.52	2.42	2.32	2.23
59	6.56	5.90	5.36	4.92	4.54	4.21	3.93	3.69	3.47	3.28	3.11	2.95	2.81	2.68	2.57	2.46	2.36	2.27
60	6.67	6.00	5.45	5.00	4.61	4.28	4.00	3.75	3.53	3.34	3.16	3.00	2.86	2.72	2.61	2.50	2.40	2.30
68	7.55	6.80	6.18	5.66	5.23	4.86	4.54	4.25	4.00	3.78	3.58	3.40	3.24	3.09	2.96	2.84	2.72	2.61
70	7.78	7.00	6.36	5.83	5.38	5.00	4.67	4.38	4.12	3.89	3.68	3.50	3.33	3.18	3.05	2.92	2.80	2.69
72	8.00	7.20	6.54	6.00	5.54	5.14	4.80	4.50	4.24	4.00	3.79	3.60	3.43	3.27	3.13	3.00	2.88	2.77
76			6.91	6.33	5.84	5.43	5.07	4.75	4.47	4.23	4.00	3.80	3.62	3.45	3.31	3.17	3.04	2.92
80			7.27	6.66	6.15	5.71	5.34	5.00	4.70	4.45	4.21	4.00	3.81	3.63	3.48	3.34	3.20	3.07
84				7.00	6.46	6.00	5.60	5.25	4.94	4.67	4.42	4.20	4.00	3.81	3.65	3.50	3.36	3.23
95					7.31	6.78	6.33	5.94	5.59	5.28	5.00	4.75	4.52	4.32	4.13	3.96	3.80	3.65
96					7.38	6.85	6.40	6.00	5.64	5.34	5.05	4.80	4.57	4.36	4.18	4.00	3.84	3.69
102						7.28	6.80	6.38	6.00	5.67	5.37	5.10	4.86	4.63	4.44	4.25	4.08	3.92
112								7.00	6.59	6.23	5.89	5.60	5.33	5.08	4.87	4.67	4.48	4.30

# SPROCKET DIAMETERS

Note: Values below are calculated and do not include manufacturing tolerances.

All dimensions are in inches unless otherwise indicated.

No. of Teeth	RS25 1/4" Pitch		
	Pitch Dia.	Outside Dia.	Caliper Dia.
9	.731	.837	.590
10	.809	.919	.679
11	.887	1.001	.748
12	.966	1.083	.836
13	1.045	1.164	.907
14	1.123	1.245	.993
15	1.203	1.326	1.066
16	1.282	1.407	1.152
17	1.361	1.487	1.225
18	1.440	1.568	1.310
19	1.519	1.648	1.384
20	1.598	1.728	1.468
21	1.677	1.809	1.543
22	1.757	1.889	1.627
23	1.836	1.969	1.702
24	1.915	2.049	1.785
25	1.995	2.129	1.861
26	2.074	2.209	1.944
28	2.233	2.369	2.103
30	2.392	2.529	2.262
32	2.551	2.688	2.421
35	2.789	2.928	2.656
36	2.868	3.008	2.738
40	3.186	3.327	3.056
45	3.584	3.725	3.452
48	3.822	3.964	3.692
54	4.300	4.442	4.170
60	4.777	4.920	4.647
70	5.572	5.717	5.442
72	5.731	5.876	5.601

No. of Teeth	RS35 3/8" Pitch		
	Pitch Dia.	Outside Dia.	Caliper Dia.
9	1.096	1.255	.880
10	1.214	1.379	1.014
11	1.331	1.502	1.118
12	1.449	1.625	1.249
13	1.567	1.746	1.356
14	1.685	1.868	1.485
15	1.804	1.989	1.594
16	1.922	2.110	1.722
17	2.041	2.231	1.832
18	2.160	2.352	1.960
19	2.278	2.472	2.071
20	2.397	2.593	2.197
21	2.516	2.713	2.309
22	2.635	2.833	2.435
23	2.754	2.953	2.548
24	2.873	3.073	2.673
25	2.992	3.194	2.786
26	3.111	3.313	2.911
27	3.230	3.434	3.025
28	3.349	3.553	3.149
30	3.588	3.793	3.388
32	3.826	4.032	3.626
35	4.183	4.392	3.979
36	4.303	4.511	4.103
40	4.780	4.990	4.580
42	5.018	5.229	4.818
45	5.376	5.588	5.173
48	5.734	5.946	5.534
54	6.449	6.664	6.249
60	7.165	7.380	6.965
70	8.358	8.575	8.158
72	8.597	8.814	8.397
80	9.552	9.770	9.352
84	10.029	10.247	9.829
96	11.461	11.680	11.261
112	13.371	13.590	13.171

No. of Teeth	RS40 1/2" Pitch		
	Pitch Dia.	Outside Dia.	Caliper Dia.
8	1.307	1.507	.995
9	1.462	1.674	1.127
10	1.618	1.839	1.305
11	1.775	2.003	1.444
12	1.932	2.166	1.620
13	2.089	2.328	1.761
14	2.247	2.490	1.934
15	2.405	2.652	2.079
16	2.563	2.814	2.250
17	2.721	2.974	2.397
18	2.879	3.136	2.567
19	3.038	3.292	2.715
20	3.196	3.457	2.883
21	3.355	3.618	3.033
22	3.513	3.778	3.201
23	3.672	3.938	3.351
24	3.831	4.098	3.518
25	3.989	4.258	3.669
26	4.148	4.418	3.835
27	4.307	4.578	3.987
28	4.465	4.738	4.153
29	4.625	4.898	4.305
30	4.783	5.057	4.471
31	4.942	5.217	4.623
32	5.101	5.376	4.788
33	5.260	5.536	4.941
34	5.419	5.696	5.107
35	5.578	5.856	5.260
36	5.737	6.015	5.425
38	6.055	6.334	5.742
40	6.373	6.653	6.061
42	6.691	6.972	6.379
44	7.009	7.291	6.696
45	7.168	7.450	6.851
46	7.327	7.609	7.014
47	7.486	7.769	7.169
48	7.645	7.928	7.332
50	7.963	8.248	7.650
54	8.599	8.884	8.286
60	9.554	9.840	9.241
70	11.145	11.433	10.832
72	11.463	11.752	11.151
80	12.736	13.026	12.423
84	13.372	13.663	13.059
96	15.282	15.573	14.969
112	17.827	18.121	17.515

No. of Teeth	RS50 5/8" Pitch		
	Pitch Dia.	Outside Dia.	Caliper Dia.
8	1.633	1.880	1.233
9	1.827	2.093	1.400
10	2.023	2.299	1.623
11	2.219	2.504	1.796
12	2.415	2.708	2.015
13	2.612	2.911	2.193
14	2.809	3.113	2.409
15	3.006	3.315	2.590
16	3.204	3.517	2.804
17	3.401	3.718	2.987
18	3.599	3.919	3.199
19	3.798	4.121	3.384
20	3.995	4.321	3.595
21	4.194	4.522	3.782
22	4.392	4.722	3.992
23	4.590	4.923	4.179
24	4.788	5.123	4.388
25	4.987	5.323	4.577
26	5.185	5.523	4.785
27	5.384	5.723	4.975
28	5.582	5.922	5.182
29	5.781	6.122	5.371
30	5.979	6.321	5.579
31	6.178	6.521	5.770
32	6.376	6.721	5.976
33	6.575	6.921	6.168
34	6.774	7.120	6.374
35	6.973	7.319	6.565
36	7.171	7.519	6.771
37	7.370	7.718	6.963
38	7.569	7.918	7.169
39	7.768	8.117	7.361
40	7.966	8.316	7.566
42	8.364	8.715	7.964
43	8.563	8.914	8.157
44	8.761	9.114	8.361
45	8.960	9.313	8.554
48	9.556	9.911	9.156
49	9.755	10.110	9.350
50	9.954	10.309	9.554
52	10.351	10.708	9.951
54	10.749	11.106	10.349
55	10.948	11.305	10.543
56	11.147	11.504	10.747
60	11.942	12.301	11.542
70	13.931	14.292	13.531
72	14.329	14.690	13.929
80	15.919	16.283	15.519
84	16.715	17.079	16.315
96	19.102	19.467	18.702
112	22.284	22.651	21.884

# SPROCKET DIAMETERS

Note: Values below are calculated and do not include manufacturing tolerances.

All dimensions are in inches unless otherwise indicated.

No. of Teeth	RS60 3/4" Pitch		
	Pitch Dia.	Outside Dia.	Caliper Dia.
8	1.959	2.260	1.491
9	2.193	2.511	1.691
10	2.427	2.759	1.958
11	2.662	3.005	2.166
12	2.898	3.249	2.429
13	3.134	3.493	2.642
14	3.371	3.736	2.902
15	3.608	3.978	3.119
16	3.845	4.220	3.375
17	4.082	4.462	3.595
18	4.319	4.703	3.850
19	4.557	4.945	4.072
20	4.794	5.186	4.325
21	5.033	5.426	4.549
22	5.270	5.666	4.801
23	5.508	5.907	5.026
24	5.746	6.147	5.277
25	5.984	6.387	5.503
26	6.222	6.627	5.753
27	6.461	6.867	5.980
28	6.698	7.106	6.229
29	6.937	7.346	6.458
30	7.175	7.586	6.706
31	7.413	7.826	6.935
32	7.652	8.065	7.183
33	7.890	8.305	7.412
34	8.129	8.544	7.660
35	8.367	8.783	7.889
36	8.606	9.023	8.137
37	8.844	9.262	8.367
38	9.083	9.501	8.614
39	9.321	9.740	8.844
40	9.560	9.980	9.091
41	9.798	10.219	9.321
42	10.037	10.458	9.568
44	10.514	10.937	10.045
45	10.752	11.176	10.276
46	10.991	11.414	10.522
48	11.468	11.893	10.999
49	11.706	12.132	11.231
50	11.945	12.371	11.476
52	12.422	12.849	11.953
54	12.889	13.327	12.430
60	14.330	14.761	13.861
70	16.717	17.150	16.248
72	17.195	17.628	16.726
80	19.103	19.539	18.634
84	20.058	20.495	19.589
96	22.922	23.360	22.453
112	26.741	27.181	26.272

No. of Teeth	RS80 1" Pitch		
	Pitch Dia.	Outside Dia.	Caliper Dia.
8	2.613	3.014	1.988
9	2.924	3.348	2.254
10	3.236	3.678	2.611
11	3.550	4.006	2.888
12	3.864	4.332	3.239
13	4.179	4.657	3.523
14	4.494	4.981	3.869
15	4.810	5.304	4.158
16	5.126	5.627	4.501
17	5.442	5.949	4.794
18	5.759	6.271	5.134
19	6.076	6.593	5.430
20	6.392	6.914	5.767
21	6.710	7.235	6.066
22	7.027	7.555	6.402
23	7.344	7.876	6.702
24	7.661	8.196	7.036
25	7.979	8.526	7.338
26	8.296	8.836	7.671
27	8.614	9.156	7.974
28	8.931	9.475	8.306
29	9.249	9.795	8.611
30	9.567	10.114	8.942
31	9.884	10.434	9.247
32	10.202	10.753	9.577
33	10.520	11.073	9.883
34	10.838	11.392	10.213
35	11.156	11.711	10.520
36	11.474	12.030	10.849
37	11.792	12.349	11.156
38	12.110	12.668	11.485
40	12.746	13.306	12.121
42	13.382	13.944	12.757
45	14.336	14.901	13.702
46	14.654	15.219	14.029
48	15.290	15.857	14.665
49	15.608	16.176	14.975
54	17.198	17.769	16.573
60	19.107	19.681	18.482
65	20.698	21.270	20.067
70	22.289	22.867	21.644
72	22.926	23.504	22.301
80	25.471	26.052	24.846
84	26.744	27.326	26.119
96	30.563	31.147	29.938
112	35.655	36.241	35.030

No. of Teeth	RS100 1 1/4" Pitch		
	Pitch Dia.	Outside Dia.	Caliper Dia.
8	3.266	3.770	2.516
9	3.655	4.185	2.849
10	4.045	4.598	3.295
11	4.438	5.008	3.642
12	4.830	5.415	4.080
13	5.224	5.821	4.435
14	5.618	6.226	4.868
15	6.013	6.630	5.229
16	6.408	7.034	5.658
17	6.803	7.436	6.024
18	7.199	7.839	6.449
19	7.595	8.241	6.819
20	7.990	8.643	7.240
21	8.388	9.044	7.613
22	8.784	9.444	8.034
23	9.180	9.845	8.409
24	9.576	10.245	8.826
25	9.974	10.645	9.204
26	10.370	11.045	9.620
27	10.768	11.445	9.999
28	11.164	11.844	10.414
30	11.959	12.643	11.209
32	12.753	13.441	12.003
35	13.945	14.639	13.181
36	14.343	15.038	13.593
40	15.933	16.633	15.183
42	16.728	17.430	15.978
45	17.920	18.626	17.159
48	19.113	19.821	18.363
54	21.498	22.211	20.748
60	23.884	24.601	23.134
70	27.861	28.584	27.111
72	28.657	29.380	27.908
80	31.839	32.565	31.089
84	33.430	34.158	32.680
90	35.817	36.545	35.068
96	38.204	38.934	37.454

# SPROCKET DIAMETERS

Note: Values below are calculated and do not include manufacturing tolerances.

All dimensions are in inches unless otherwise indicated.

No. of Teeth	RS120 1 <sup>1/2</sup> " Pitch		
	Pitch Dia.	Outside Dia.	Caliper Dia.
9	4.386	5.022	3.444
10	4.854	5.517	3.979
11	5.325	6.009	4.395
12	5.796	6.498	4.921
13	6.269	6.986	5.347
14	6.741	7.472	5.866
15	7.215	7.956	6.300
16	7.689	8.441	6.814
17	8.163	8.924	7.254
18	8.639	9.407	7.764
19	9.114	9.890	8.207
20	9.588	10.371	8.713
21	10.065	10.853	9.161
22	10.541	11.333	9.666
23	11.016	11.814	10.115
24	11.492	12.294	10.617
25	11.969	12.774	11.070
26	12.444	13.254	11.569
27	12.921	13.734	12.024
28	13.397	14.213	12.522
30	14.351	15.171	13.476
32	15.303	16.130	14.428
35	16.734	17.567	15.842
36	17.211	18.045	16.336
40	19.119	19.959	18.244
42	20.073	20.916	19.198
45	21.504	22.352	20.615
48	22.935	23.786	22.060
54	25.797	26.654	24.922
60	28.661	29.522	27.786
70	33.434	34.301	32.559
80	38.207	39.078	37.332

No. of Teeth	RS160 2" Pitch		
	Pitch Dia.	Outside Dia.	Caliper Dia.
8	5.226	6.028	4.101
9	5.848	6.696	4.635
10	6.472	7.356	5.347
11	7.100	8.012	5.902
12	7.728	8.664	6.603
13	8.358	9.314	7.171
14	8.988	9.962	7.863
15	9.620	10.608	8.442
16	10.252	11.254	9.127
17	10.844	11.898	9.713
18	11.518	12.542	10.393
19	12.152	13.186	10.985
20	12.784	13.828	11.659
21	13.420	14.470	12.256
22	14.054	15.110	12.929
23	14.688	15.752	13.529
24	15.322	16.392	14.197
25	15.958	17.032	14.801
26	16.592	17.672	15.467
27	17.228	18.312	16.073
28	17.862	18.950	16.737
30	19.134	20.228	18.009
35	22.312	23.422	21.164
36	22.948	24.060	21.823
40	25.492	26.612	24.367
45	28.672	29.802	27.529
48	30.580	31.714	29.455
54	34.396	35.538	33.271
60	38.214	39.362	37.089
70	44.578	45.734	43.453
80	50.942	52.104	49.817

No. of Teeth	RS200 2 <sup>1/2</sup> " Pitch		
	Pitch Dia.	Outside Dia.	Caliper Dia.
10	8.090	9.195	6.528
11	8.872	10.020	7.219
12	9.660	10.830	8.098
13	10.447	11.640	8.808
14	11.235	12.460	9.673
15	12.025	13.260	10.397
16	12.815	14.070	11.253
17	13.605	14.870	11.985
18	14.397	15.680	12.835
19	15.190	16.480	13.576
20	15.982	17.290	14.420
21	16.775	18.090	15.166
22	17.567	18.890	16.005
23	18.360	19.690	16.755
24	19.152	20.490	17.590
25	19.947	21.290	18.346
26	20.740	22.090	19.178
28	22.330	23.690	20.768
30	23.917	25.290	22.355
32	25.505	26.880	23.943
35	27.890	29.280	26.300
40	31.865	33.270	30.303
45	35.840	37.250	34.256
54	42.995	44.420	41.433
60	47.767	49.200	46.205

No. of Teeth	RS140 1 <sup>3/4</sup> " Pitch		
	Pitch Dia.	Outside Dia.	Caliper Dia.
11	6.213	7.011	5.148
12	6.762	7.581	5.762
13	7.313	8.150	6.259
14	7.865	8.717	6.865
15	8.418	9.282	7.371
16	8.971	9.847	7.971
17	9.524	10.411	8.483
18	10.078	10.974	9.078
19	10.633	11.538	9.596
20	11.186	12.100	10.186
21	11.743	12.661	10.709
22	12.297	13.221	11.297
23	12.852	13.783	11.822
24	13.407	14.343	12.407
25	13.963	14.903	12.935
26	14.518	15.463	13.518
28	15.629	16.581	14.629
30	16.742	17.700	15.742
32	17.854	18.818	16.854
35	19.523	20.494	18.503
36	20.080	21.053	19.080
40	22.306	23.286	21.306
45	25.088	26.077	24.072
48	26.758	27.750	25.758
54	30.097	31.096	29.097
60	33.437	34.442	32.437
70	39.006	40.017	38.006
80	44.574	45.591	43.574

No. of Teeth	RS180 2 <sup>1/4</sup> " Pitch		
	Pitch Dia.	Outside Dia.	Caliper Dia.
11	7.986	9.010	6.499
12	8.693	9.750	7.287
13	9.402	10.480	7.927
14	10.111	11.210	8.705
15	10.822	11.940	9.357
16	11.533	12.660	10.127
17	12.245	13.390	10.787
18	12.957	14.110	11.551
19	13.670	14.830	12.217
20	14.383	15.560	12.977
21	15.096	16.280	13.648
22	15.810	17.000	14.404
23	16.524	17.720	15.079
24	17.238	18.440	15.832
25	17.952	19.160	16.511
28	20.096	21.320	18.690
30	21.525	22.760	20.119
35	25.101	26.350	23.669
40	28.677	29.940	27.271
45	32.255	33.530	30.829
54	38.695	39.980	37.290
60	42.992	44.280	41.586

No. of Teeth	RS240 3" Pitch		
	Pitch Dia.	Outside Dia.	Caliper Dia.
10	9.708	11.030	7.833
11	10.648	12.020	8.665
12	11.591	13.000	9.716
13	12.536	13.970	10.569
14	13.482	14.940	11.607
15	14.429	15.910	12.475
16	15.377	16.880	13.502
17	16.327	17.850	14.382
18	17.276	18.810	15.401
19	18.227	19.780	16.289
20	19.177	20.740	17.302
21	20.129	21.700	18.197
25	23.936	25.550	22.014
30	28.700	30.340	26.825
35	33.467	35.130	31.559
40	38.237	39.920	36.362
45	43.007	44.700	41.106
54	51.595	53.310	49.720
60	57.322	59.040	55.447

# STANDARD KEYWAYS & SET SCREWS

All dimensions are in inches unless otherwise indicated.

"Inch" Standard Keyways and Set Screw						
Shaft Diameter (in.)		Keyway (in.)		Key (in.)		Set Screw Diameter
From	To	Width	Depth	Width	Depth	
5/16	7/16	3/32	3/64	3/32	3/32	8-32
1/2	9/16	1/8	1/16	1/8	1/8	1-24
5/8	7/8	3/16	3/32	3/16	3/16	1/4
15/16	1-1/4	1/4	1/8	1/4	1/4	5/16
1-5/16	1-3/8	5/16	5/32	5/16	5/16	5/16
1-7/16	1-3/4	3/8	3/16	3/8	3/8	3/8
1-13/16	2-1/4	1/2	1/4	1/2	1/2	1/2
2-5/16	2-3/4	5/8	5/16	5/8	5/8	5/8
2-13/16	3-1/4	3/4	3/8	3/4	3/4	3/4
3-5/16	3-3/4	7/8	7/16	7/8	7/8	3/4
3-13/16	4-1/2	1	1/2	1	1	3/4
4-9/16	5-1/2	1-1/4	5/8	1-1/4	1-1/4	3/4
5-9/16	6-1/2	1-1/2	3/4	1-1/2	1-1/2	1
6-9/16	7-1/2	1-3/4	7/8	1-3/4	1-1/2	1
7-9/16	8-15/16	2	1	2	1-1/2	1
9	10-15/16	2-1/2	1-1/4	2-1/2	1-3/4	1

"Metric" Standard Keyways and Set Screw					
Shaft Diameter (mm)		Keyway (mm)		Key (mm)	
From	Including	Width	Depth	Width	Depth
6	8	2	1	2	2
8	10	3	1.4	3	3
10	12	4	1.8	4	4
12	17	5	2.3	5	5
17	22	6	2.8	6	6
22	30	8	3.3	8	7
30	38	10	3.3	10	8
38	44	12	3.3	12	8
44	50	14	3.8	14	9
50	58	16	4.3	16	10
58	65	18	4.4	18	11
65	75	20	4.9	20	12
75	85	22	5.4	22	14
85	95	25	5.4	25	14
95	110	28	6.4	28	16
110	130	32	7.4	32	18
130	150	36	8.4	36	20

Knurled Cup Point Set Screws					
Inch Cup Point Set Screw			Metric Cup Point Set Screw		
Nominal Size	Tightening Torque (In-Lbs.)		Nominal Size	Tightening Torque (Nm) (In-Lbs.)	
0	1.1		1.6	0.1	0.89
1	2.1		2	0.2	1.77
2	2.1		2.5	0.6	5.31
3	6.0		3	1.0	8.85
4	6.0		4	2.1	18.59
5	11		5	4.7	41.60
6	11		6	7.7	68.15
8	23		8	17.8	158
10	40		10	35.0	310
1/4	94		12	55.0	487
5/16	183		16	125	1106
3/8	317		20	250	2213
7/16	502		24	425	3762
1/2	750				
5/8	1460				
3/4	2520				
7/8	5720				
1	8000				



# TAPER-LOCK® SHALLOW KEYWAY DIMENSIONS

All dimensions are in inches unless otherwise indicated.

TAPER-LOCK Bushing Number	Bushing Bore ID	Keyway Width x Height	TAPER-LOCK Bushing Number	Bushing Bore ID	Keyway Width x Height	TAPER-LOCK Bushing Number	Bushing Bore ID	Keyway Width x Height
1008	15/16	1/4 X 1/16	2525	2-7/16	5/8 x 3/16	3535	3-7/8	1 x 1/4
1008	1	1/4 X 1/16	2525	2-1/2	5/8 x 3/16	3535	3-15/16	1 x 1/4
1108	1-1/16	1/4 X 1/16	3020	2-13/16	3/4 x 1/8	4040	3-11/19	7/8 x 3/16
1108	1-1/8	1/4 X 1/16	3020	2-7/8	3/4 x 1/8	4040	3-3/4	7/8 x 3/16
1310	1-7/16	3/8 X 1/8	3020	2-15/16	3/4 x 1/8	4040	3-7/8	1 x 1/4
1610	1-9/16	3/8 X 1/8	3020	3	3/4 x 1/8	4040	3-15/16	1 x 1/4
1610	1-5/8	3/8 X 1/8	3020	3-1/8	3/4 x 1/4	4040	4	1 x 1/4
1610	1-11/16	3/8 X 1/8	3020	3-3/16	3/4 x 1/4	4040	4-1/8	1 x 1/4
1615	1-9/16	3/8 X 1/8	3020	3-1/4	3/4 x 1/4	4040	4-3/16	1 x 1/4
1615	1-5/8	3/8 X 1/8	3030	2-7/8	3/4 x 1/8	4040	4-1/4	1 x 1/4
1615	1-11/16	3/8 X 1/8	3030	2-15/16	3/4 x 1/8	4040	4-3/8	1 x 1/4
2012	1-15/16	1/2 X 3/16	3030	3	3/4 x 1/8	4040	4-7/16	1 x 1/4
2012	2	1/2 X 3/16	3030	3-1/8	3/4 x 1/8	4545	4-3/8	1 x 1/4
2012	2-1/8	1/2 X 3/16	3030	3-3/16	3/4 x 1/8	4545	4-7/16	1 x 1/4
2517	2-5/16	5/8 x 3/16	3030	3-1/4	3/4 x 1/4	4545	4-1/2	1 x 1/4
2517	2-3/8	5/8 x 3/16	3535	3-5/16	7/8 x 1/8	4545	4-3/4	1-1/4 x 1/4
2517	2-7/16	5/8 x 3/16	3535	3-3/8	7/8 x 3/16	4545	4-7/8	1-1/4 x 1/4
2517	2-1/2	5/8 x 3/16	3535	3-7/16	7/8 x 3/16	4545	4-15/16	1-1/4 x 1/4
2517	2-5/8	5/8 x 3/16	3535	3-1/2	7/8 x 3/16	5050	4-7/8	1-1/4 x 1/4
2517	2-11/16	5/8 x 3/16	3535	3-5/8	7/8 x 1/4			
2525	2-5/16	5/8 x 3/16	3535	3-11/16	7/8 x 3/16			
2525	2-3/8	5/8 x 3/16	3535	3-3/4	7/8 x 3/16			

# QD<sup>®</sup> SHALLOW KEYWAY DIMENSIONS

All dimensions are in inches unless otherwise indicated.

QD Bushing	Bushing Bore ID	Keyway WidthxHeight	QD Bushing	Bushing Bore ID	Keyway WidthxHeight	QD Bushing	Bushing Bore ID	Keyway WidthxHeight
JA	1-1/16	1/4 X 1/16	SF	2-11/16	5/8 X 1/16	J	4-3/16	1 X 1/8
JA	1-1/8	1/4 X 1/16	SF	2-3/4	5/8 X 1/16	J	4-1/4	1 X 1/8
JA	1-3/16	1/4 X 1/16	SF	2-13/16	3/4 X 1/8	J	4-3/8	1 X 1/8
SH	1-7/16	3/8 X 1/16	SF	2-7/8	3/4 X 1/32	J	4-7/16	1 X 1/8
SH	1-1/2	3/8 X 1/16	SF	2-15/16	3/4 X 1/32	J	4-1/2	1 X 1/8
SH	1-9/16	3/8 X 1/16	E	2-15/16	3/4 X 1/8	M	4-7/8	1-1/4 X 1/4
SH	1-5/8	3/8 X 1/16	E	3	3/4 X 1/8	M	4-15/16	1-1/4 X 1/4
SDS	1-11/16	3/8 x 1/8	E	3-1/8	3/4 X 1/8	M	5	1-1/4 X 1/4
SDS	1-3/74	3/8 x 1/8	E	3-3/16	3/4 X 1/8	M	5-1/8	1-1/4 X 1/4
SDS	1-13/16	1/2 x 1/16	E	3-1/4	3/4 X 1/8	M	5-3/16	1-1/4 X 1/4
SDS	1-7/8	1/2 x 1/16	E	3-5/16	7/8 X 1/8	M	5-1/4	1-1/4 X 1/4
SDS	1-15/16	1/2 x 1/16	E	3-3/8	7/8 X 1/16	M	5-7/16	1-1/4 X 1/4
SD	1-3/4	3/8 X 1/8	E	3-7/16	7/8 X 1/16	M	5-1/2	1-1/4 X 1/4
SD	1-13/16	1/2 X 1/16	E	3-1/2	7/8 X 1/16	N	5-1/8	1-1/4 X 1/4
SD	1-7/8	1/2 X 1/16	F	3-3/8	7/8 X 3/16	N	5-1/8	1-1/4 X 1/4
SD	1-15/16	1/2 X 1/16	F	3-7/16	7/8 X 3/16	N	5-1/4	1-1/4 X 1/4
SK	2-3/16	1/2 X 3/16	F	3-1/2	7/8 X 3/16	N	5-7/16	1-1/4 X 1/4
SK	2-1/4	1/2 X 3/16	F	3-5/8	7/8 X 3/16	N	5-1/2	1-1/4 X 1/4
SK	2-5/16	5/8 X 1/16	F	3-11/16	7/8 X 3/16	N	5-3/4	1-1/2 X 1/8
SK	2-3/8	5/8 X 1/16	F	3-3/4	7/8 X 3/16	N	5-7/8	1-1/2 X 1/8
SK	2-7/16	5/8 X 1/16	F	3-7/8	1 X 1/8	N	5-15/16	1-1/2 X 1/8
SK	2-1/2	5/8 X 1/16	F	3-15/16	1 X 1/8	N	6	1-1/2 X 1/8
SF	2-3/8	5/8 X 3/16	J	3-7/8	1 X 1/8	P	6	1-1/2 X 1/4
SF	3-7/16	5/8 X 3/16	J	3-15/16	1 X 1/8	P	6-7/16	1-1/2 X 1/4
SF	2-1/2	5/8 X 3/16	J	4	1 X 1/8	P	6-1/2	1-1/2 X 1/4
SF	2-5/8	5/8 X 1/16	J	4-1/8	1 X 1/8	P	7	1-3/4 X 1/8

# MAINTENANCE CHECKLIST

Regardless of the application, all chain systems should be inspected on a regularly scheduled basis for worn, damaged or broken parts, possible interference by other system components, and proper lubrication. Normal maintenance procedures can prevent most of the conditions described below. Carefully inspect roller chain drives on the same schedule as associated equipment.

## **SPROCKET MISALIGNMENT**

Wear on the sides of sprocket teeth generally indicates improper installation of sprockets and/or shafts. If shafts are out of parallel or not in the same plane, non-symmetrical wear will appear on sprockets or chain rollers.

After proper alignment is made, retighten set screws in sprocket hubs.

## **CHAIN WEAR AND ELONGATION**

Normal wear will cause some increase in chain length. However, if a sudden increase in elongation occurs, look for severe wear on the tips of sprocket teeth. This may be caused by any of the following: excessive loading or shock loading, displacement and/or wear in bearings, displacement of takeups, or under-designed drive. Elongation of 3% or more may be an indication that chain and/or sprockets should be replaced.

Before replacing chain or sprockets, recalculate initial drive design. Check chain for broken parts. Check chain tension if there is too much accumulated slack in the drive.

## **BROKEN CHAIN PARTS**

Generally caused by an overload drive, extreme misalignment, excessive elongation causing chain to jump sprocket teeth, heavy shock, improper drive design geometry, or foreign objects.

Recalculate initial drive design and make necessary corrections. Inspect sprockets and shafts for proper alignment or looseness.

## **LINK PLATE WEAR**

Wear on edges of outer sides of link plates may be caused by chain contacting a case or fixed object.

Remove or relocate fixed object. Readjust chain properly.

## **EXCESSIVE NOISE**

Can be caused by broken links and chain rollers, extreme misalignment, elongation, chain jumping sprocket teeth, loose sprockets, broken teeth, accumulation of dirt packed into the chain or sprocket teeth, interference by foreign objects, or contacting a fixed object.

Check for worn, broken, or missing parts. Check alignment of shafts and/or sprockets.

## **EXCESSIVE VIBRATION**

Unbalanced rotating parts, broken or missing rollers, too much chain slack, loose or misaligned sprockets or shafts.

Inspect chain and drive equipment. Replace or readjust as needed.

## **IMPROPER LUBRICATION**

Light or dark brown discoloration of pin-bushing joints and connecting link pins, or brown-red oxide color in oil may indicate chain is not dipping into the oil reservoir, or drip lubricator or spray is plugged.

Carefully clean and dry chain, immerse in oil, and reinstall. Change oil in chain case and flush case. Determine that oil supply is adequate and unimpeded.

## **SUGGESTED REPLACEMENT PROCEDURES**

Chain parts should never be altered or tampered with by makeshift repairs and/or with parts or components which have not been authorized by the company.

# WARNING

## **USE CARE TO PREVENT INJURY COMPLY WITH THE FOLLOWING TO AVOID SERIOUS PERSONAL INJURY:**

1. Guards must be provided on all chain and sprocket installations in accordance with provisions of ANSI/ASME B15.1—2000 (R2008) “Safety Standards for Mechanical Power Transmission Apparatus,” and ANSI/ASME B20.1—2012 “Safety Standards for Conveyors and Related Equipment,” or other applicable safety standards. When revisions of these standards are published, the updated edition shall apply.
2. Always lock out the power switch before installing, removing, lubricating or servicing a chain system.
3. When connecting or disconnecting chain:
  - a. Eye protection is required. Wear safety glasses, protective clothing, gloves and safety shoes.
  - b. Support the chain to prevent uncontrolled movement of chain and parts.
  - c. Use of pressing equipment is recommended. Tools must be in good condition and properly used.
  - d. Determine correct direction for pin/rivet removal or insertion.

UST-86 REV. 2-13

# OTHER SPROCKET TECHNICAL CONSIDERATIONS

## Other Considerations

When determining whether you need replacement sprockets, consider the following important points:

### Chain Interaction

The chain-sprocket interaction is the criterion upon which most users make their judgments about replacing sprockets. If the chain engages and disengages the sprocket smoothly without hanging up or snapping into place, most people will not replace it. If a chain does start to hang up on the sprocket, damaging chain overload conditions can develop rapidly. We suggest replacing sprockets before hang-up develops.

### Reversible

Almost all sprockets are reversible. The key to being able to reverse sprockets is symmetry. If the sprockets are symmetrical from side to side, then they can be reversed. Reversing is not suggested in most circumstances, especially with those applications that wear the sprocket bottom diameter.

### New Chain

We suggest you order new sprockets when chain is replaced. New sprockets ensure proper chain interaction and also provide maximum wear performance.

### Attachment Clearance

Any time an attachment is in the area between, above, or below the sidebars, make sure the attachment does not interfere with sprocket action.

### Relief Pocket (Mud Relief)

In applications where material buildup may be a problem, the bottom of the tooth pocket can be beveled on the side to allow the material to "squeeze" out. This reduction of contact area is not critical because the pressure on the bottom of the pocket is very light in horizontal conveyors. Other relief styles may be necessary for vertical conveyors.

### Advantages of Using Larger Sprockets

Choose the largest sprocket that will fit your application. Small sprockets cause greater shock and consequently more wear on both chain and sprockets. There are several reasons for this.

1. To engage small sprockets, chain must flex more which causes increased rotation of the pin in the bushing. Since this is one of the major causes of chain wear, this flexing action should be minimized.
2. Small sprockets with fewer teeth wear out much faster than sprockets with more teeth. More teeth provide an opportunity to distribute the wearing action.
3. Larger sprockets cause smoother operation because the greater number of teeth will pick up the load more frequently.

## Chordal Action

Chordal action is a very important concept in sprocket function. A sprocket is a collection of chords, or straight segments, that approximate a circle. The more teeth a sprocket has, the closer the chords are to a circle.

The problem with a chordal form is that the lineal output is not consistent. Since the sprocket is not a perfect circle, the distance from the shaft center to the chain center line varies. As this distance varies, so does the lineal output (assuming a constant shaft rotational speed).

A hexagon inscribed by a circle represents the six-tooth sprocket shown below. You can see that the distance from the center to the corner is different than from the center to the middle of the side. The corner would be the equivalent to the chain joint center, and the side is equivalent to the chain center line at mid-pitch.

### Minimum Chain Speed

$$V_{min} = r\omega$$

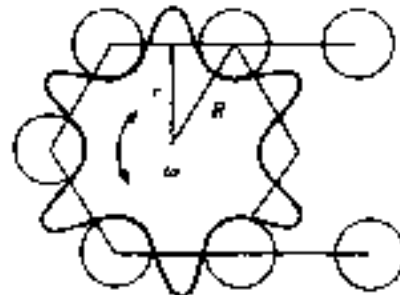

$$V_1 = .2618 (PD) \cos (180/T) N$$

### Maximum Chain Speed

$$V_{max} = R\omega$$

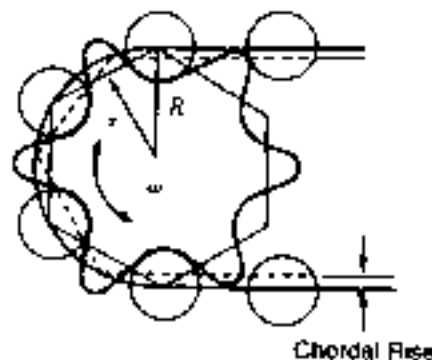

$$V_2 = .2618 (PD) N$$

Where  
 V1 and V2 in fpm  
 N in r.p.m.  
 PD in pitch diameter, in inches

# OTHER SPROCKET TECHNICAL CONSIDERATIONS

## Sprockets Keyed-In-Line

When two strands of chain run parallel with each other and they are to be timed identically, it is important to have the keyway position to be in the same relationship on both sprockets. This is referred to, and should be ordered as “keyed-in-line” or “matched in pairs” to obtain this feature (**Figure 1**).

## Sprocket Size

Use the largest diameter conveyor sprocket that space and economics permit. This minimizes chain speed variations and pulsations and reduces wear to the chain and sprocket.

## Sprocket Life

When sprockets are worn, the chain tends to cling to the sprockets or vibrate. The amount of allowable wear depends on the application type and chain size. Wear to a depth of 0.12" (3 mm) to 0.24" (6 mm) is usually a sign that the existing sprocket should be replaced, illustrated in **Figure 2**.

If the sprocket teeth are worn, the alignment may be incorrect. Proper axial alignment of the sprockets will help reduce or even eliminate wear of sprocket teeth, illustrated in **Figure 3**.

**Figure 1**

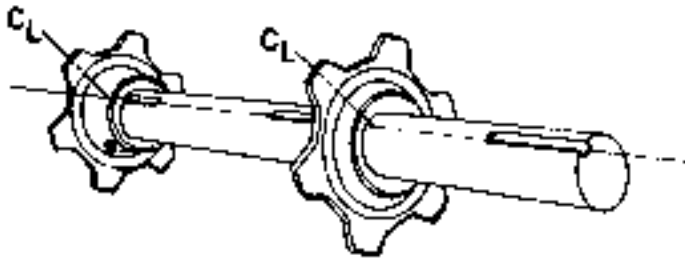

**Figure 2 - Sprocket Wear**

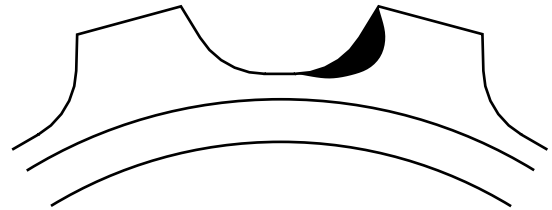

**Figure 3 - Sprocket Tooth Wear**

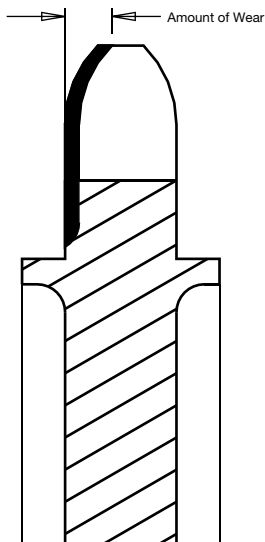

# TERMS AND CONDITIONS OF SALE

## PRICE-PAYMENT

The prices stated, if any, are those in effect on the date hereof and are subject to change based on prices in effect on the date of shipment. Interest at the rate of 18% per annum shall be charged on overdue payments. Prices are for Seller's standard packaging only, and F.O.B. Seller's plant or warehouse. All orders are subject to credit approval. Terms of payment are net, 30 days. In the event of non-payment by Buyer, Buyer shall pay all of Seller's costs of collection, including reasonable attorneys' fees. Up to 5% over or under the specified quantity for made-to-order products may be shipped at Seller's option.

## PERFORMANCE-CHANGES-DELAYS

- (a) Any time for delivery stated herein is approximate. Delivery shall be deemed complete by tender of the products to a common carrier. Partial shipments are permitted.
- (b) Orders are not subject to cancellation or revision, in whole or in part, without written approval of Seller.
- (c) Should Buyer cause changes to be made in the design or construction of said products, or otherwise delay or interrupt the progress of the work hereunder, Buyer will reimburse Seller for any additional expenses arising therefrom.
- (d) Seller shall not be liable for any delay caused by acts of God, riot or civil commotion, government orders, rules, regulations, suspensions or requisitions of any kind, strikes or other stoppages of labor or shortage in the supply of labor or material, fire casualties or accidents, or any cause, whether of the same or a different character, beyond Seller's control. Any such delay shall extend the time for delivery of the products. Delay in delivery of any installment shall not relieve Buyer of its obligation to accept remaining deliveries.
- (e) If delays due to Buyer's fault exceed 60 days in the aggregate, the entire purchase price shall be due and payable to Seller on demand.

## RISK OF LOSS

After delivery to the carrier, Buyer assumes the risk of all loss or damage to the products resulting from any cause whatever.

## LIMITED WARRANTY

Products manufactured by Seller: (a) conform to the design and specifications, if any, expressly agreed to in writing by Seller; and (b) are free of defects in workmanship and materials at the time of shipment. The warranties set forth in the preceding sentence are exclusive of all other warranties, express or implied, and extend only to Buyer and to no other person. **ALL WARRANTIES OF MERCHANTABILITY OR FITNESS FOR A PARTICULAR PURPOSE ARE HEREBY EXCLUDED.**

## NON-RELIANCE

Buyer is not relying upon any advice, representations or warranties (except the warranties expressly set forth above) of Seller, or upon Seller's skill or judgment regarding the Seller's products. Buyer is solely responsible for the design and specifications of the products, including without limitation, the determination of suitability for Buyer's application of the products.

## CLAIMS

- (a) Any claim relating to quantity or type shall be made to Seller in writing within 7 days after receipt of the products; any such claim made thereafter shall be barred.
- (b) Any claim under the above-stated Limited Warranty shall be made to Seller in writing within three (3) months after receipt of the products; any such claim made thereafter shall be barred.
- (c) Seller's liability for breach of warranty or otherwise is limited to repair or replacement, at Seller's option, of non-conforming or defective products. Buyer waives all other remedies, including, but not limited to, all rights to consequential, special or incidental damages, including, but not limited to, damages resulting from personal injury, death or damage to or loss of use of property.
- (d) Repair, alteration, neglect or misuse of the products shall void all applicable warranties.

## INDEMNIFICATION

Buyer will indemnify, defend and hold Seller harmless from all loss, liability, damage and expense, including attorneys' fees, arising out of any claim (a) for infringement of any patent, trademark, copyright, misappropriation of trade secrets, unfair competition or similar charge by any products supplied by Seller in accordance with the design or specifications furnished by Buyer, or (b) arising out of or connected with the products or any items into which the products are incorporated, including, but not limited to, any claim for product liability (whether or not based on negligence or strict liability of Seller), breach of warranty, breach of contract or otherwise.

## DUTIES AND TAXES

In addition to the specified purchase price, Buyer will pay any and all federal, state or local taxes, duties, excises, license fees and other charges levied, assessed or imposed upon Seller due to the manufacture, sale, purchase or delivery of the products. Buyer shall also pay the cost by which such manufacture is increased by reason of any law, ordinance or regulation adopted or promulgated by any government or governmental subdivision, department or agency, or other source, after the date hereof, but prior to the completion and delivery hereunder.

## SPECIFICATIONS, DRAWINGS, PATTERNS AND TOOLS

Seller's specifications, drawings, patterns and tooling shall be the sole and exclusive property of Seller unless otherwise agreed in writing.

## ENTIRE AGREEMENT

These terms and conditions constitute the entire agreement between Buyer and Seller and supersede any inconsistent terms and conditions, whether contained in Buyer's purchase order or otherwise, and whether made heretofore or hereafter. No statement or writing subsequent to the date hereof which purports to modify or add to the terms and conditions hereof shall be binding unless consented to in writing, which makes specific reference hereto, and which has been signed by the party against which enforcement thereof is sought. Seller reserves the right to change these terms and conditions without prior notice.

## RETURNED GOODS

No goods will be accepted for return without prior written authorization by Seller. Freight must be prepaid on all such returns, and each return is subject to inspection and acceptance by Seller to assure the goods are in a "resalable" condition. A minimum 10% handling and restocking charge will be applied to all authorized returns. Special or made-to-order goods are NOT returnable. Attachment chains returned are at the manufacturer's discretion.