

TSUBAKI CAM CLUTCH BR-HT SERIES

One-Way clutch

*Torque limiter model
and
Tension release model*



Ideal integral backstop

The BR-HT series Torque Limiter model is a combination of a centrifugal lift-off cam clutch and a torque limiter function in case of unbalanced load in multi drives.

The BR-HT series Tension Release model has a mechanical on-off system installed with the torque limiter function.

Both models are ideal for inclined belt conveyors for safety and ease of maintenance.



Application example for Torque limiter modal (Dual drive inclined belt conveyor)

Features

- 1.Sharing of the backstop load in case of an unbalanced situation due to the backlash of gears and couplings.
- 2.Reduce belt tension in case of abnormal load by motor stall torque.

BR-HT Torque limiter model

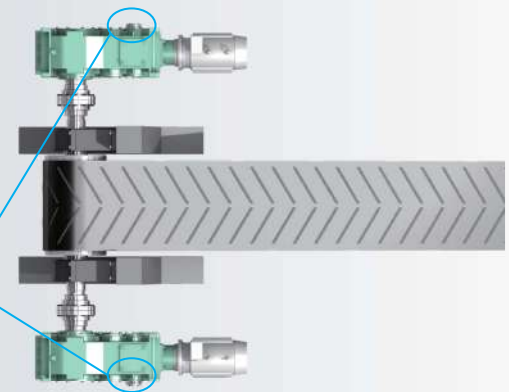

Application example for Tension release model (Tandem drive inclined belt conveyor)

Features

- 1.Perfect release mechanism to release belt tension in case of jamming.
- 2.Ideal for maintenance allowing belt to move backwards.
- 3.Sharing of the backstop load in case of an unbalanced situation due to the backlash of gears and couplings.
- 4.Reduce belt tension in case of abnormal load by motor stall torque.

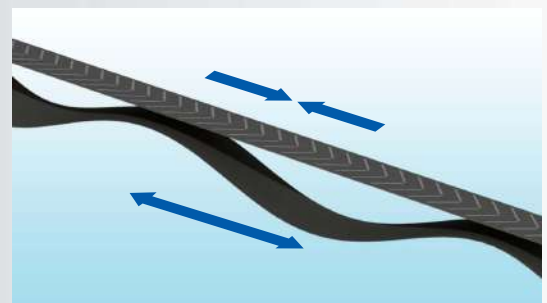

for dual or tandem drives

Details of Torque limiter model

Details of Tension release model

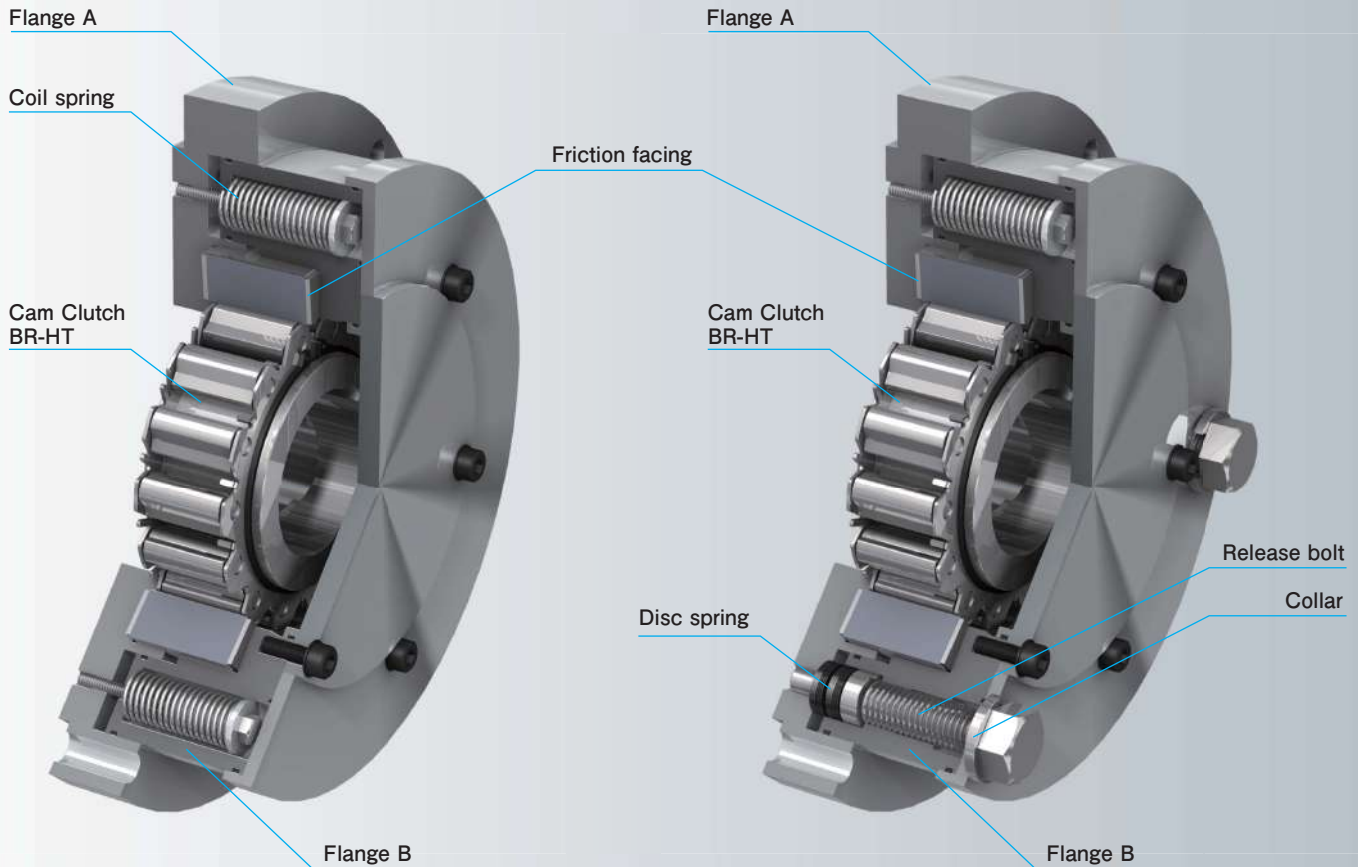

Features of BR-HT

1) Lift-off design

Ideal for long life by lift-off function

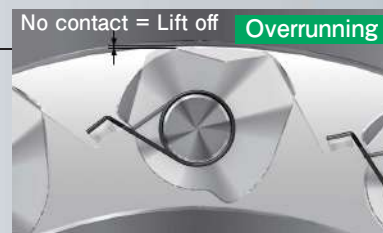

2) Non Rollover design

Reliable backstop cam design for excessive torque

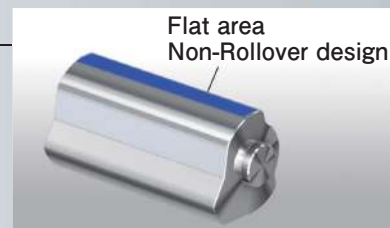

3) Lower speed lift-off

Perfect for intermediate shaft of gear reducer

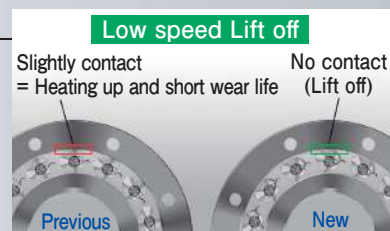



BR-HT Torque limiter model

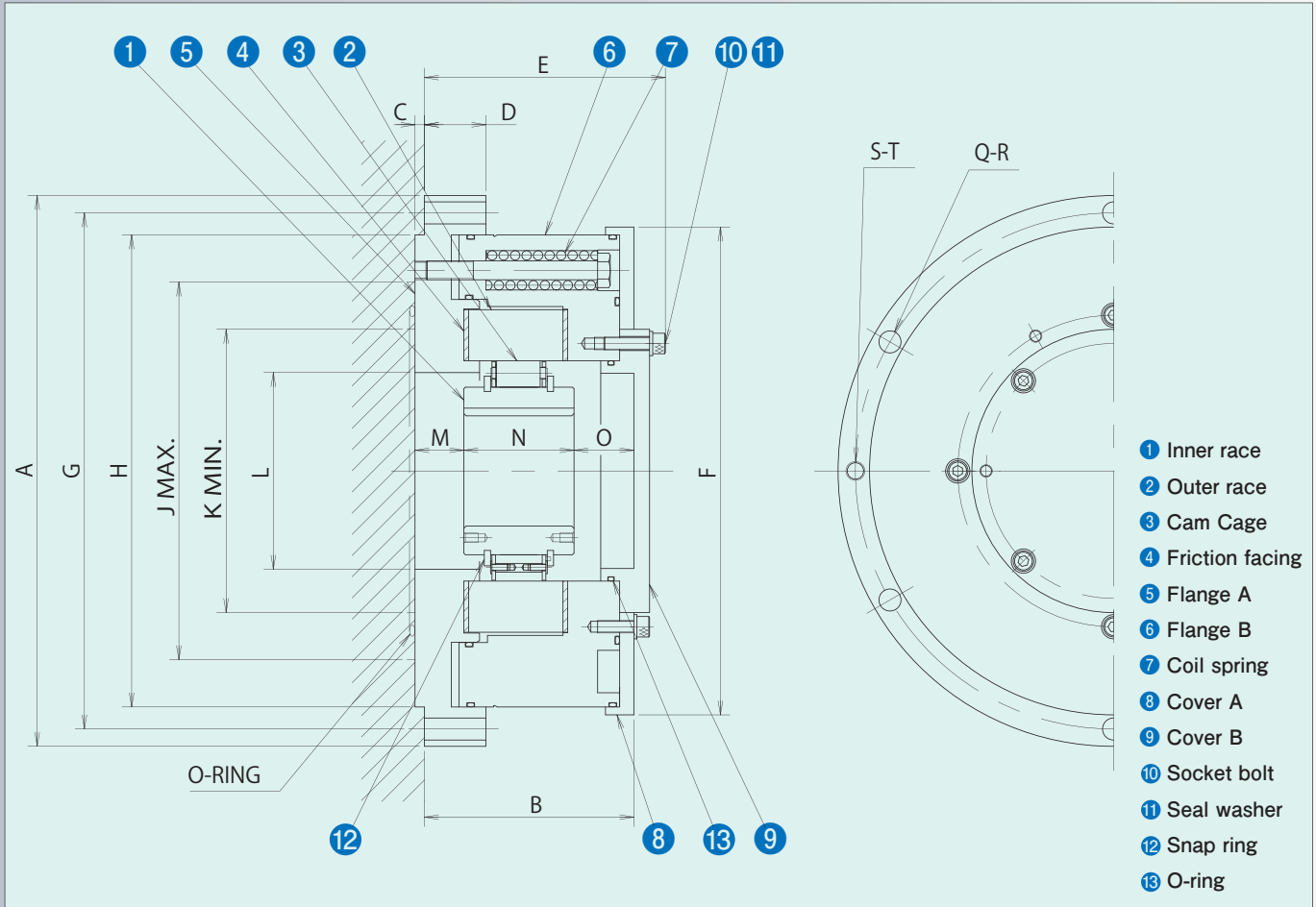

Torque limiter model

Dimensions in mm

Model name	Slipping torque (N·m)	Innerrace Overrunning Speed (r/min)		Max. bore mm	A	B	C	D	E	F	G	H(j6)	J	K	L	M	N	O	Q-R	S-T
		Min.	Max.																	
BR60HT-TL-B85A	1450	420	3600	65	330	127	6	37	143	295	308	280	215	165	110	29	60	43	6-14	2-M12
BR70HT-TL-B100A	2370	390	3600	80*	350	134	6	39	150	311	328	300	240	180	125	31	70	38	6-14	2-M12
BR80HT-TL-B120B	3500	310	3600	95	400	134	6	36	150	360	373	340	260	200	145	31	70	38	6-18	2-M16
BR90HT-TL-B140B	4640	300	3000	110	430	134	6	36	160	386	403	375	280	220	165	31	70	50	6-18	2-M16
BR95HT-TL-R170C	9270	240	2700	130	500	156	6	43	175	460	473	425	340	250	196	40	80	38	6-18	2-M16
BR98HT-TL-R200C	12800	230	2100	155	555	156	6	49	175	516	528	495	390	275	226	40	80	38	6-18	2-M16
BR180HT-TL-R240A	21800	220	1300	185	710	170	8	50	195	630	670	630	455	355	290	50	90	45	12-24	2-M20
BR190HT-TL-R260A	30900	200	1300	205	750	183	8	50	205	670	710	670	500	375	310	50	105	40	12-24	2-M20
BR220HT-TL-R290B	43800	195	1100	230	850	190	8	52	218	755	800	730	560	405	335	50	105	48	12-28	2-M24
BR230HT-TL-R310D	54600	185	1100	240	900	240	10	63	260	800	850	775	600	435	355	63	120	69	12-28	2-M24
BR260HT-TL-R360D	77200	170	1000	280	975	243	10	63	267	870	925	850	670	485	400	63	125	71	12-34	2-M30
BR300HT-TL-R410D	103000	165	1000	300	1060	243	10	63	267	950	1000	950	750	535	450	63	125	71	12-34	2-M30

Note : Keyway no mark on bore size...ISOR773/DIN6885.1
Keyway * mark on bore size...DIN6885.3

Model name

BR80HT-TL-B120B-90-3000

Slipping torque N·m
Bore size mm
Size and length of Cam A,B,C,D type
Torque limiter model
Model name
HT=High Torque

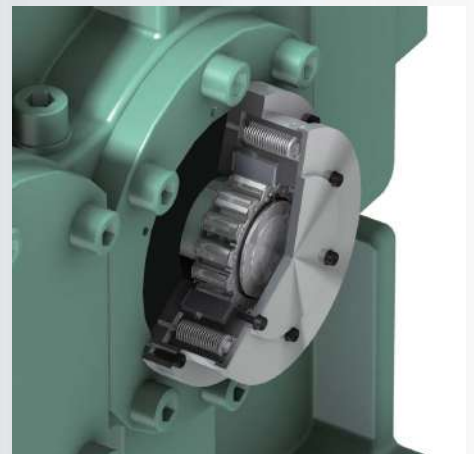

Installation example



BR-HT Tension release model

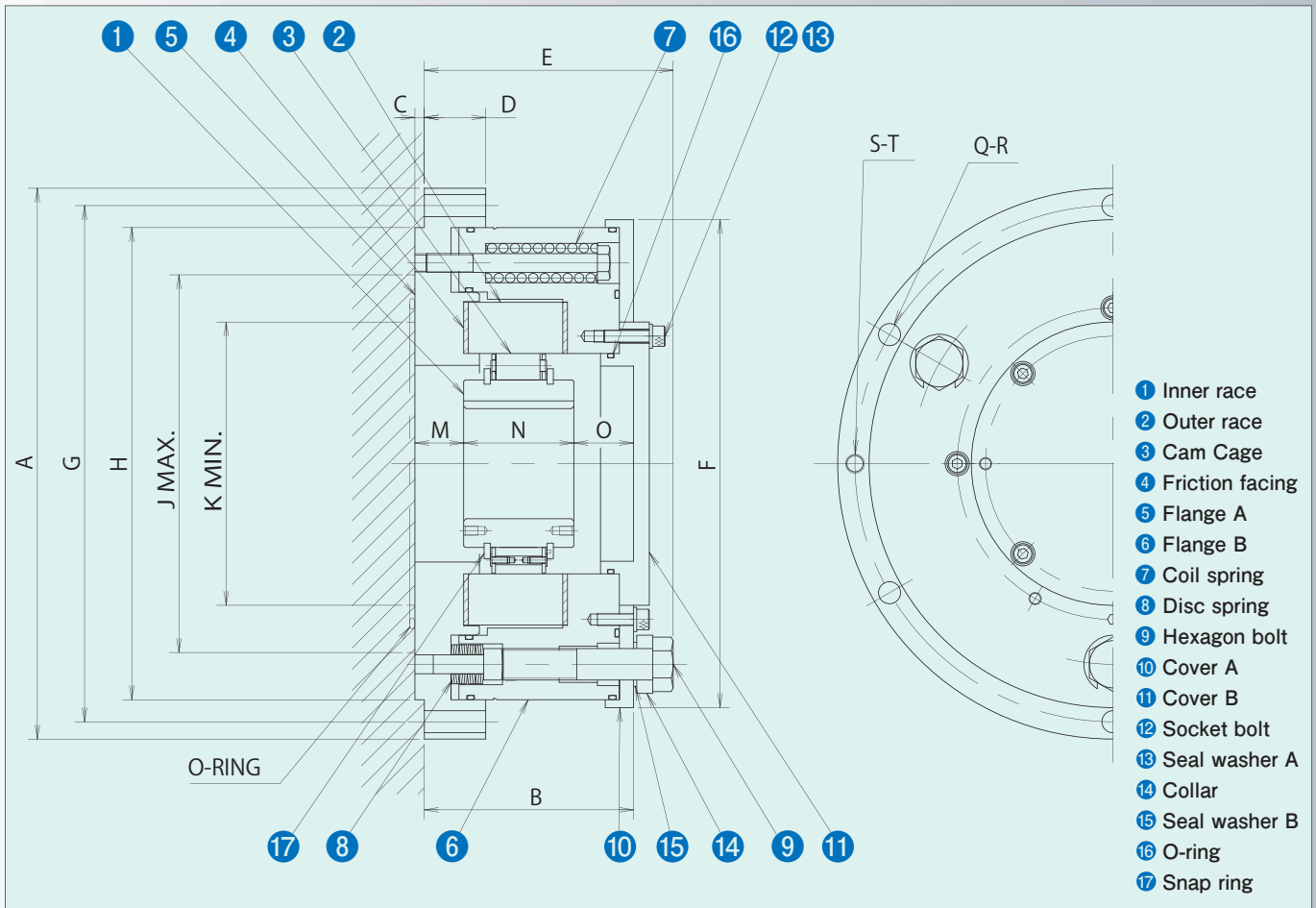

Tension release model

Dimensions in mm

Model name	Slipping torque (N · m)	Innerrace Overrunning Speed (r/min)		Max. bore mm	A	B	C	D	E	F	G	H(j6)	J	K	L	M	N	O	Q-R	S-T
		Min.	Max.																	
BR60HT-TR-B85A	1450	420	3600	65	330	127	6	37	148	295	308	280	215	165	110	29	60	43	6-14	2-M12
BR70HT-TR-B100A	2370	390	3600	80*	350	134	6	39	159	311	328	300	240	180	125	31	70	38	6-14	2-M12
BR80HT-TR-B120B	3500	310	3600	95	400	134	6	36	159	360	373	340	260	200	145	31	70	38	6-18	2-M16
BR90HT-TR-B140B	4640	300	3000	110	430	134	6	36	163	386	403	375	280	220	165	31	70	50	6-18	2-M16
BR95HT-TR-R170C	9270	240	2700	130	500	156	6	43	188	460	473	425	340	250	196	40	80	38	6-18	2-M16
BR98HT-TR-R200C	12800	230	2100	155	555	156	6	49	188	516	528	495	390	275	226	40	80	38	6-18	2-M16
BR180HT-TR-R240A	21800	220	1300	185	710	170	8	50	210	630	670	630	455	355	290	50	90	45	12-24	2-M20
BR190HT-TR-R260A	30900	200	1300	205	750	183	8	50	223	670	710	670	500	375	310	50	105	40	12-24	2-M20
BR220HT-TR-R290B	43800	195	1100	230	850	190	8	52	243	755	800	730	560	405	335	50	105	48	12-28	2-M24
BR230HT-TR-R310D	54600	185	1100	240	900	240	10	63	293	800	850	775	600	435	355	63	120	69	12-28	2-M24

Note : Keyway no mark on bore size...ISOR773/DIN6885.1
Keyway *mark on bore size...DIN6885.3

Model name

BR80HT-TR-B120B-90-3000

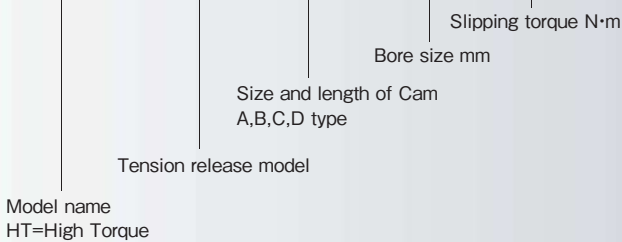

Installation example

Installation and usage

For details, see the manual supplied with the product.

- We recommend using shaft tolerances of h6 or h7 for Cam Clutch installation.
- Use ISO R773/DIN 6885.1 Parallel key or DIN6885.3. Ensure that the key does not move in the keyway. A loose key will damage the Cam Clutch.
- Resolve Socket bolts and Seal washers, and then remove the Cover B with O-ring.
- Total Indicator Reading (T.I.R.) does not exceed the value shown in right figure.
- Install Flange A to the housing prepared by the customer. The bolts connecting to Flange A must comply with a strength class of 8.8 or 10.9 and need torque tightening to the following table using a torque tightening wrench.
- The cams should be held in Lift-Off position to avoid cams rotating. You can do this by mounting an o-ring or similar on the outside of Cam cage.
- Install Inner race with Cam cage and Snap rings to Outer race and the shaft. O-ring or similar must be removed when Cam cage installs about half way to Flange B (refer to the right figure).
 - When installing Cam Clutch over the shaft, never strike the clutch with a steel hammer or apply unnecessary impact loads.
 - Verify Cam Clutch direction of rotation. The arrow on Inner race shows the free running (cam disengaged) direction. Make sure that the direction of cam engagement matches the intended application.
 - Tap Inner race lightly with a soft hammer moving around the race circumference so the Cam Clutch moves slowly and uniformly onto the end of the shaft.
- Place an end plate over Inner race and use the mounting bolts to pull Cam Clutch onto the shaft. Fix the end plate securely.
- Non-lubricated when delivered, please lubricate before use. To lubricate the Cam Clutch, apply lubricant at the outer circumference of Inner race. Avoid over lubrication, as it will cause the Cam Clutch to generate excessive heat.
- BR-HT-TL/TR Series accepts lubricant generally used in a gear reducer. It is possible to mount BR-HT-TL/TR directly in gearbox without separate lubrication. In case of gear oil, viscosity must be ISO VG 32 to 320.
- For the seal between Flange A and the housing provides an o-ring or sealant.
- Install Cover B with O-ring by Seal washer and Socket bolts.
- Check dimension X. Dimension X must not be smaller than the value X min. indicated on the name plate.

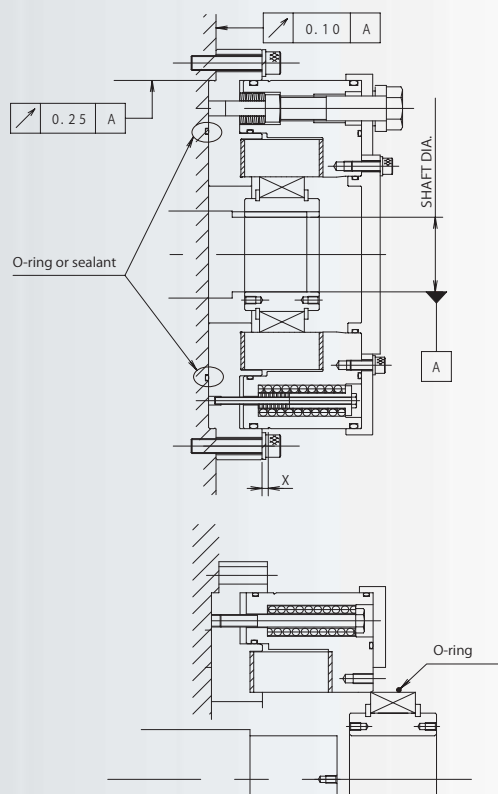

Model name	Bolt size	Tightening torque (N · m)	
		Strength Class 8.8	Strength Class 10.9
BR60HT-B85A-TL/TR	M12	84.3	118
BR70HT-B100A-TL/TR	M12	84.3	118
BR80HT-B120B-TL/TR	M16	206	289
BR90HT-B140B-TL/TR	M16	206	289
BR95HT-R170C-TL/TR	M16	206	289
BR98HT-R200C-TL/TR	M16	206	289
BR180HT-R240A-TL/TR	M20	402	568
BR190HT-R260A-TL/TR	M20	402	568
BR220HT-R290B-TL/TR	M24	696	980
BR230HT-R310D-TL/TR	M24	696	980
BR260HT-R360D-TL	M30	1420	1960
BR300HT-R410D-TL	M30	1420	1960

LUBRICATION

BR-HT-TL/TR Series Cam Clutch needs periodic maintenance and lubrication to provide maximum performance throughout their service life. Lack of the prescribed maintenance and lubrication will shorten the Cam Clutch's service life and may result in unnecessary mechanical damage. BR-HT-TL/TR Cam Clutch can be lubricated with oil or depending on the type of application.

The recommended oils are for operating environments ranging from -5°C to +40°C. Contact TSUBAKI when the environmental temperature is outside of this range.

Brand	Type
JX Nippon Oil and Energy	FBK Turbine 32, Automatic D2
Shell	Rimura D Oil 10W, Turbo Oil T32
Exxon Mobil	DTE Oil Light, ATF 220

Note: Crossover shipping of outer races with different colors may occur across the board, although performance and quality are unchanged.

Selection Procedure

1. To calculate the setting torque, please apply 20% higher than maximum backstopping torque per one clutch. Maximum backstopping torque should include overload conditions.
2. Select the proper clutch on page 3 or 4 which satisfies the calculated setting torque.
3. Check Innerrace overrunning speed and bore size.

FOR TENSION RELEASE MODEL BR-HT-TR

Tension release function releases the backstop. It is absolutely necessary to pay attention on these operations. When the load is left on a conveyor, it would reverse.

1. Releasing back stopping torque
 - (1) Make a match mark on Hexagon bolts and Cover A.
 - (2) Loosen the three Hexagon bolts until Collar is removed by hand. And remove Collar.
 - (3) Tighten the three Hexagon bolts until free resistance.
 - (4) Tightening the Hexagon bolts one by one approx. 60° at a time until backstopping torque starts releasing.
2. Operational Again
 - (1) Loosen the three Hexagon bolts one by one approx. 60° until not feel resistance.
 - (2) Install Collar between Bolt head and Seal washer.
 - (3) Tighten the three hexagon bolts until Collar is fixed.

Safety Guide



WARNING

This mark indicates a situation where incorrect handling may cause hazardous conditions, resulting in death or severe injury.

- Guards must be provided on all power transmission and conveyor applications in accordance with provisions of ANSI/ASME B 15.1 1992 and ANSI/ASME B 20.1 1993 or other applicable standards. When revisions of these standards are published, the updated edition shall apply.
 - When using any of the products described in this catalog, be sure to follow any applicable safety laws and regulations (such as the Labor Safety and Health Regulations).
 - Follow the instructions below when installing, maintaining, or inspecting a product.
 1. Turn the power switch off.
 2. Do not store the device under equipment that may fall.
 3. Secure the movable parts of the equipment so as not to move.
 4. Wear clothing and protective gear suitable for the work.
 - When performing a test operation or during periodic inspections, verify that the protective equipment is functioning properly.
 - Always lock out power switch before installing, removing, lubricating or servicing a system that uses Cam Clutch products.
 - If the Cam Clutch is used for repeated starting and stopping, make sure the strength of the supports for the Cam Clutch are sufficient.
 - The capacity of your Cam Clutch may be affected by the accuracy of its set up, the amount of pressure exerted on it, wear on other parts in your system, or wear life of the Cam Clutch itself. Check the Cam Clutch at regular intervals and take any necessary safety precautions.
 - When connecting or disconnecting Cam Clutch products, eye protection is required. Wear safety glasses, protective clothing, gloves and safety shoes.
 - Cam Clutch maintenance and inspection should be performed only by qualified personnel with specialized knowledge.
- Otherwise, fire, and injury may occur.**
- Operate the Cam Clutch according to the manufacturer's instructions.



CAUTION

This mark indicates a situation where incorrect handling may cause hazardous conditions, resulting in medium or slight personal injury or property damage.

- Ensure that the end user of the device receives the appropriate instruction manual. Also make sure that the contents of the manual are carefully read before use.
- In the event that an instruction manual is not available, use the device name and model number to request one from the distributor where you purchased the device or from our sales office.
- Do not rearrange the device's components or perform additional work in order to modify the device in any way.
- Periodically check the product's functions and operations according to the instruction manual. If a function or operation is found to be inadequate, contact the distributor for repair.
- When disposing of the device, treat it as industrial waste.
- The device details described in this catalog are intended primarily for model selection. Before using the device, read the instruction manual thoroughly, and ensure the device is used correctly.

Warranty: Tsubaki E&M Co.: hereinafter referred to as "Seller" Customer: hereinafter referred to as "Buyer"
Goods sold or supplied by Seller to Buyer: hereinafter referred to as "Goods"

1. Warranty period without charge

Effective 18 months from the date of shipment or 12 months from the first use of Goods, including the installation of the Goods to the Buyer's equipment or machine - whichever comes first.

2. Warranty coverage

Should any damage or problem with the Goods arise within the warranty period, given that the Goods were operated and maintained according to the instructions provided in the manual, the Seller will repair and replace at no charge once the Goods are returned to the Seller.

This warranty does not include the following:

- 1) Any costs related to removal of Goods from the Buyer's equipment or machine to repair or replace parts.
- 2) Cost to transport Buyer's equipment or machines to the Buyer's repair shop.
- 3) Costs to reimburse any profit loss due to any repair or damage and consequential losses caused by the Buyer.

3. Warranty with charge

Seller will charge for any investigation and repair of Goods caused by:

- 1) Improper installation by failing to follow the instruction manual.
- 2) Insufficient maintenance or improper operation by the Buyer.
- 3) Incorrect installation of the Goods to other equipment or machines.
- 4) Any modifications or alterations of Goods by the Buyer.
- 5) Any repair by engineers other than the Seller or those designated by the Seller.
- 6) Operation in an environment not specified in the manual.
- 7) Force Majeure or forces beyond the Seller's control such as natural disasters and injustices inflicted by a third party.
- 8) Secondary damage or problems incurred by the Buyer's equipment or machines.
- 9) Defective parts supplied or specified by the Buyer.
- 10) Incorrect wiring or parameter settings by the Buyer.
- 11) The end of life cycle of the Goods under normal usage.
- 12) Losses or damages not liable to the Seller.

4. Dispatch service

The service to dispatch a Seller's engineer to investigate, adjust or trial test the Seller's Goods is at the Buyer's expense.

The logos and product names used in this catalog are either trademarks or registered trademarks of Tsubakimoto Chain Co. or the Tsubaki Group in Japan and other countries.



TSUBAKIMOTO CHAIN CO.

Headquarters

Nakanoshima Mitsui Building
3-3-3 Nakanoshima, Kita-ku
Osaka, 530-0005, Japan
Phone : +81-6-6441-0011
URL : <http://tsubakimoto.com>

Chain & Power Transmission Sales

1-3 Kannabidai, 1-chome
Kyotanabe,
Kyoto, 610-0380, Japan
Phone : +81-774-64-5022

Group companies

NORTH and SOUTH AMERICA

U.S. TSUBAKI POWER TRANSMISSION, LLC
301 E. Marquardt Drive, Wheeling, IL 60090, U.S.A.
Phone : +1-847-459-9500
URL : <http://ustsubaki.com/>

TSUBAKI of CANADA LIMITED
1630 Drew Road, Mississauga, Ontario, L5S 1J6, Canada
Phone : +1-905-676-0400
URL : <http://tsubaki.ca>

TSUBAKI BRASIL EQUIPAMENTOS INDUSTRIAIS LTDA.
R. Pamplona, 1018, C.J. 73/74, Jd. Paulista
CEP 01405-001, São Paulo, S.P. Brazil
Phone : +55-11-3253-5656
URL : <http://tsubaki.ind.br>

EUROPE

TSUBAKIMOTO EUROPE B.V.
Aventurijn 1200, 3316 LB Dordrecht, The Netherlands
Phone : +31-78-620-4000
URL : <http://tsubaki.eu>

TSUBAKIMOTO U.K. LTD
Osier Drive, Sherwood Park, Annesley, Nottingham
NG15 0DX, United Kingdom
Phone : +44-1623-688-700
URL : <http://tsubaki.eu>

TSUBAKI DEUTSCHLAND GmbH
ASTO Park Oberpfaffenhofen, Friedrichshafener Straße 1
D-82205, Gilching, Germany
Phone : +49-8105-7307100
URL : <http://tsubaki.de/>

OOO "TSUBAKI KABELSCHLEPP"
Prospekt Andropova 18, Building 6
115432 Moscow, Russia
Phone : +7-499-418212
URL : <http://kabelschlepp.ru/>

ASIA and OCEANIA

TAIWAN TSUBAKIMOTO CO.
No. 33, Lane 17, Zhiciang North Road
Gueishan Township Taoyuan County Taiwan R.O.C.
Phone : +886-3-3293827/8/9
URL : <http://tsubakimoto.com.tw>

TSUBAKIMOTO CHAIN (SHANGHAI) CO. LTD.
Room 601, Urban City Centre, 45 Nanchang Road
Huangpu District, Shanghai 2000020, People's Republic of China
Phone : +86-21-5396-6651/2
URL : <http://tsubaki.cn/>

TSUBAKI INDIA POWER TRANSMISSION PVT. LTD.
Chandrika Chambers No.4, 3rd Floor, Anthony Street
Royapettah, Chennai, Tamil Nadu 600014, India
Phone : +91-44-4231-5251
URL : <http://tsubaki.in/>

TSUBAKIMOTO SINGAPORE PTE. LTD.
25 Gul Lane, Jurong, Singapore 629419
Phone : +65-6861-0422/3/4
URL : <http://tsubaki.sg>

TSUBAKIMOTO SINGAPORE PTE. LTD.
VIETNAM REPRESENTATIVE OFFICE
H&H Building 8F, 209 Hoàng Văn Thụ
Phú Nhuận District, Hồ Chí Minh City, Vietnam
Phone : +84-8-3999-0131/2
URL : <http://tsubaki.net.vn/>

PT. TSUBAKI INDONESIA TRADING
Wisma 46 - Kota BNI, 24th Floor, Suite 24.15
Jl. Jend. Sudirman, Kav. 1, Jakarta 10220, Indonesia
Phone : +62-21-571-4230/31
URL : <http://tsubakimoto.co.id/>

TSUBAKI POWER TRANSMISSION (MALAYSIA) SDN. BHD.
No. 22, Jalan Astaka U8/84A,
Bukit Jelutong Industrial Park
Section U8, 40150 Shah Alam, Selangor, Malaysia
Phone : +60-3-7859-8585
URL : <http://tsubaki.sg>

TSUBAKI AUSTRALIA PTY. LTD.
Unit E, 95-101 Silverwater Road
Silverwater NSW 2128, Australia
Phone : +61-02-9704-2500
URL : <http://tsubaki.com.au>

TSUBAKI AUSTRALIA PTY. LTD.
NEW ZEALAND BRANCH
2 Kalmia Street, Ellerslie, Auckland 1051, New Zealand
Phone : +64-275-082-726
Phone : <http://tsubaki.com.au>

TSUBAKIMOTO (THAILAND) CO. LTD.
388 Exchange Tower, 19th Floor Unit 1902
Sukhumvit Road, Klongtoey, Bangkok 10110, Thailand
Phone : +66-2-262-0667/8/9
URL : <http://tsubaki.co.th>

TSUBAKIMOTO KOREA CO., LTD.
#1004/1005 East Wing, Hanshin Intervalley 24, 707-34
Yeoksam-dong, Gangnam-gu, Seoul, Korea
Phone : +82-02-2183-0311
URL : <http://tsubakimoto.com>



The Tsubaki Eco Link logo is used only on products that satisfy the standards for environmental friendliness set by the Tsubaki Group.

Distributed by: