



Backstop Size Selection for Conveyor Drive Applications



BACKSTOP Mounting Arrangements

Preventing reverse rotation of inclined or vertical conveyor systems is one of the most common applications for Backstops. There are many configurations of conveyor systems that employ backstops. This paper presents the most common types and provides examples and calculations needed to properly size the backstop in order to maximize performance and improve safety of the conveying system.

Single and Dual Drives

Backstops for low speed overrunning applications are installed directly on the extended head shaft, as shown in Figure 1 and 2. TSUBAKI® recommends single installation of the Backstop to prevent reverse rotation of head shaft.

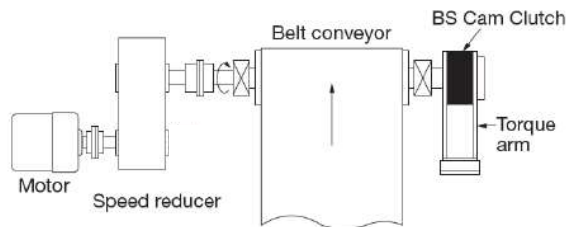

Figure 1

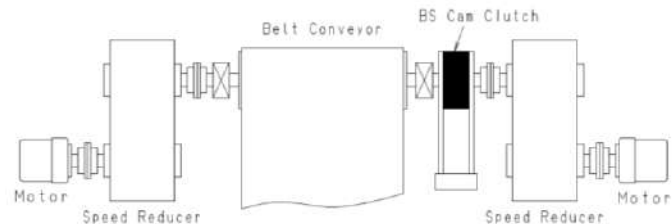

Figure 2

Tandem Drives

When the conveyor arrangement calls for a primary and secondary drive, as shown in Figure 3, the Backstop on the primary drive unit holds the full load. The Backstop on the secondary drive unit holds the back tension from the belt. It keeps belt traction on both conveyor systems.

TSUBAKI® recommends that the Backstop, having torque capacity that is equal to the sum of the primary and secondary motors, be installed on the primary drive unit.

The Backstop on the secondary drive unit should be sized from the secondary drive motor only.

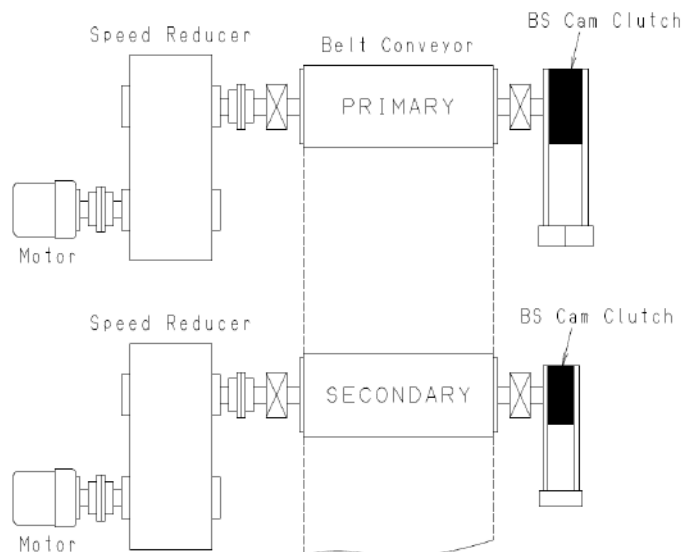

Figure 3

BACKSTOP Size Selection

[Service Factor]

Backstops by definition are required to hold back a load from moving in a reverse direction. Care must be taken in calculating the torque requirements and should be based on maximum or worst case conditions and not average/normal loads. Because any failure of a backstop might result in costly damages or injury, care must be exercised by considering all the possible loads and, in turn selecting appropriate service factors. The Backstop needs to be sized for the breakdown or stalled torque of the drive motors. The following table shows typical service factors that should be applied when size selecting backstops.

Motor Stalled Torque = Motor maximum torque experienced with no shaft rotation

Maximum Stalled Torque or Breakdown torque % of Normal Motor Rating	Service Factor
175%	1.17
200%	1.33
250%	1.67
300%	2.00

[Load sharing]

Backstops have no backlash, therefore, two backstops can theoretically share 50% of the total calculated torque. However, we have to consider “load sharing factors.”

Dual Drive Application

In a dual drive application with a single head shaft, if the required backstop capacity is in excess of the listed capacity in the catalogue, a twin arrangement of Backstop Cam Clutch is the solution, as shown in Figure 4. And we have to consider “load sharing factor.”

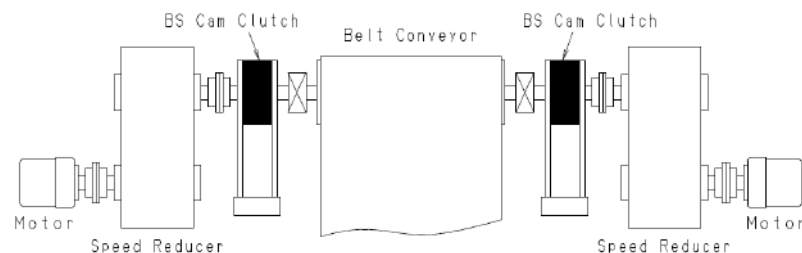

Figure 4

Note: In this usage, load sharing factor becomes 1.7 for two Backstop Cam Clutches, not 2.

Example of Backstop Size Selection

[Example No.1: Single Drive/ Single Backstop]

Application information:

Drive motor – 125 HP

Head shaft – 43.75 RPM

Shaft Dia. – 6.00"

250% stalled torque motor – 1.67 SF

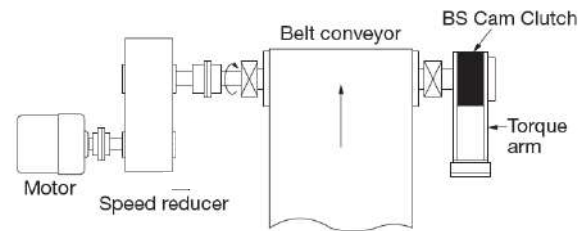

Selection:

$125 \text{ HP} \times 5250 \times 1.67 \text{ SF} / 43.75 \text{ RPM} = 25,050 \text{ FT.LBS.}$

Backstop size = BS160HS (Bore range: 3.94 to 6.25")

Torque capacity of BS160HS = 28,912 FT.LBS. > 25,050 FT.LBS.

[Example No.2: Dual Drive/ Single Backstop]

Application information:

Drive motor – 2 X 400 HP

Head shaft – 29.17 RPM

Shaft Dia. – 11.25"

200% stalled torque motor – 1.33 SF

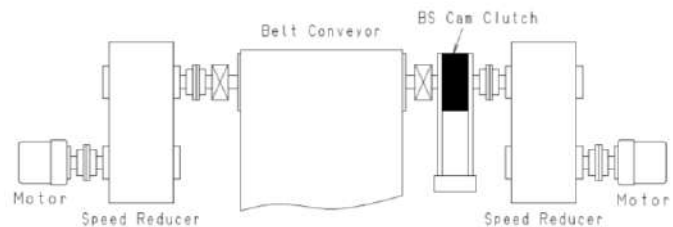

Selection:

$2 \times 400 \text{ HP} \times 5250 \times 1.33 \text{ SF} / 29.17 \text{ RPM} = 191,498 \text{ FT.LBS.}$

Backstop size = BS300HS (Bore range: 9.00 to 11.75")

Torque capacity of BS300HS = 216,843 FT.LBS. > 191,498 FT.LBS.

[Example No.3: Dual Drive/ Dual Backstop]

Application information:

Drive motor – 2 X 1000 HP

Head shaft – 31.82 RPM

Shaft Dia. – 13.5"

200% stalled torque motor – 1.33 SF

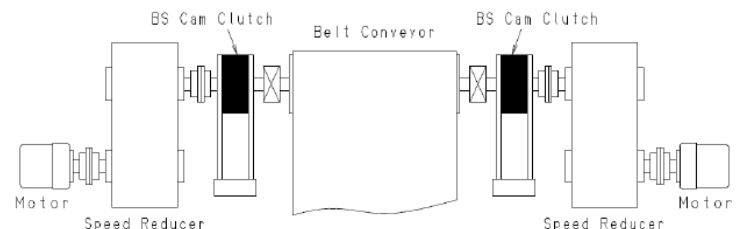

Selection:

$2 \times 1000 \text{ HP} \times 5250 \times 1.33 \text{ SF} / 31.82 \text{ RPM} = 438,875 \text{ FT.LBS.}$

Correction torque = $438,875 / 1.7 = 258,162 \text{ FT.LBS.}$

Backstop size = BS350HS X 2 pcs (Bore range: 9.88 to 13.73")

Torque capacity of BS350HS = 289,124 FT.LBS. > 258,162 FT.LBS.

[Example No.4: Tandem Drive/ Tandem Backstop]

Application information:

Primary drive motor – 750 HP

Secondary drive motor – 750 HP

Head shaft – 38.89 RPM

200% stalled torque motor – 1.33 SF

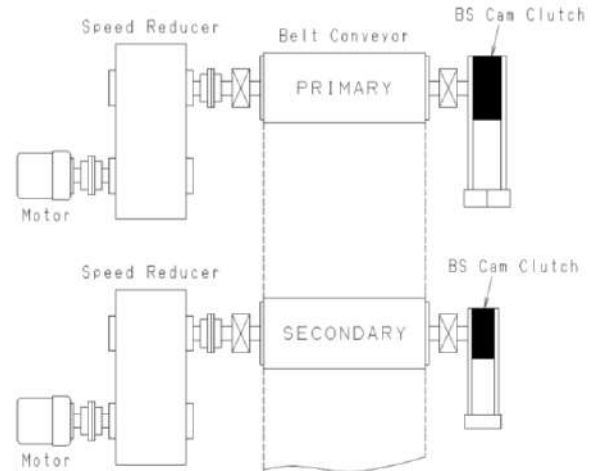

Selection (Primary Backstop):

$2 \times 750 \text{ HP} \times 5250 \times 1.33 \text{ SF} / 38.89 \text{ RPM} = 269,317 \text{ FT.LBS.}$

Backstop size = BS350HS (Bore range: 9.88 to 13.73")

Torque capacity of BS350HS = 289,124 FT.LBS. > 269,317 FT.LBS.

Selection (Secondary Backstop):

$750 \text{ HP} \times 5250 \times 1.33 \text{ SF} / 38.89 \text{ RPM} = 134,658 \text{ FT.LBS.}$

Backstop size = BS270HS (Bore range: 7.875 to 10.625")

Torque capacity of BS270HS = 150,462 FT.LBS. > 134,658 FT.LBS.

[Example No.5: Dual Tandem Drive/ Dual tandem Backstop]

Application information:

Primary drive motor – 2 X 1500 HP
 Secondary drive motor – 2 X 1500 HP
 Head shaft – 35 RPM
 175% stalled torque motor – 1.17 SF

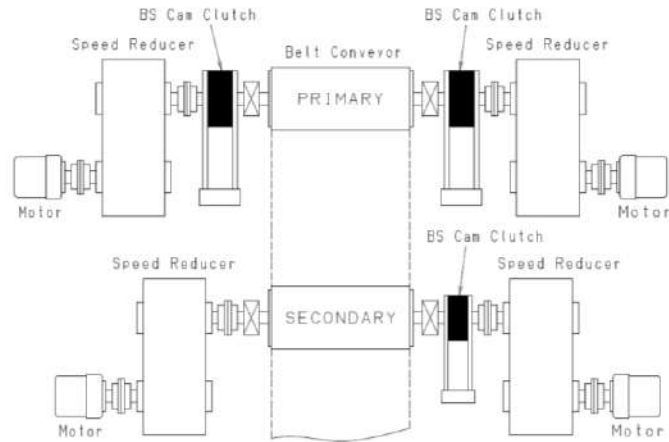

Selection (Primary Backstop):

$4 \times 1500 \text{ HP} \times 5250 \times 1.17 \text{ SF} / 35 \text{ RPM} = 1,053,000 \text{ FT.LBS.}$
 Correction torque = $1,053,000 / 1.7 = 619,412 \text{ FT.LBS.}$
 Backstop size = BS450HS X 2 (Bore range: 13.75 to 17.625")
 Torque capacity of BS450HS = 722,809 FT.LBS. > 619,412 FT.LBS.

Selection (Secondary Backstop):

$2 \times 1500 \text{ HP} \times 5250 \times 1.17 \text{ SF} / 35 \text{ RPM} = 526,500 \text{ FT.LBS.}$
 Backstop size = BS425HS (Bore range: 12.75 to 16.625")
 Torque capacity of BS425HS = 542,107 FT.LBS > 526,500 FT.LBS.



U.S. Tsubaki Power Transmission, LLC
 (800) 323-7790
www.ustsubaki.com