

# TSUBAKI Heavy Duty Drive Chains & Sprockets



## Philosophy

One hundred years of fundamental technology, and the endless pursuit of new value.

Tsubakimoto Chain has worked tirelessly on improving chain performance since our founding in 1917. We were the first Japanese factory to be accredited by Japan Industrial Standards (JIS) for roller chain in 1953. We dubbed that roller chain our first generation chain, and every decade since we have made major leaps in performance up to the 2006 launch of our G7 Series, the world's highest quality roller chain. To celebrate our 100th anniversary, we will be launching our next generation G8 Series, the next evolution of our chain line.

### History of RS Roller Chain

- 1917 • Founding
- 1953 • 612 Series JIS accredited
- 1964 • NA Series 2x kW ratings
- 1969 • 53 Series 15% higher tensile strength, global quality
- 1976 • 60 Series 7% higher tensile strength, 25% higher kW ratings, world's top quality
- 1985 • 70 Series 2x wear life, less initial elongation
- 1995 • 80 Series M-type connecting link provides 25% higher kW ratings, 30% increased wear life
- 2006 • G7 Series 33% increased kW ratings, 2x wear life
- 2009 • G7-EX Series Expanded G7 size range
- 2016 • **G8 Series Centennial model**

As a manufacturing company, Tsubakimoto Chain continues to develop products that adapt to global needs with a century of chain manufacturing know-how and contribute to energy savings, labor savings, and better efficiency around the world.

### Leonardo da Vinci, founder of the roller chain (1452–1519)

Leonardo da Vinci, the genius of the Renaissance, devised the prototype of a roller chain that today is widely used as a drive chain. His foresight and advanced ideas are revealed in his notebooks, which contain sketches of an object that looks remarkably like a modern chain. The photo shows a portrait of da Vinci, made entirely out of link plates, on display in the main lobby of Tsubakimoto Chain's Kyotanabe Plant.

# The Start of a New Era



100th Anniversary Model

## TSUBAKI G8 SERIES



The rebirth of the drive chain,  
with improved quality and performance.

### PRODUCT MAP

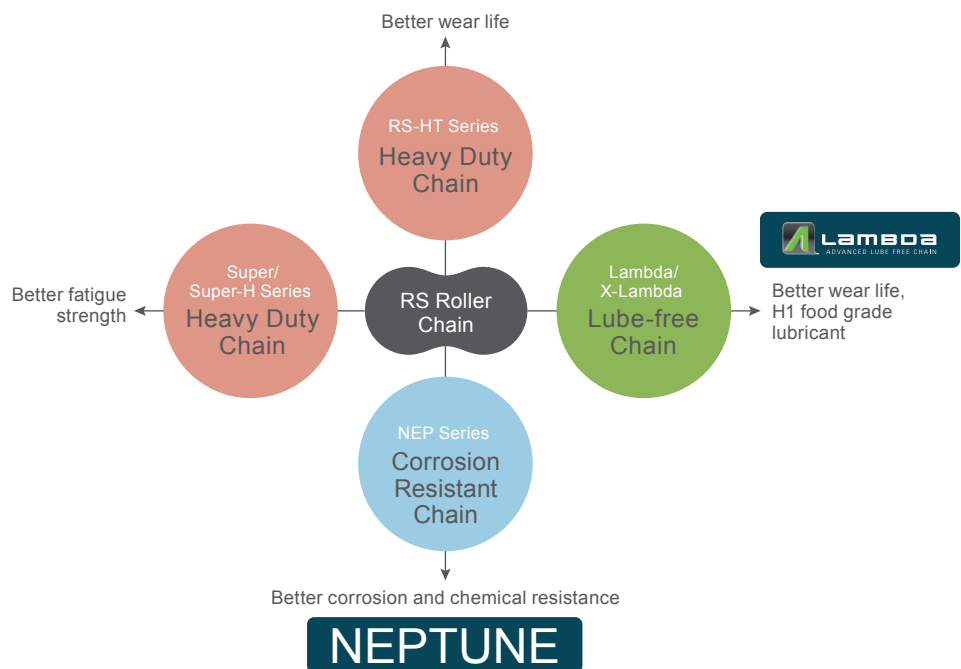

# The Ultimate in Strength



## Super Chain

**5–10% higher maximum allowable load than the previous series!**

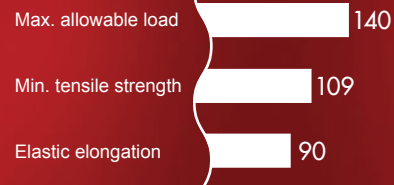

Note: With RS Roller Chain as benchmark (100).

■ Available sizes: RS80–RS240, up to sextuple strand

## RS-HT Chain

**Twice the wear life of the previous series!**

**Slip fit connecting links now available!**

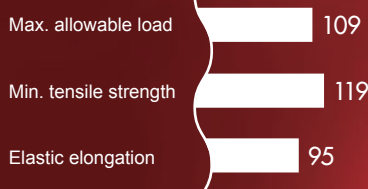

Note: With RS Roller Chain as benchmark (100).

■ Available sizes: RS60–RS240, up to triple strand

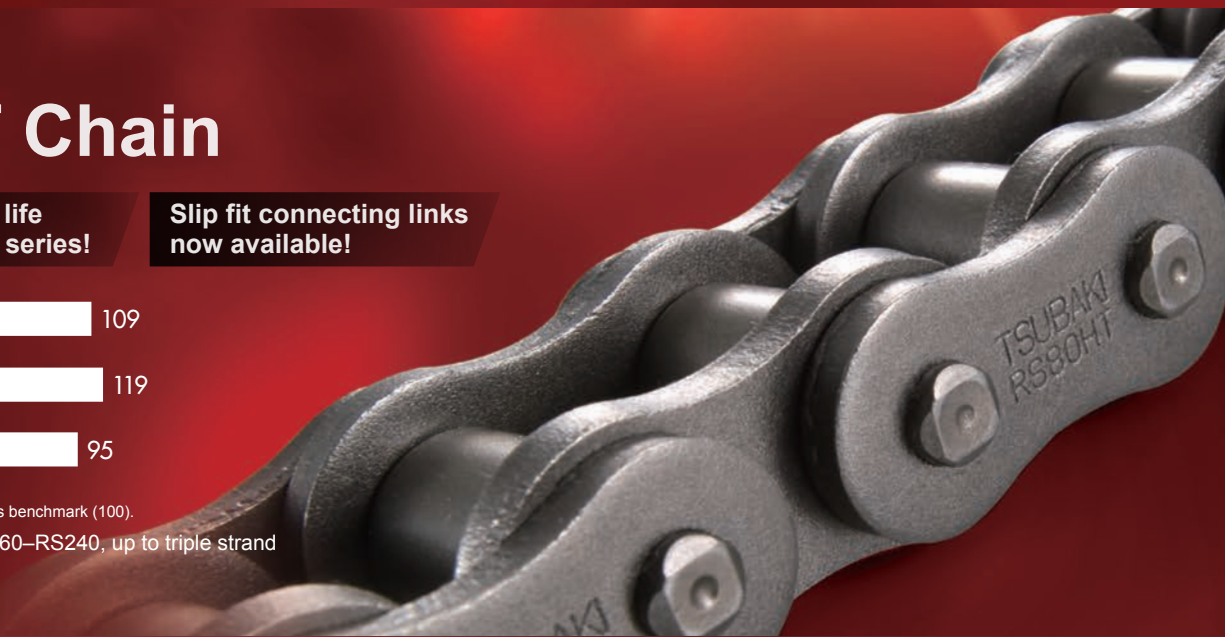

## Super-H Chain

**20% higher max. allowable load than the previous series!**

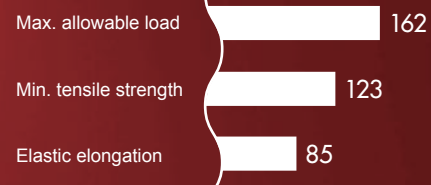

Note: With RS Roller Chain as benchmark (100).

■ Available sizes: RS80–RS240, up to triple strand



# The pursuit of higher performance has helped us create a stronger, longer lasting chain. Choose the model that best suits your needs.

Heavy Duty Drive Chain has a higher maximum allowable load and higher minimum tensile strength than standard RS Roller Chain.

## ● Comparison of min. tensile strengths and max. allowable loads

Note: With RS Roller Chain min. tensile strength and max. allowable load as benchmark (100).

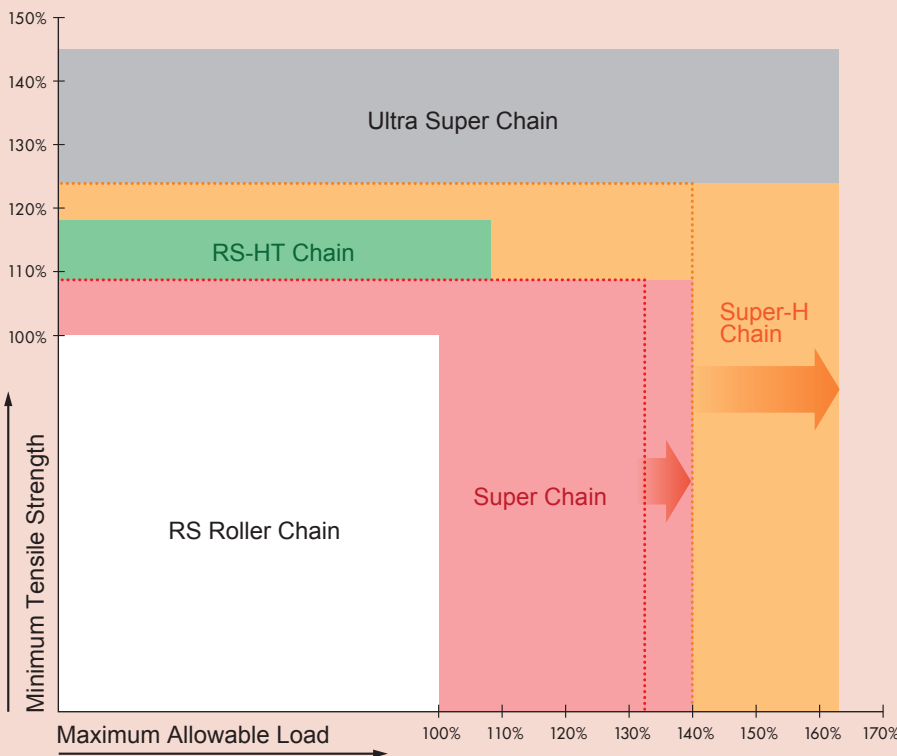
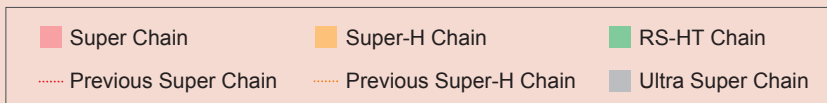

### Minimum Tensile Strength

Five or more links of a roller chain are attached to jigs on either side (as shown in the image below) and then pulled until breakage. This test is conducted numerous times, and the minimum value statistically derived is the minimum tensile strength. Any roller chain, attached to jigs on either side and then pulled until breakage, that breaks at a load lower than the minimum tensile strength is considered non-conforming.

#### Tensile strength test

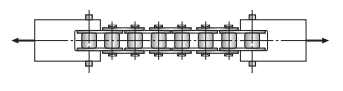

#### Relationship between test results and min. tensile strength

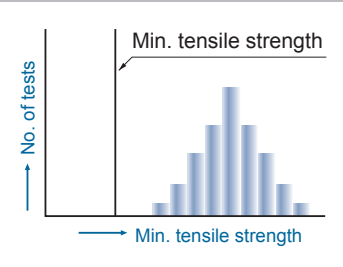

### Max. Allowable Load & Fatigue Strength

A roller chain's maximum allowable load is the lower limit of its fatigue strength (except for stainless steel chains). A roller chain will not suffer fatigue breakage at a load lower than this value, even if the load is repeatedly applied.

#### Concept of Fatigue Load

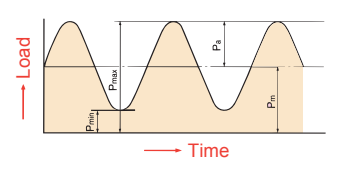

### Chain Numbering Example

**Super Chain**

[Base chain]  
**RS80 - SUP - 1 - M**  
 Super Chain | F: Press fit connecting link | M: Slip fit connecting link

[With connecting link]  
**RS80 - SUP - 1 - FJL**  
 F: Press fit connecting link | M: Slip fit connecting link

**RS-HT Chain**

[Base chain]  
**RS80 - HT - 1 - M**  
 RS-HT Chain | Blank: Press fit connecting link | M: Slip fit connecting link

[With connecting link]  
**RS80 - HT - 1 - JL**  
 JL: Press fit connecting link | MJL: Slip fit connecting link

**Super-H Chain**

[Base chain]  
**RS80 - SUP - H - 1**  
 Super-H Chain

[With connecting link]  
**RS80 - SUP - H - 1 - JL**  
 Press fit connecting link



Super-H Chain

# Heavy Duty Chains provide the following benefits.

For example...

RS80-SUP-H-1 Super-H Chain has the same maximum allowable load as RS80-2-RP RS Roller Chain. So, you can replace double strand RS Roller Chain with single strand Super-H Chain, saving you space.

Super-H Chain



**RS80-SUP-H-1**

Max. Allowable Load **25.0kN**

Double strand RS Roller Chain



**RS80-2-RP**

Max. Allowable Load **25.0kN**

**A smaller chain means a smaller sprocket.**

RS Sprocket (for single strand chains)

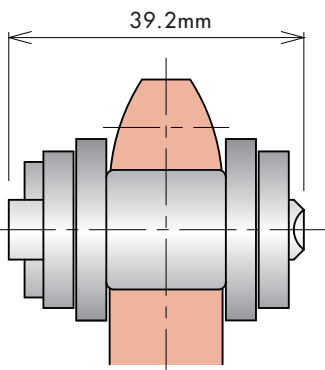

RS Sprocket (for double strand chains)

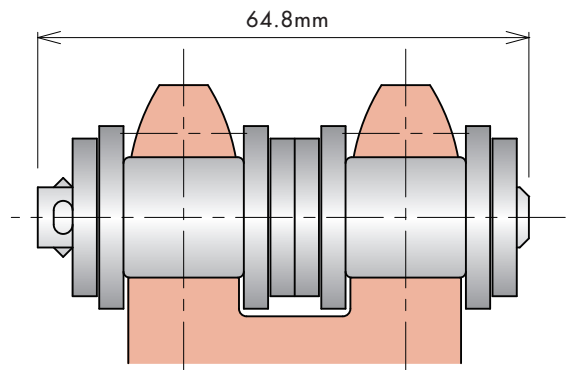

**A small chain and sprocket means more compact parts for your equipment!**

Motors, frames, etc.

# You can reduce costs by using smaller chains and sprockets.

## Cost Comparison

Note: With total costs of double strand RS Roller Chain as benchmark (100).

	Super-H Chain	Double Strand RS Roller Chain
Chain	<b>28</b>	<b>33</b>
Small sprocket	<b>5</b>	<b>19</b>
Large sprocket	<b>17</b>	<b>48</b>
Total	<b>50</b>	<b>100</b>

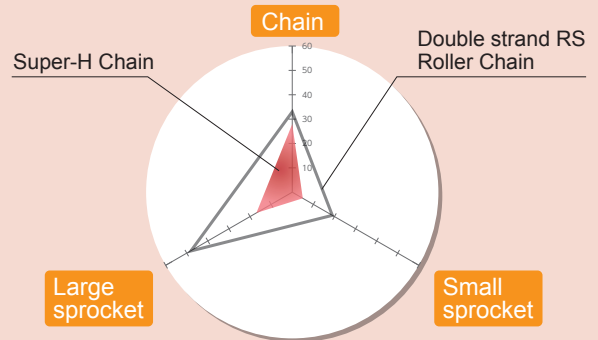

## Selection Conditions

Chain size: RS80 Center distance between shafts: 800mm Small sprocket: 18T Large sprocket: 36T

**Reduce costs 50% with the chain and sprocket**

## Notes from the Developer



I extensively reviewed all the past specifications in making the G8 Series Heavy Duty Chain. Especially, our main goal with the Super-H Chain was finding a way to somehow improve fatigue strength without changing the chain's basic dimensions. I reviewed how each component was formed, but one key point was adding Tsubaki's original, patented ring coining\* to the inner link plates. This creates plastic deformation around the link plate holes, which maintains the precision of the plate holes and in turn influences the chain's quality and performance. In changing the formation methods we also introduced new equipment that could provide a product with better performance and reliability. Check out Tsubaki's new G8 Series Heavy Duty Drive Chain to see how it can help make your equipment more compact and reduce initial costs.



\*Ring coining creates an area of plastic deformation around the link plate hole, thereby creating residual stress.

Item \ Chain	Super Chain	RS-HT Chain	Super-H Chain
Features	<ul style="list-style-type: none"> <li>● High kW ratings</li> <li>● High shock absorption properties</li> <li>● Users can go one size down from RS Roller Chain</li> </ul>	<ul style="list-style-type: none"> <li>● High kW ratings</li> <li>● High tensile strength</li> <li>● High shock absorption properties</li> </ul>	<ul style="list-style-type: none"> <li>● High fatigue strength</li> <li>● High tensile strength</li> <li>● High shock absorption properties</li> <li>● Same max. allowable load as double strand RS Roller Chain</li> </ul>
Offset links	<ul style="list-style-type: none"> <li>● Can use 4POL with single strand chains only.</li> </ul>	<ul style="list-style-type: none"> <li>● No offset links available. Use an even number of links.</li> </ul>	
Sprockets	<ul style="list-style-type: none"> <li>● Can use RS Roller Chain sprockets in single and multi strand configurations.</li> </ul>	<ul style="list-style-type: none"> <li>● Can use RS Roller Chain sprockets in single strand configurations.</li> <li>● Cannot use RS Roller Chain sprockets with multi strand configurations for RS-HT and Super-H chains.</li> </ul>	
	<ul style="list-style-type: none"> <li>● Quench harden the small sprocket teeth.</li> <li>● Use a carbon steel sprocket with a rating of S35C or higher.</li> <li>● Tsubaki provides Tough Tooth sprockets ideal for use with Heavy Duty Chain. See pages 17–18 of this catalog for more information.</li> </ul>		

# Applications

## Transfer Cranes

Rubber tire drive

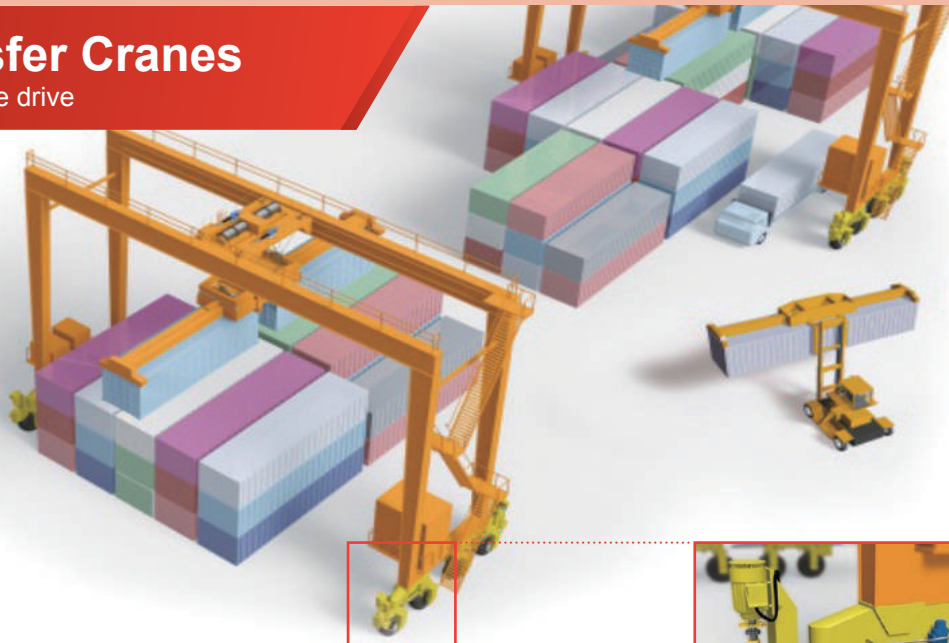

Chain used → Super Chain

Reason → High kW ratings



## Looper

Stage lifter

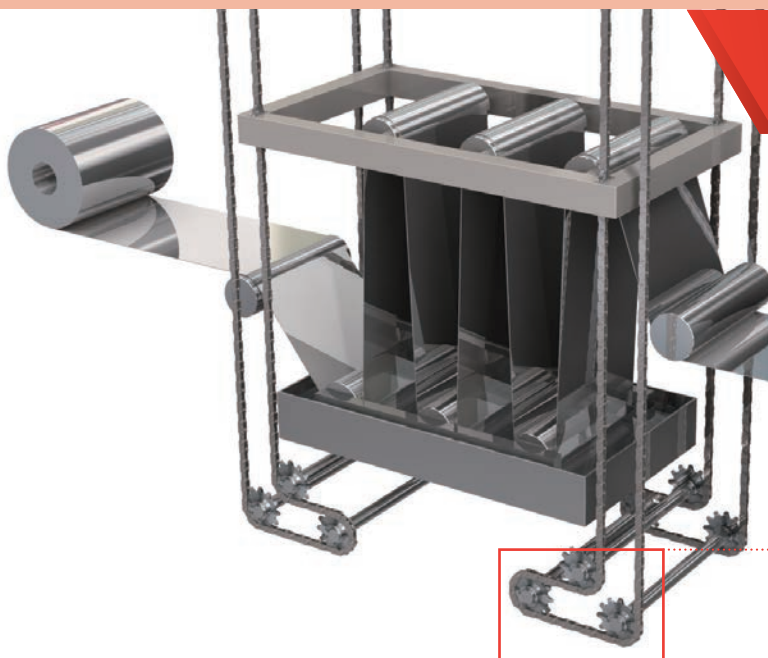

Chain used → Super-H Chain

Reason → High minimum tensile strength





## Wobbler Feeder

Roller drive



Chain used

Super Chain

Reason

High kW ratings  
High shock load resistance

## Cultivator

Rotary drive



Chain used

Super-H Chain

Reason

High kW ratings  
Space saving

# Super Chain

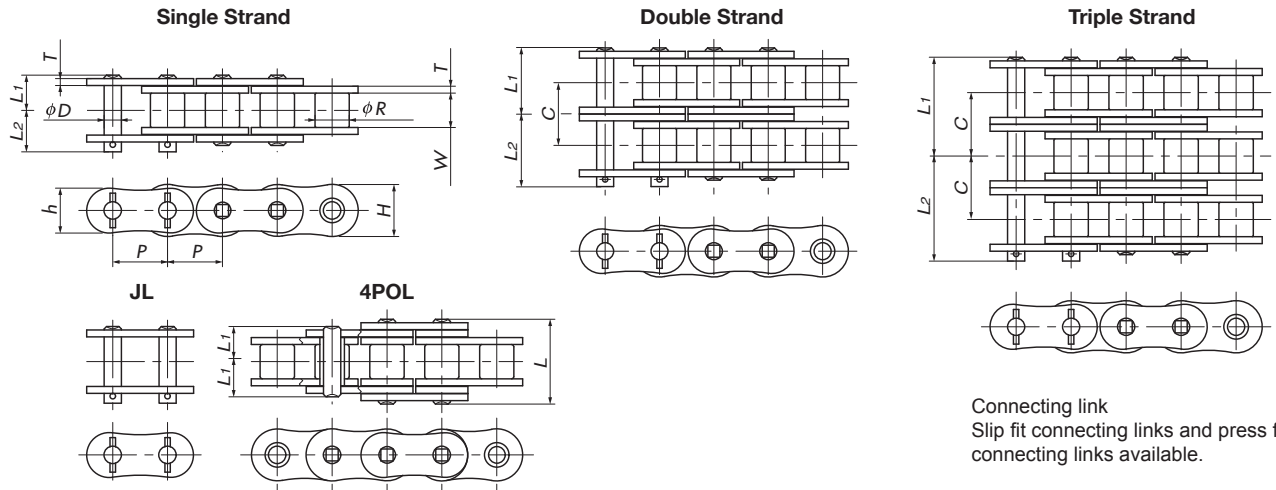

TSUBAKI Chain Number	Pitch P	Roller Diameter R	Inner Width of Inner Link W	Plates			Pin Diameter D	4-Pitch Offset Link Pin Length L
				Thickness T	Height H	Height h		
RS80-SUP-1 RS80-SUP-2 RS80-SUP-3	25.40	15.88	15.88	3.2	24.1	20.8	7.94	39.3
RS100-SUP-1 RS100-SUP-2 RS100-SUP-3	31.75	19.05	19.05	4.0	30.1	26.0	9.54	48.0
RS120-SUP-1 RS120-SUP-2 RS120-SUP-3	38.10	22.23	25.40	4.8	36.2	31.2	11.11	59.9
RS140-SUP-1 RS140-SUP-2 RS140-SUP-3	44.45	25.40	25.40	5.6	42.2	36.4	12.71	65.7
RS160-SUP-1 RS160-SUP-2 RS160-SUP-3	50.80	28.58	31.75	6.4	48.2	41.6	14.29	77.2
RS180-SUP-1 RS180-SUP-2 RS180-SUP-3	57.15	35.71	35.72	7.15	54.2	46.8	17.46	86.4
RS200-SUP-1 RS200-SUP-2 RS200-SUP-3	63.50	39.68	38.10	8.0	60.3	52.0	19.85	94.9
RS240-SUP-1 RS240-SUP-2 RS240-SUP-3	76.20	47.63	47.63	9.5	72.4	62.4	23.81	116.0

TSUBAKI Chain Number	No. of Strands	Pin Length L1+L2	Dimensions L1	Dimensions L2	Transverse Pitch C	Minimum Tensile Strength kN{kgf}	Average Tensile Strength kN{kgf}	Maximum Allowable Load kN{kgf}	Approximate Mass kg/m	Links per Unit
RS80-SUP-1	1	35.5	16.25	19.25	29.3	74.2 { 7570 }	85.3 { 8700 }	20.1 { 2050 }	2.81	120
RS80-SUP-2	2	64.8	30.9	33.9		148 { 15140 }	171 { 17400 }	34.2 { 3490 }	5.62	
RS80-SUP-3	3	94.1	45.6	48.5		223 { 22710 }	256 { 26100 }	50.3 { 5130 }	8.40	
RS100-SUP-1	1	42.6	19.75	22.85	35.8	111 { 11300 }	127 { 13000 }	32.4 { 3300 }	4.25	96
RS100-SUP-2	2	78.5	37.7	40.8		222 { 22600 }	255 { 26000 }	55.0 { 5610 }	8.38	
RS100-SUP-3	3	114.4	55.65	58.75		332 { 33900 }	382 { 39000 }	80.9 { 8250 }	12.57	
RS120-SUP-1	1	53.8	24.9	28.9	45.4	162 { 16500 }	186 { 19000 }	42.2 { 4300 }	6.3	80
RS120-SUP-2	2	99.2	47.6	51.6		324 { 33000 }	373 { 38000 }	71.7 { 7310 }	12.44	
RS120-SUP-3	3	144.8	70.4	74.4		485 { 49500 }	559 { 57000 }	105 { 10750 }	18.64	
RS140-SUP-1	1	58.6	26.9	31.7	48.9	213 { 21700 }	245 { 25000 }	56.9 { 5800 }	8.04	68
RS140-SUP-2	2	107.5	51.35	56.15		426 { 43400 }	490 { 50000 }	96.7 { 9860 }	15.92	
RS140-SUP-3	3	156.6	75.85	80.75		638 { 65100 }	735 { 75000 }	142 { 14500 }	23.84	
RS160-SUP-1	1	68.7	31.85	36.85	58.5	273 { 27800 }	314 { 32000 }	73.5 { 7500 }	10.79	60
RS160-SUP-2	2	127.3	61.15	66.15		545 { 55600 }	628 { 64000 }	125 { 12750 }	21.43	
RS160-SUP-3	3	185.9	90.45	95.45		818 { 83400 }	941 { 96000 }	184 { 18750 }	32.10	
RS180-SUP-1	1	78.1	35.65	42.45	65.8	358 { 36500 }	412 { 42000 }	85.7 { 8740 }	14.23	54
RS180-SUP-2	2	144.1	68.75	75.35		716 { 73000 }	824 { 84000 }	146 { 14860 }	28.08	
RS180-SUP-3	3	210.2	101.7	108.5		1070 { 109500 }	1240 { 126000 }	214 { 21850 }	40.56	
RS200-SUP-1	1	83.8	39.0	44.8	71.6	439 { 44800 }	505 { 51500 }	100 { 10200 }	17.63	48
RS200-SUP-2	2	155.5	74.85	80.65		879 { 89600 }	1010 { 103000 }	170 { 17340 }	34.91	
RS200-SUP-3	3	227.2	110.75	116.45		1320 { 134400 }	1520 { 154500 }	250 { 25500 }	52.44	
RS240-SUP-1	1	103.4	47.9	55.5	87.8	639 { 65200 }	735 { 75000 }	139 { 14200 }	25.63	40
RS240-SUP-2	2	191.3	91.9	99.4		1280 { 130400 }	1470 { 150000 }	237 { 24140 }	50.88	
RS240-SUP-3	3	279.0	135.85	143.15		1920 { 195600 }	2210 { 225000 }	348 { 35500 }	76.11	

Note: 1. Pins are riveted.  
 2. Four-pitch offset links (4POL) available for single strand only.  
 3. Maximum allowable load when using a four-pitch offset link (4POL) is 90% that of the above values.



# Kilowatt Ratings Tables RS160-SUP - RS240-SUP

■ RS160-SUP-1 Kilowatt Ratings Table  
(kW Ratings for Single Strand Chain)

Small Sprocket No. or Pitch lubrication type	Small Sprocket Max rpm											
	10	25	50	100	150	200	250	300	350	400	450	
	A II	B	C									
13	7.89	18.0	33.6	62.7	90.3	117	129	129	129			
14	8.55	19.5	36.4	67.9	97.8	127	145	145	145			
15	9.21	21.0	39.2	73.1	105	136	160	160	160			
16	9.87	22.5	42.0	78.4	113	146	177	177	177			
17	10.5	24.0	44.9	83.7	121	156	191	193	193			
18	11.2	25.6	47.7	89.1	128	166	203	207	207			
19	11.8	27.1	50.6	94.4	136	176	215	219	219			
20	12.4	28.7	53.5	99.8	144	186	228	232	232			
21	13.1	30.2	56.4	105	152	196	240	244	244			
22	13.7	31.8	59.3	111	159	206	252	257	257			
23	14.3	33.3	62.2	116	167	217	265	270	270			
24	14.9	34.9	65.1	122	175	227	277	282	282			
25	15.6	36.5	68.1	127	183	237	290	295	295			
26	16.2	38.0	71.0	132	191	247	302	308	308			
28	17.4	41.2	76.9	144	207	268	327	343	343	343		
30	18.7	44.4	82.9	155	223	289	353	380	380	380		
32	19.9	47.6	88.8	166	239	309	378	419	419	419		
35	21.8	52.4	97.9	183	263	341	417	472	472	472		
40	24.9	60.6	113	211	304	394	481	545	545	545		
45	28.0	68.8	128	240	345	447	547	619	619	619		

■ RS180-SUP-1 Kilowatt Ratings Table  
(kW Ratings for Single Strand Chain)

Small Sprocket No. or Pitch lubrication type	Small Sprocket Max rpm									
	10	25	50	100	150	200	250	300	350	400
	A II	B	C							
13	10.3	23.6	44.1	82.2	118	153	173	173	173	
14	11.2	25.6	47.7	89.1	128	166	187	187	187	
15	12.1	27.6	51.4	95.9	138	179	202	202	202	
16	13.0	29.5	55.1	103	148	192	216	216	216	
17	13.8	31.5	58.9	110	158	205	231	231	231	
18	14.7	33.5	62.6	117	168	218	245	245	245	
19	15.5	35.6	66.4	124	178	231	260	260	260	
20	16.3	37.6	70.2	131	189	244	275	275	275	
21	17.1	39.6	73.9	138	199	257	290	290	290	
22	18.0	41.7	77.8	145	209	271	305	305	305	
23	18.8	43.7	81.6	152	219	284	320	320	320	
24	19.6	45.8	85.4	159	230	297	335	335	335	
25	20.4	47.8	89.3	167	240	311	350	350	350	
26	21.2	49.9	93.1	174	250	324	365	365	365	
28	22.9	54.1	101	188	271	351	429	446	446	446
30	24.5	58.2	109	203	292	378	463	481	481	481
32	26.1	62.5	117	217	313	406	496	515	515	515
35	28.6	68.8	128	240	345	447	546	568	568	568
40	32.7	79.5	148	277	399	516	631	656	656	656
45	36.7	90.3	168	314	453	586	717	745	745	745

■ RS200-SUP-1 Kilowatt Ratings Table  
(kW Ratings for Single Strand Chain)

Small Sprocket No. or Pitch lubrication type	Small Sprocket Max rpm												
	10	15	20	30	40	50	70	100	150	200	250	300	350
	A II	B	C										
13	13.4	19.3	25.0	36.1	46.7	57.1	77.3	107	154	194	194	194	194
14	14.5	20.9	27.1	39.1	50.6	61.9	83.8	115	166	211	211	211	211
15	15.7	22.6	29.2	42.1	54.5	66.7	90.2	124	179	232	234	234	234
16	16.8	24.2	31.3	45.1	58.5	71.5	96.8	133	192	249	258	258	258
17	17.9	25.8	33.5	48.2	62.4	76.3	103	142	205	266	283	283	283
18	19.1	27.5	35.6	51.3	66.4	81.2	110	151	218	283	308	308	308
19	20.1	29.1	37.7	54.3	70.4	86.0	116	161	231	300	334	334	334
20	21.2	30.8	39.9	57.4	74.4	91.0	123	170	244	317	355	355	355
21	22.2	32.4	42.0	60.5	78.4	95.9	130	179	258	334	374	374	374
22	23.3	34.1	44.2	63.7	82.5	101	136	188	271	351	393	393	393
23	24.3	35.8	46.4	66.8	86.5	106	143	197	284	368	412	412	412
24	25.4	37.5	48.5	69.9	90.6	111	150	207	298	386	432	432	432
25	26.5	39.2	50.7	73.1	94.7	116	157	216	311	403	451	451	451
26	27.5	40.9	52.9	76.2	98.8	121	163	225	325	420	471	471	471

■ RS240-SUP-1 Kilowatt Ratings Table  
(kW Ratings for Single Strand Chain)

Small Sprocket No. or Pitch lubrication type	Small Sprocket Max rpm																
	5	10	15	20	25	30	40	50	60	80	100	125	150	175	200	250	300
	A II	B	C														
13	11.5	22.4	32.2	41.8	51.1	60.2	77.9	95.3	112	145	178	217	256	276	276	276	276
14	12.4	24.2	34.9	45.2	55.3	65.2	84.4	103	122	158	193	235	277	308	308	308	308
15	13.2	26.1	37.6	48.7	59.6	70.2	91.0	111	131	170	207	254	299	341	341	341	341
16	14.1	28.0	40.3	52.3	63.9	75.3	97.5	119	140	182	222	272	320	368	376	376	376
17	15.0	29.9	43.1	55.8	68.2	80.4	104	127	150	194	238	290	342	393	412	412	412
18	15.9	31.8	45.8	59.4	72.6	85.5	111	135	160	207	253	309	364	418	449	449	449
19	16.8	33.5	48.6	62.9	76.9	90.6	117	144	169	219	268	327	386	443	483	483	483
20	17.7	35.3	51.3	66.5	81.3	95.8	124	152	179	232	283	346	408	468	510	510	510
21	18.5	37.1	54.1	70.1	85.7	101	131	160	188	244	298	365	430	494	538	538	538
22	19.4	38.8	56.9	73.7	90.1	106	138	168	198	257	314	384	452	519	565	565	565
23	20.3	40.6	59.7	77.3	94.5	111	144	176	208	269	329	402	474	545	593	593	593
24	21.2	42.4	62.5	81.0	99.0	117	151	185	218	282	345	421	497	570	621	621	621
25	22.1	44.1	65.3	84.6	104	122	158	193	227	295	360	440	519	596	649	649	649
26	22.9	45.9	68.2	88.3	108	127	165	201	237	307	376	459	541	622	677	677	677

Note: 1. Use RS Roller Chains in the high speed range.  
2. Maximum allowable load when using a four-pitch offset link (4POL) is 90% that of the above values.

Multi Strand Factor	No. of chain strands	Multi strand factor					Lubrication Method	Lubrication Method		
		2	3	4	5	6		A II	B	C
		1.7	2.5	3.3	3.9	4.6	Drip lubrication	Oil bath or slinger disc lubrication	Forced pump lubrication	

Note: See the Tsubaki Drive Chains & Sprockets catalog for more information.

# RS-HT Chain

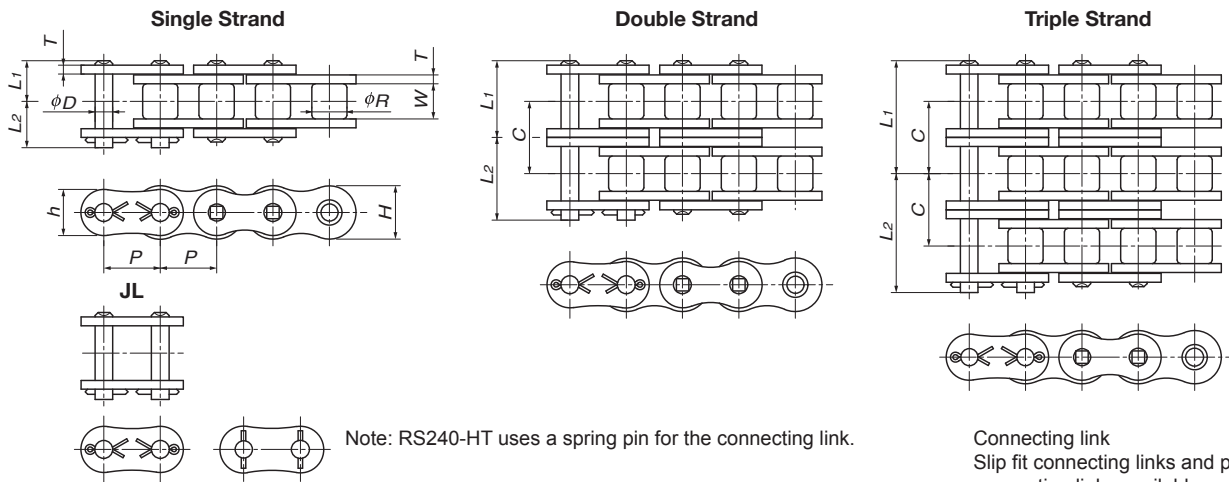

Note: RS240-HT uses a spring pin for the connecting link.

Connecting link  
Slip fit connecting links and press fit connecting links available.

TSUBAKI Chain Number	Pitch <i>P</i>	Roller Diameter <i>R</i>	Inner Width of Inner Link <i>W</i>	Plates			Pin Diameter <i>D</i>
				Thickness <i>T</i>	Height <i>H</i>	Height <i>h</i>	
RS60-HT-1 RS60-HT-2 RS60-HT-3	19.05	11.91	12.70	3.2	18.1	15.6	5.96
RS80-HT-1 RS80-HT-2 RS80-HT-3	25.40	15.88	15.88	4.0	24.1	20.8	7.94
RS100-HT-1 RS100-HT-2 RS100-HT-3	31.75	19.05	19.05	4.8	30.1	26.0	9.54
RS120-HT-1 RS120-HT-2 RS120-HT-3	38.10	22.23	25.40	5.6	36.2	31.2	11.11
RS140-HT-1 RS140-HT-2 RS140-HT-3	44.45	25.40	25.40	6.4	42.2	36.4	12.71
RS160-HT-1 RS160-HT-2 RS160-HT-3	50.80	28.58	31.75	7.15	48.2	41.6	14.29
RS200-HT-1 RS200-HT-2 RS200-HT-3	63.50	39.68	38.10	9.5	60.3	52.0	19.85
RS240-HT-1 RS240-HT-2 RS240-HT-3	76.20	47.63	47.63	12.7	72.4	62.4	23.81

TSUBAKI Chain Number	Number of Strands	Dimensions <i>L</i> <sub>1</sub>	Dimensions <i>L</i> <sub>2</sub>	Transverse Pitch <i>C</i>	Minimum Tensile Strength kN{kgf}	Average Tensile Strength kN{kgf}	Maximum Allowable Load kN{kgf}	Approximate Mass kg/m	Links per Unit
RS60-HT-1	1	14.8	17.0	26.1	48.1 { 4900 }	55.9 { 5700 }	9.81 { 1000 }	1.80	160
RS60-HT-2	2	27.8	29.9		96.1 { 9800 }	112 { 11400 }	16.7 { 1700 }	3.59	
RS60-HT-3	3	40.85	42.95		144 { 14700 }	168 { 17100 }	24.5 { 2500 }	5.36	
RS80-HT-1	1	18.3	20.9	32.6	81.4 { 8300 }	93.2 { 9500 }	16.2 { 1650 }	3.11	120
RS80-HT-2	2	34.6	37.2		163 { 16600 }	186 { 19000 }	27.6 { 2810 }	6.18	
RS80-HT-3	3	50.95	53.55		244 { 24900 }	279 { 28500 }	40.5 { 4130 }	9.24	
RS100-HT-1	1	21.8	24.5	39.1	124 { 12600 }	142 { 14500 }	24.5 { 2500 }	4.58	96
RS100-HT-2	2	41.4	44.1		247 { 25200 }	284 { 29000 }	41.7 { 4250 }	9.03	
RS100-HT-3	3	61.0	63.6		371 { 37800 }	427 { 43500 }	61.3 { 6250 }	13.54	
RS120-HT-1	1	26.95	30.55	48.9	167 { 17000 }	191 { 19500 }	32.4 { 3300 }	6.53	80
RS120-HT-2	2	51.4	55.0		333 { 34000 }	382 { 39000 }	55.0 { 5610 }	12.90	
RS120-HT-3	3	75.9	79.4		500 { 51000 }	574 { 58500 }	80.9 { 8250 }	19.33	
RS140-HT-1	1	28.9	33.1	52.2	218 { 22200 }	250 { 25500 }	42.7 { 4350 }	8.27	68
RS140-HT-2	2	55.0	59.5		435 { 44400 }	500 { 51000 }	72.6 { 7400 }	16.38	
RS140-HT-3	3	81.15	85.25		653 { 66600 }	750 { 76500 }	107 { 10880 }	24.54	
RS160-HT-1	1	33.95	38.45	61.9	278 { 28300 }	319 { 32500 }	55.9 { 5700 }	10.97	60
RS160-HT-2	2	64.9	69.6		555 { 56600 }	638 { 65000 }	95 { 9690 }	21.78	
RS160-HT-3	3	95.95	100.45		833 { 84900 }	956 { 97500 }	140 { 14250 }	32.63	
RS200-HT-1	1	42.9	48.1	78.3	486 { 49600 }	559 { 57000 }	78.5 { 8000 }	18.41	48
RS200-HT-2	2	82.05	87.3		973 { 99200 }	1120 { 114000 }	133 { 13600 }	36.47	
RS200-HT-3	3	121.25	126.55		1460 { 148800 }	1680 { 171000 }	196 { 20000 }	54.77	
RS240-HT-1	1	54.8	62.3	101.2	768 { 78300 }	883 { 90000 }	113 { 11500 }	29.13	40
RS240-HT-2	2	105.3	112.9		1540 { 156600 }	1770 { 180000 }	192 { 19550 }	57.35	
RS240-HT-3	3	156.05	163.55		2300 { 234900 }	2650 { 270000 }	282 { 28750 }	85.47	

Note: 1. No offset links available.  
2. Made-to-order product.





# Super-H Chain

Single Strand

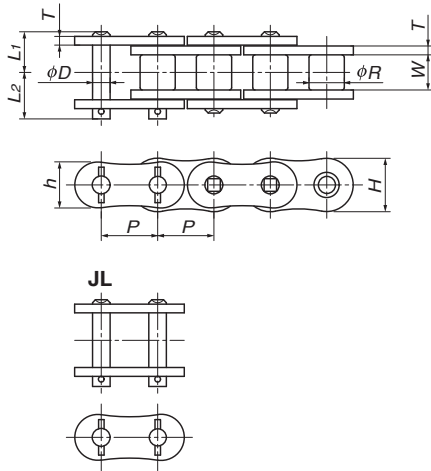

Double Strand

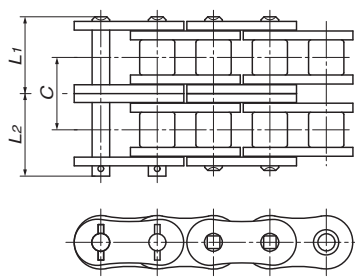

Triple Strand

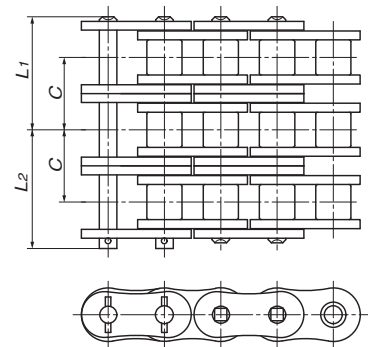

TSUBAKI Chain Number	No. of Strands	Pitch P	Roller Diameter R	Inner Width of Inner Link W	Plates			Pin			Transverse Pitch C	Minimum Tensile Strength kN {kgf}	Average Tensile Strength kN {kgf}	Maximum Allowable Load kN {kgf}	Approx. Mass kg/m
					Thickness T	Height H	Height h	Diameter D	L1	L2					
RS80-SUP-H-1	1											85.3 { 8700}	98.1 { 10000}	25.0 { 2550}	3.29
RS80-SUP-H-2	2	25.40	15.88	15.88	4.0	24.1	20.8	7.94	34.6	37.2	32.6	171 { 17400}	196 { 20000}	42.0 { 4280}	6.52
RS80-SUP-H-3	3								50.95	53.55		256 { 26100}	294 { 30000}	61.8 { 6300}	9.75
RS100-SUP-H-1	1								21.8	24.5		127 { 12900}	145 { 14800}	39.2 { 4000}	4.88
RS100-SUP-H-2	2	31.75	19.05	19.05	4.8	30.1	26.0	9.54	41.4	44.1	39.1	253 { 25800}	290 { 29600}	66.7 { 6800}	9.51
RS100-SUP-H-3	3								61.0	63.6		380 { 38700}	435 { 44400}	98.1 { 10000}	14.14
RS120-SUP-H-1	1								26.95	30.55		171 { 17400}	196 { 20000}	53.9 { 5500}	6.94
RS120-SUP-H-2	2	38.10	22.23	25.40	5.6	36.2	31.2	11.11	51.4	55.0	48.9	341 { 34800}	392 { 40000}	91.7 { 9350}	13.51
RS120-SUP-H-3	3								75.9	79.4		512 { 52200}	588 { 60000}	135 { 13750}	20.09
RS140-SUP-H-1	1								28.9	33.1		222 { 22600}	255 { 26000}	68.4 { 6970}	8.88
RS140-SUP-H-2	2	44.45	25.40	25.40	6.4	42.2	36.4	12.71	55.0	59.5	52.2	443 { 45200}	510 { 52000}	108 { 11050}	17.38
RS140-SUP-H-3	3								81.15	85.25		665 { 67800}	765 { 78000}	159 { 16250}	25.88
RS160-SUP-H-1	1								33.95	38.45		281 { 28700}	324 { 33000}	90.0 { 9180}	11.72
RS160-SUP-H-2	2	50.80	28.58	31.75	7.15	48.2	41.6	14.29	64.9	69.6	61.9	563 { 57400}	647 { 66000}	145 { 14790}	22.97
RS160-SUP-H-3	3								95.95	100.45		844 { 86100}	971 { 99000}	213 { 21750}	34.22
RS200-SUP-H-1	1								42.9	48.1		520 { 53000}	598 { 61000}	122 { 12410}	19.68
RS200-SUP-H-2	2	63.50	39.68	38.10	9.5	60.3	52.0	19.85	82.05	87.3	78.3	1040 { 106000}	1200 { 122000}	183 { 18700}	38.48
RS200-SUP-H-3	3								121.25	126.55		1560 { 159000}	1790 { 183000}	270 { 27500}	57.29
RS240-SUP-H-1	1								54.8	62.3		802 { 81800}	922 { 94000}	168 { 17170}	30.47
RS240-SUP-H-2	2	76.20	47.63	47.63	12.7	72.4	62.4	23.81	105.3	112.9	101.2	1600 { 163600}	1840 { 188000}	257 { 26180}	59.77
RS240-SUP-H-3	3								156.05	163.55		2410 { 245400}	2770 { 282000}	378 { 38500}	89.09

Note: Made-to-order product.

TSUBAKI Chain Number	RS80-SUP-H	RS100-SUP-H	RS120-SUP-H	RS140-SUP-H	RS160-SUP-H	RS200-SUP-H	RS240-SUP-H
Links per Unit	120	96	80	68	60	48	40

## Notes for use

- Select chains and sprockets as per the Allowable Load Selection Method.
- Offset links are not available due to the super heavy-duty nature of transmission. Use an even number of links.
- Use drip lubrication, oil bath or splash lubrication, or forced pump lubrication.
- RS Roller Chain sprockets can only be used with single strand chains. Cast iron sprockets cannot be used. Use sprockets made of S35C or higher carbon steel. Quench harden the teeth on sprockets with small numbers of teeth. Check key strength, etc.



# Ultra Super Roller Chain

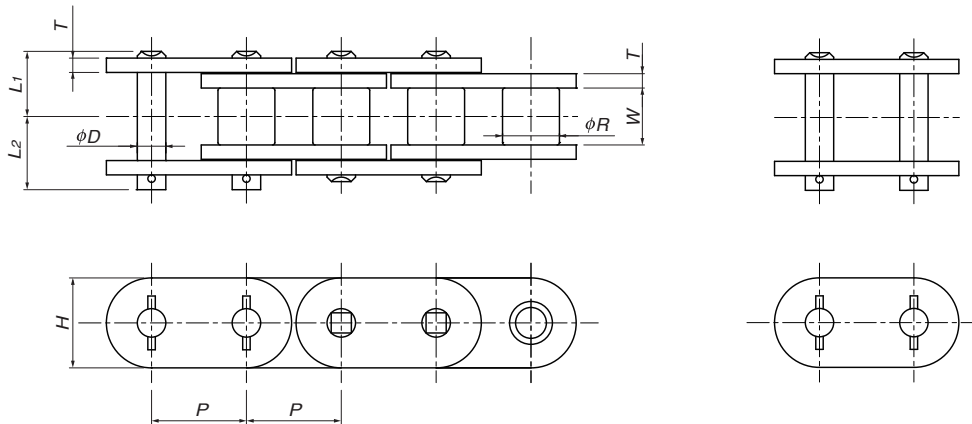

TSUBAKI Chain Number	Pitch $P$	Roller Diameter $R$	Inner Width of Inner Link $W$	Plates		Pins			Minimum Tensile Strength kN{kgf}	Maximum Allowable Load kN{kgf}	Approximate Mass kg/m	
				Thickness $T$	Width $H$	Diameter $D$	$L_1+L_2$	$L_1$				$L_2$
RF100-US-1	31.75	19.05	19.05	4.8	30.1	9.54	46.3	21.8	24.5	149{15200}	39.2{4000}	5.07
RF120-US-1	38.10	22.23	25.40	5.6	36.2	11.11	57.5	26.95	30.55	213{21700}	53.9{5500}	7.22
RF140-US-1	44.45	25.40	25.40	6.4	42.2	12.71	62.0	28.9	33.1	273{27800}	68.4{6970}	9.24
RF160-US-1	50.80	28.58	31.75	7.1	48.2	14.29	72.4	33.95	38.45	341{34800}	90.0{9180}	12.19
RF200-US-1	63.50	39.68	38.10	9.5	60.3	19.85	91.0	42.9	48.1	580{59100}	122{12410}	20.47
RF240-US-1	76.20	47.63	47.63	12.7	72.4	23.81	117.1	54.8	62.3	853{87000}	168{17170}	31.69

## Notes for use

- Select chains and sprockets using the Allowable Load Selection Method.
- Offset links are not available due to the super heavy-duty nature of transmission. Use an even number of links.
- Use drip lubrication, oil bath or splash lubrication, or forced pump lubrication.
- RS sprockets can be used, but cast iron sprockets cannot. Use sprockets made of S35C or higher carbon steel and harden the teeth of sprockets with low numbers of teeth.
- Check key strength, etc. Consider Tough Tooth sprockets (pgs. 17–18) with stronger hubs.
- Multi strand chains are not available. Consider a different Tsubaki Heavy Duty Chain if required.
- The specifications changed in October 2016 from "US" to "US-N." US-N has a smaller pin diameter than previous US. When replacing, replace the entire chain. This change does not affect the chain's minimum tensile strength or maximum allowable load.

# RS<sup>®</sup> Tough Tooth Sprocket

Tough Tooth sprockets have increased strength and durability to bring out the best in Tsubaki's new G8 Series Heavy Duty Drive Chains.



## Features

- Teeth have ample strength to handle the increased strength of the G8 Series Heavy Duty Chain. The hub has been further strengthened as well.
- All models feature hardened teeth to give the sprocket more wear resistance.
- A special coating that even further increases tooth hardness is also available (optional)—ideal for harsh operating environments where users want to reduce chain and sprocket replacement frequency. The coating has a Vickers hardness over 800 to give the sprocket more wear resistance.

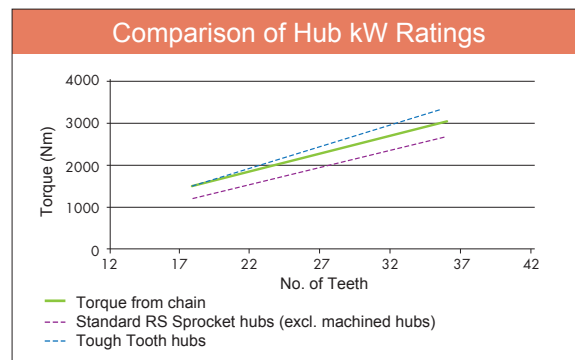
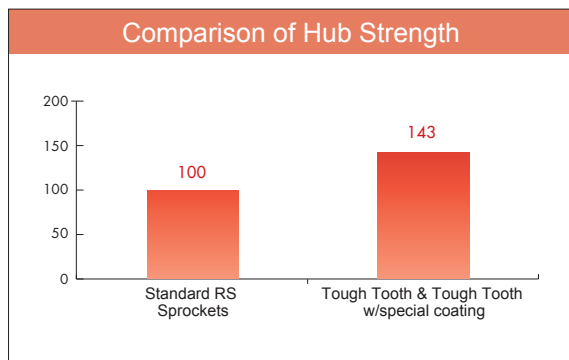

Note: 1. Torque is calculated from the keyway allowable surface pressure using a JIS parallel key at the maximum shaft hub diameter.  
2. Comparison using RS80-SUP-H-1.

## Specifications

- B and C types standardized for single and double strand RS-HT Series RS60 and above.
- RS-HT Chains and Super-H Chains in multi strand configurations have a different tooth transverse pitch than RS Roller Chain sprockets.
- Other multi strand configurations, hub types, and numbers of teeth are made-to-order. Other shaft hub finishing also available.
- Both teeth and hubs use carbon steel for machine structural use.
- Made-to-order product.

## Model Numbering Example

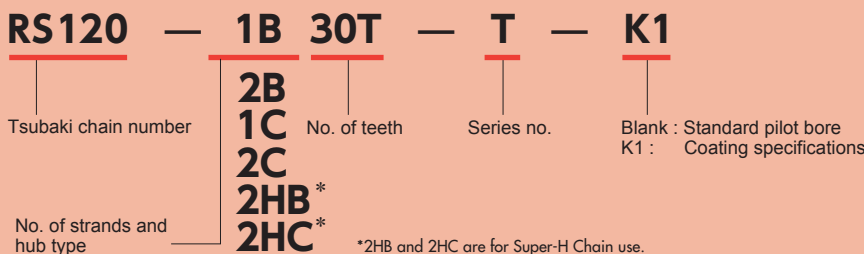

# The tooth hardening used on Tsubaki Sprockets is overwhelmingly superior.

## Comparison of Tooth Hardening

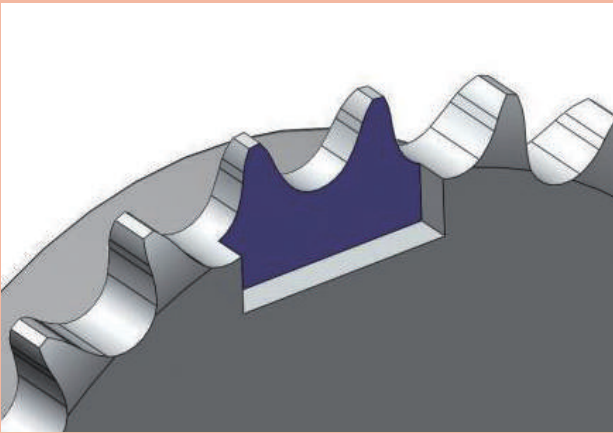

Cross-sectional observation of tooth hardening (darker area is the hardened layer)

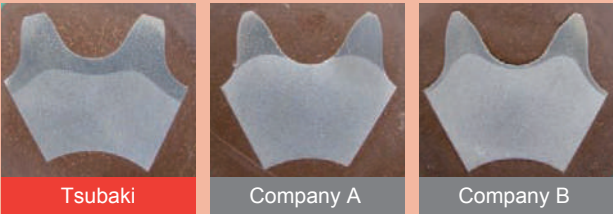

## Comparison of Tooth Hardness and Hardened Layer Depth

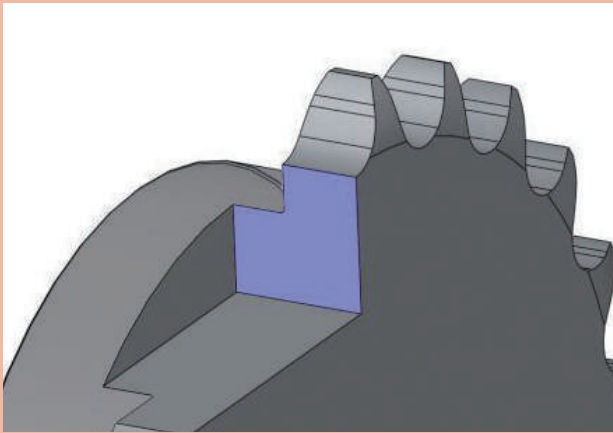

Cross-section observation of tooth hardened layer depth (darker area is the hardened layer)



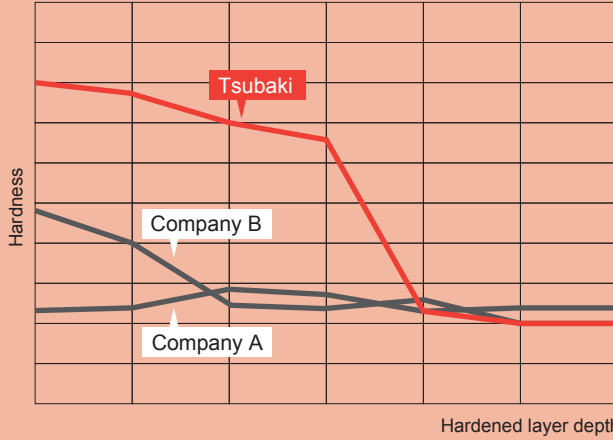
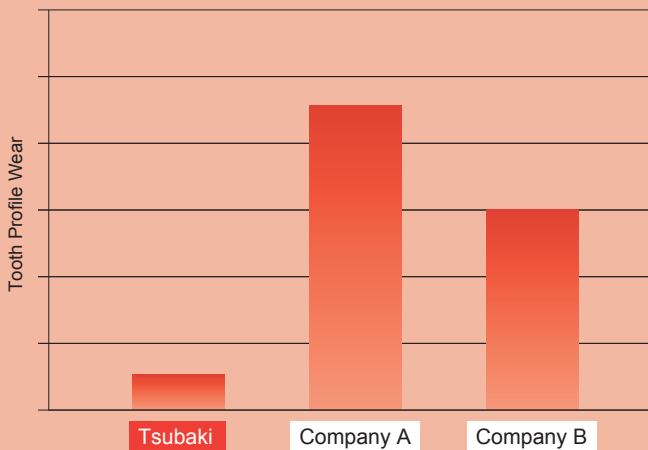

## Comparison of Tooth Profile Wear When Tested under Load

After 500 hours of testing RS40 sprockets for wear, the Tsubaki sprocket had the overwhelmingly superior wear performance.



# RS® Tough Tooth Sprockets

## Available Range

 RS Tough Tooth Sprockets  
 Use standard RS Sprockets

 Made-to-order

### ● 1B (single strand B type)

No. of Teeth/Size	RS60	RS80	RS100	RS120	RS140	RS160	RS180	RS200	RS240
9T									
10T									
11T									
12T									
13T									
14T									
15T									
16T									
17T									
18T									
19T									
20T									
21T									
22T									
23T									
24T									
25T									
26T									
27T									
28T									
30T									
32T									
34T									
35T									
36T									
38T									
40T or more									

### ● 1C (single strand C type)

No. of Teeth/Size	RS60	RS80	RS100	RS120	RS140	RS160	RS180	RS200	RS240
9T									
10T									
11T									
12T									
13T									
14T									
15T									
16T									
17T									
18T									
19T									
20T									
21T									
22T									
23T									
24T									
25T									
26T									
27T									
28T									
30T									
32T									
34T									
35T									
36T									
38T									
40T or more									

Refer to the Tsubaki Drive Chains & Sprockets catalog for information on material and dimensions.

- Contact a Tsubaki representative for any inquiries.
- Sizes, nos. of teeth, and hub dimensions not shown above, as well as multi strand configurations, are made-to-order items.

● 2B (double strand B type)

No. of Teeth/Size	RS60	RS80	RS100	RS120	RS140~240
9T					
10T					
11T					
12T					
13T					
14T					
15T					
16T					
17T					
18T					
19T					
20T					
21T					
22T					
23T					
24T					
25T					
26T					
27T					
28T					
30T					
32T					
34T					
35T					
36T or more					

● 2C (double strand C type)

No. of Teeth/Size	RS60	RS80	RS100	RS120	RS140~240
9T					
10T					
11T					
12T					
13T					
14T					
15T					
16T					
17T					
18T					
19T					
20T					
21T					
22T					
23T					
24T					
25T					
26T					
27T					
28T					
30T					
32T					
34T					
35T					
36T or more					

Refer to the Tsubaki Drive Chains & Sprockets catalog for information on material and dimensions.

- The tooth transverse pitch differs with Super-H triple strand and above.
- Contact a Tsubaki representative for any inquiries.
- Sizes, nos. of teeth, and hub dimensions not shown above, as well as multi strand configurations, are made-to-order items.

Optional (made-to-order)

Special Coating Specifications

A special coating gives the teeth a hardness of over HV800 for better wear resistance. Effective in harsh operating environments where sprocket replacement frequency is high.

Shaft Bore Finishing Service

Optional shaft bore finishing service available.

Shaft Set Delivery

We can quote you for a shaft based on your drawings, manufacture it, and supply it together with your sprocket as a set. By also requesting inspection records, you can reduce inspection/assembly man-hours and cost.

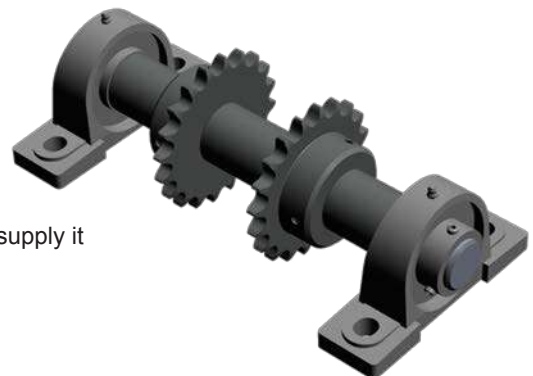

# Selection

When Heavy Duty Drive Chain is used in winding drives, then they can be selected using the General Selection Method or the Allowable Load Selection Method. Refer to the Tsubaki Drive Chains & Sprockets catalog for more information. See below for the easy selection graphs for RS-HT and Super Chains.

## RS-SUP Easy Selection Graph

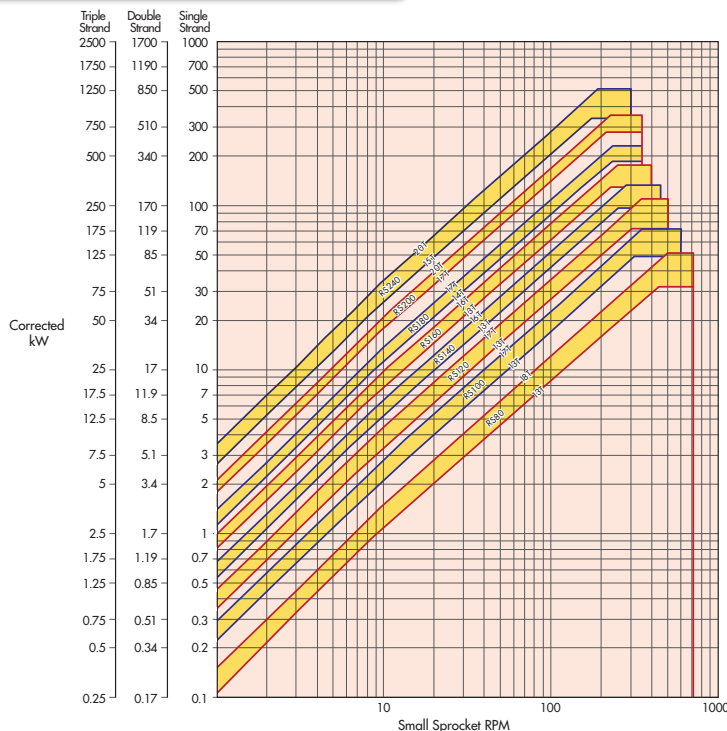

### Understanding the Graph

1. (Ex.) For single strand chains with a corrected kW of 20kW

(1) For small sprockets at 100rpm

Looking at the corrected kW of 7kW (X-axis) and RPM (Y-axis), an RS100 chain has a sprocket smaller than 17T and larger than 13T, so from the intersection of those a 15T sprocket can be used.

(2) For small sprockets at 200rpm

Using the preceding example, the sprocket is smaller than RS80-18T and larger than RS80-13T. Because we performed a rough selection using this graph, as we did above, you will want to confirm the selection using the kilowatt ratings table for each chain number.

(3) Allow for a decrease in kilowatt ratings when using offset links as noted under each kilowatt ratings table.

## RS-HT Easy Selection Graph

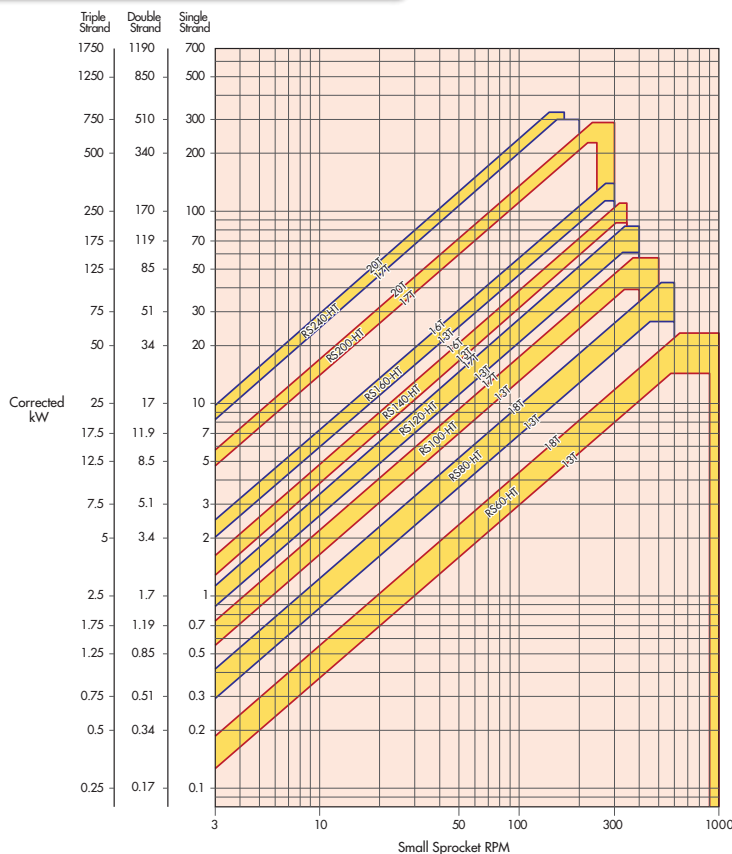

### Ordering

Refer to the Tsubaki Drive Chains & Sprockets catalog for more information on ordering Heavy Duty Drive Chains and Sprockets.

# For Your Safety When Using the Chain



## **Warning** To avoid danger, observe the following rules.

- Do not use chain or chain accessories for any purpose other than their originally intended use.
- Never perform additional work on chain.
  - Do not anneal any chain parts.
  - Do not clean chain with acids or alkalis. These may cause cracking.
  - Never attempt to electroplate chain or chain parts. This may cause hydrogen embrittlement.
  - Do not weld chain. Heating effects will cause weakening and cracking.
  - When a torch is used to heat or cut chain, remove the links on each side and do not reuse them.
- When replacing a worn or damaged part, do not replace just the worn or damaged part. Replace all parts with new parts.
- If a material that causes hydrogen embrittlement (acid, strong alkali, battery fluid, etc.) comes in contact with the chain, immediately stop using the chain and replace it with new chain.
- When using chain in a lifting device, set up a safety barrier and do not allow anyone to go under the equipment.
- Always install safety equipment (safety covers, etc.) on chain and sprockets.
- Strictly observe the general guidelines listed in Section 1, Chapter 1, 2nd Edition of the Japanese Occupational Safety and Health Regulations as well as rules and regulations concerning occupational safety and health in your region/country.
- When installing, removing, inspecting, maintaining and oiling chain,
  - Perform the work as instructed in the manual, catalog or other documentation that was provided with the product.
  - Before starting work, turn off the power switch and take measures to prevent it from being turned on accidentally.
  - Secure the chain and parts to prevent them from moving freely.
  - Use a press tool or other special tools to separate or connect chain, and follow the correct procedures.
  - Remove and insert pins and rivets in the correct direction.
  - Wear clothing and protective gear (safety glasses, gloves, safety shoes, etc.) that are appropriate for the work.
  - Only experienced personnel should perform chain replacement.



## **Caution** To prevent accidents, observe the following rules.

- Understand the structure and specifications of the chain that you are handling.
- Before installing chain, inspect it to make sure no damage occurred during delivery.
- Inspect and maintain chain and sprockets at regular intervals.
- Chain strength varies by manufacturer. Only Tsubaki products should be used when chain is selected using Tsubaki catalogs.
- Minimum tensile strength refers to the failure point when the corresponding load is applied to the chain once and does not refer to the allowable operational load.

## Warranty

### 1. LIMITED WARRANTY

Products manufactured by Seller: (a) conform to the design and specifications, if any, expressly agreed to in writing by Seller; and (b) are free of defects in workmanship and materials at the time of shipment. The warranties set forth in the preceding sentence are exclusive of all other warranties, express or implied, and extend only to Buyer and to no other person. ALL WARRANTIES OF MERCHANTABILITY OR FITNESS FOR A PARTICULAR PURPOSE ARE HEREBY EXCLUDED.

### 2. NON-RELIANCE

Buyer is not relying upon any advice, representations or warranties (except the warranties expressly set forth above) of Seller, or upon Seller's skill or judgment regarding the Seller's products.

Buyer is solely responsible for the design and specifications of the products, including without limitation, the determination of suitability for Buyer's application of the products.

### 3. CLAIMS

- (a) Any claim relating to quantity or type shall be made to Seller in writing within 7 days after receipt of the products; any such claim made thereafter shall be barred.
- (b) Any claim under the above-stated Limited Warranty shall be made to Seller in writing within three (3) months after receipt of the products; any such claim made thereafter shall be barred.
- (c) Seller's liability for breach of warranty or otherwise is limited to repair or replacement, at Seller's option, of non-conforming or defective products. Buyer waives all other remedies, including, but not limited to, all rights to

consequential, special or incidental damages, including, but not limited to, damages resulting from personal injury, death or damage to or loss of use of property.  
(d) Repair, alteration, neglect or misuse of the products shall void all applicable warranties.

### 4. INDEMNIFICATION

Buyer will indemnify, defend and hold Seller harmless from all loss, liability, damage and expense, including attorneys' fees, arising out of any claim (a) for infringement of any patent, trademark, copyright, misappropriation of trade secrets, unfair competition or similar charge by any products supplied by Seller in accordance with the design or specifications furnished by Buyer, or (b) arising out of or connected with the products or any items into which the products are incorporated, including, but not limited to, any claim for product liability (whether or not based on negligence or strict liability of Seller), breach of warranty, breach of contract or otherwise.

### 5. ENTIRE AGREEMENT

These terms and conditions constitute the entire agreement between Buyer and Seller and supersede any inconsistent terms and conditions, whether contained in Buyer's purchase order or otherwise, and whether made heretofore or hereafter.

No statement or writing subsequent to the date hereof which purports to modify or add to the terms and conditions hereof shall be binding unless consented to in writing, which makes specific reference hereto, and which has been signed by the party against which enforcement thereof is sought. Seller reserves the right to change these terms and conditions without prior notice.

Note: The logos, brand names, or product names in this catalog are trademarks or registered trademarks of Tsubakimoto Chain Co. in Japan and other countries.



## TSUBAKIMOTO CHAIN CO.

Japan	Headquarters	+81 6-6441-0011	<a href="http://tsubakimoto.com">http://tsubakimoto.com</a>
-------	--------------	-----------------	---

### Global Group Companies

#### AMERICAS

United States of America	U.S. TSUBAKI POWER TRANSMISSION, LLC	+1 847-459-9500	<a href="http://www.ustsubaki.com/">http://www.ustsubaki.com/</a>
Brazil	TSUBAKI BRASIL EQUIPAMENTOS INDUSTRIAIS LTDA.	+55 11-3253-5656	<a href="http://tsubaki.ind.br/">http://tsubaki.ind.br/</a>
Canada	TSUBAKI of CANADA LIMITED	+1 905-676-0400	<a href="http://tsubaki.ca/">http://tsubaki.ca/</a>

#### EUROPE

Netherlands	TSUBAKI EUROPE B.V.	+31 78-6204000	<a href="http://tsubaki.eu/">http://tsubaki.eu/</a>
France	KABELSCHLEPP FRANCE S.A.R.L.	+33 1-34846365	<a href="http://kabelschlepp.fr/">http://kabelschlepp.fr/</a>
Germany	TSUBAKI DEUTSCHLAND GmbH	+49 8105-7307100	<a href="http://tsubaki.de/">http://tsubaki.de/</a>
	TSUBAKI KABELSCHLEPP GmbH	+49 2762-4003-0	<a href="http://kabelschlepp.de/">http://kabelschlepp.de/</a>
Italy	KABELSCHLEPP ITALIA S.R.L.	+39 0331-350962	<a href="http://kabelschlepp.it/">http://kabelschlepp.it/</a>
Russia	OOO TSUBAKI KABELSCHLEPP	+7 499-4180212	<a href="http://kabelschlepp.ru/">http://kabelschlepp.ru/</a>
United Kingdom	TSUBAKIMOTO U.K. LTD.	+44 1623-688-700	<a href="http://tsubaki.eu/">http://tsubaki.eu/</a>

#### INDIAN OCEAN RIM

Singapore	TSUBAKIMOTO SINGAPORE PTE. LTD.	+65 6861-0422/3/4	<a href="http://tsubaki.sg/">http://tsubaki.sg/</a>
Australia	TSUBAKI AUSTRALIA PTY. LTD.	+61 2-9704-2500	<a href="http://tsubaki.com.au/">http://tsubaki.com.au/</a>
India	TSUBAKI INDIA POWER TRANSMISSION PTE. LTD.	+91 44-4231-5251	<a href="http://tsubaki.sg/">http://tsubaki.sg/</a>
Indonesia	PT. TSUBAKI INDONESIA TRADING	+62 21-571-4230/1	<a href="http://tsubakimoto.co.id/">http://tsubakimoto.co.id/</a>
Malaysia	TSUBAKI POWER TRANSMISSION (MALAYSIA) SDN. BHD.	+60 3-7859-8585	<a href="http://tsubaki.sg/">http://tsubaki.sg/</a>
New Zealand	TSUBAKI AUSTRALIA PTY LIMITED - NEW ZEALAND BRANCH	+64 275-082-726	<a href="http://tsubaki.com.au/">http://tsubaki.com.au/</a>
Philippines	TSUBAKIMOTO SINGAPORE PTE. LTD. - PHILIPPINES REPRESENTATIVE OFFICE	+63 2-464-7129	<a href="http://tsubaki.ph/">http://tsubaki.ph/</a>
Thailand	TSUBAKIMOTO (THAILAND) CO., LTD.	+66 2-262-0667	<a href="http://tsubaki.co.th/">http://tsubaki.co.th/</a>
Vietnam	TSUBAKIMOTO SINGAPORE PTE. LTD. - VIETNAM REPRESENTATIVE OFFICE	+84 8-3999-0131/2	<a href="http://tsubaki.net.vn/">http://tsubaki.net.vn/</a>

#### EAST ASIA

Korea	TSUBAKIMOTO KOREA CO., LTD.	+82 2-2183-0311	<a href="http://tsubakimoto-tck.co.kr/">http://tsubakimoto-tck.co.kr/</a>
Taiwan	TAIWAN TSUBAKIMOTO CO.	+886 33-293827/8/9	<a href="http://tsubakimoto.com.tw/">http://tsubakimoto.com.tw/</a>

#### CHINA

China	TSUBAKIMOTO CHAIN (SHANGHAI) CO., LTD.	+86 215396-6651/2	<a href="http://tsubaki.cn/">http://tsubaki.cn/</a>
-------	--	-------------------	---



The Tsubaki Eco Link logo is used only on products that satisfy the standards for environmental friendliness set by the Tsubaki Group.