

Brake-Type Gear Motor TA Series Outline Dimensions

Three-phase 0.1 kW · L : Foot mount brake type

GEAR MOTOR TA Series

B-11 0.1kW GMTA010-18L5B

Reduction ratio : 5 Approx. weight : 8.4kg
Reference page : Specification Chart→P25

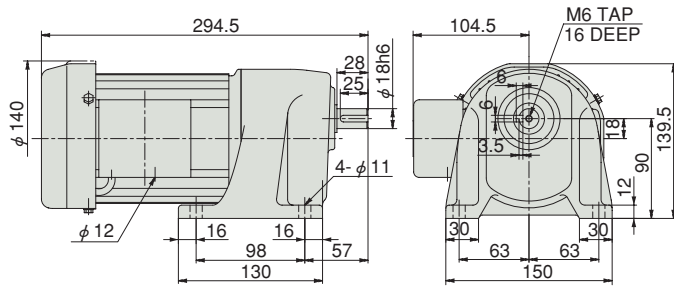

B-14 0.1kW GMTA010-28L300~450B

Reduction ratio : 300, 360, 450 Approx. weight : 12.0kg
Reference page : Specification Chart→P25

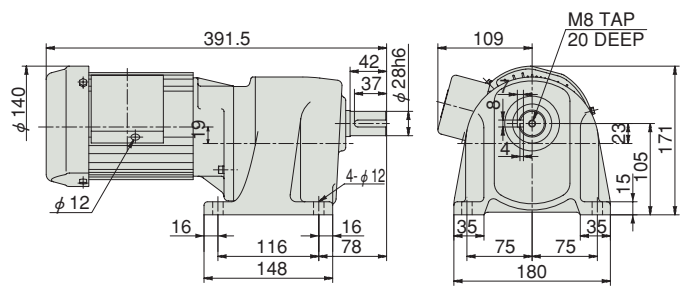

B-12 0.1kW GMTA010-18L10~50B

Reduction ratio : 10, 15, 20, 25, 30, 40, 50 Approx. weight : 7.0kg
Reference page : Specification Chart→P25

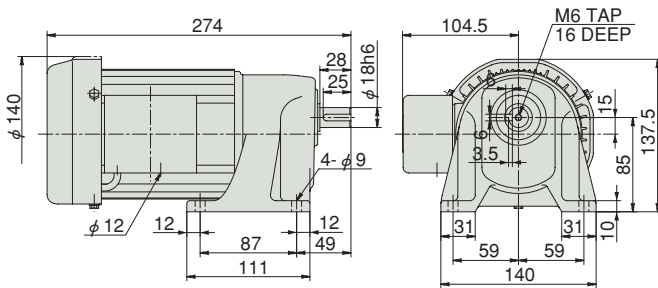

B-15 0.1kW GMTA010-38L600~1200B

Reduction ratio : 600, 720, 1000, 1200 Approx. weight : 16.0kg
Reference page : Specification Chart→P25

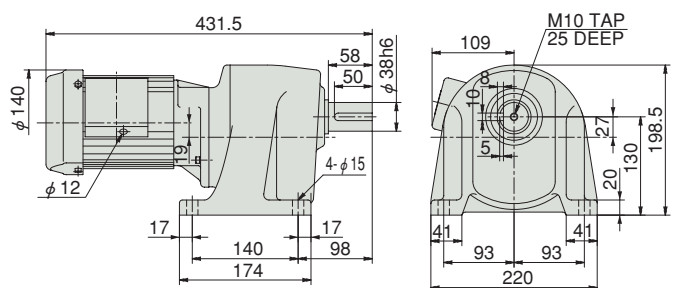

B-13 0.1kW GMTA010-24L60~200B

Reduction ratio : 60, 75, 100, 120, 165, 200 Approx. weight : 8.4kg
Reference page : Specification Chart→P25

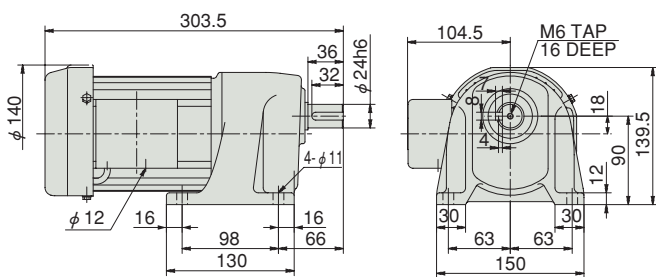

Outline Dimensions

L
B-11
B-12
B-13
B-14
B-15

0.1

Brake-Type Gear Motor TA Series Outline Dimensions

Three-phase 0.1 kW · U : Face mount brake type

GEAR MOTOR TA Series

B-16 0.1kW GMTA010-18U5B

Reduction ratio : 5 Approx. weight : 8.2kg
Reference page : Specification Chart→P25 Options→P57

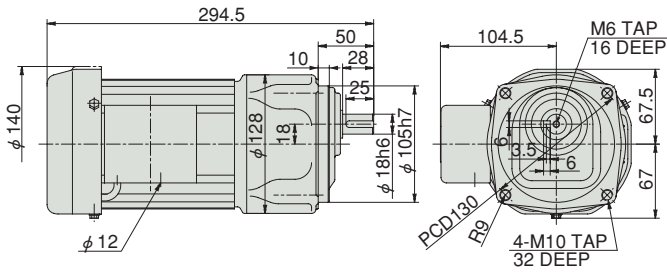

B-19 0.1kW GMTA010-28U300~450B

Reduction ratio : 300, 360, 450 Approx. weight : 12.0kg
Reference page : Specification Chart→P25 Options→P57

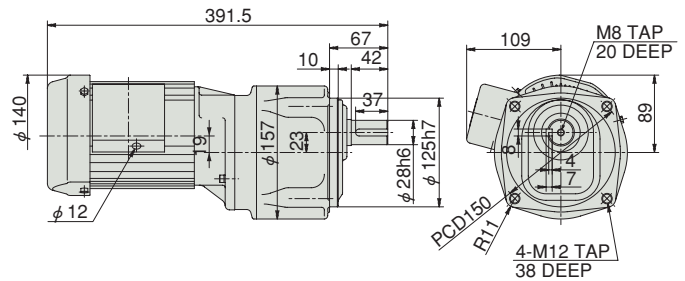

B-17 0.1kW GMTA010-18U10~50B

Reduction ratio : 10, 15, 20, 25, 30, 40, 50 Approx. weight : 6.8kg
Reference page : Specification Chart→P25 Options→P57

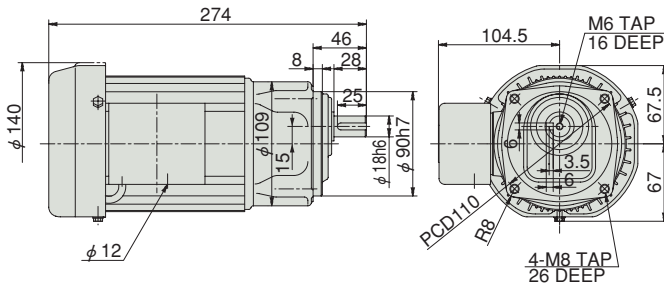

B-20 0.1kW GMTA010-38U600~1200B

Reduction ratio : 600, 720, 1000, 1200 Approx. weight : 22.0kg
Reference page : Specification Chart→P25 Options→P58

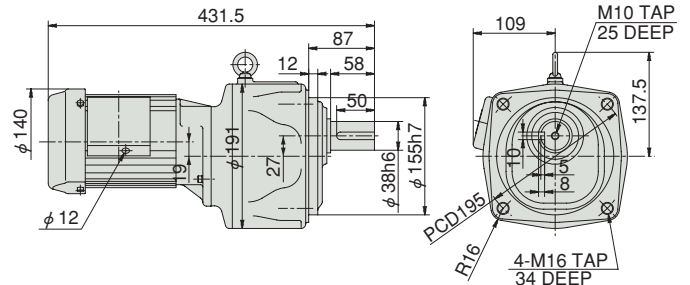

B-18 0.1kW GMTA010-24U60~200B

Reduction ratio : 60, 75, 100, 120, 165, 200 Approx. weight : 8.4kg
Reference page : Specification Chart→P25 Options→P57

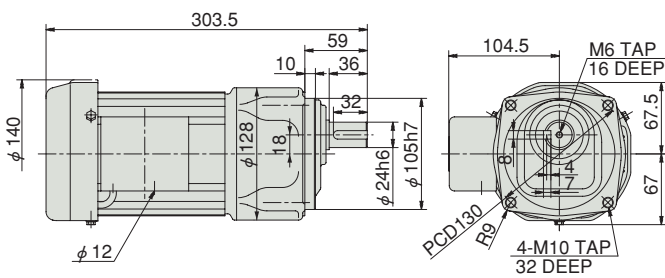

Outline Dimensions

U

B-16
B-17
B-18
B-19
B-20

0.1

Brake-Type Gear Motor TA Series Outline Dimensions

Three-phase 0.2 kW · L : Foot mount brake type

GEAR MOTOR TA Series

B-21 0.2kW GMTA020-18L5B

Reduction ratio : 5 Approx. weight : 8.8kg
Reference page : Specification Chart→P25

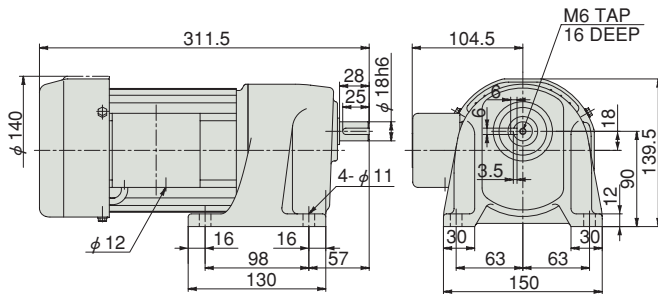

B-24 0.2kW GMTA020-28L100~200B

Reduction ratio : 100, 120, 165, 200 Approx. weight : 11.3kg
Reference page : Specification Chart→P25

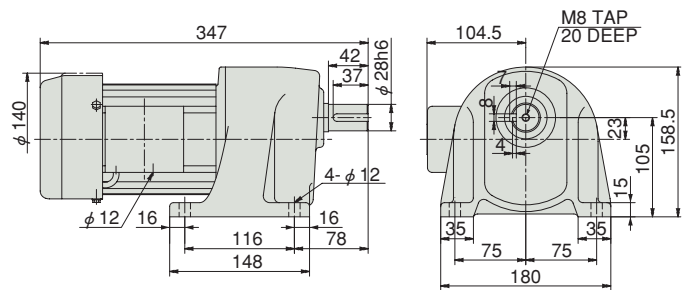

B-22 0.2kW GMTA020-18L10~25B

Reduction ratio : 10, 15, 20, 25 Approx. weight : 7.6kg
Reference page : Specification Chart→P25

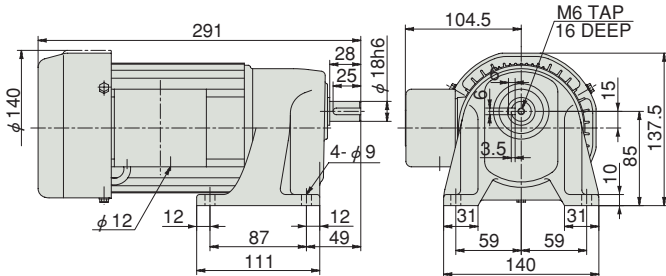

B-25 0.2kW GMTA020-38L300~450B

Reduction ratio : 300, 360, 450 Approx. weight : 17.3kg
Reference page : Specification Chart→P25

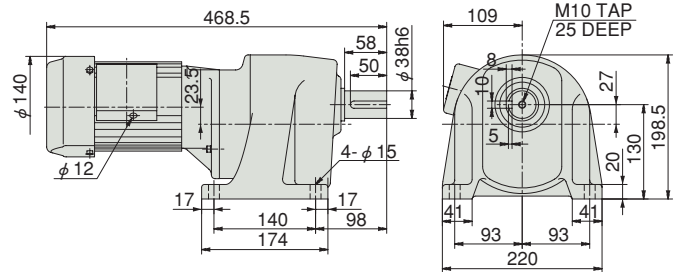

B-23 0.2kW GMTA020-24L30~75B

Reduction ratio : 30, 40, 50, 60, 75 Approx. weight : 9.0kg
Reference page : Specification Chart→P25

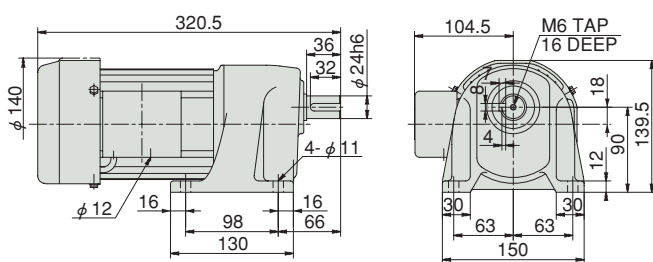

B-26 0.2kW GMTA020-42L600~1200B

Reduction ratio : 600, 720, 1000, 1200 Approx. weight : 39.0kg
Reference page : Specification Chart→P25

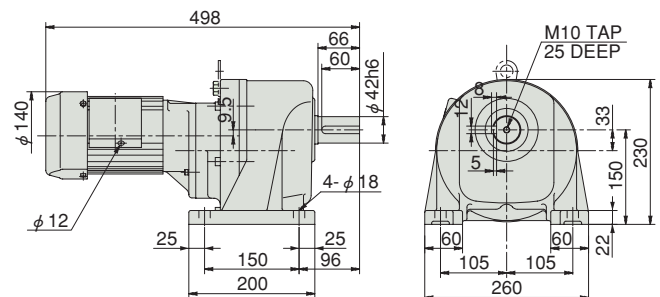

Outline Dimensions

L
B-21
B-22
B-23
B-24
B-25
B-26

0.2

Brake-Type Gear Motor TA Series Outline Dimensions

Three-phase 0.2 kW · U : Face mount type / F : Flange mount brake type

GEAR MOTOR TA Series

B-27 0.2kW GMTA020-18U5B

Reduction ratio : 5	Approx. weight : 8.8kg
Reference page : Specification Chart→P25 Options→P57	

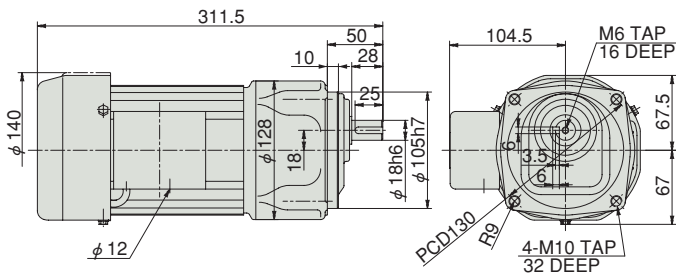

B-30 0.2kW GMTA020-28U100~200B

Reduction ratio : 100, 120, 165, 200	Approx. weight : 11.3kg
Reference page : Specification Chart→P25 Options→P57	

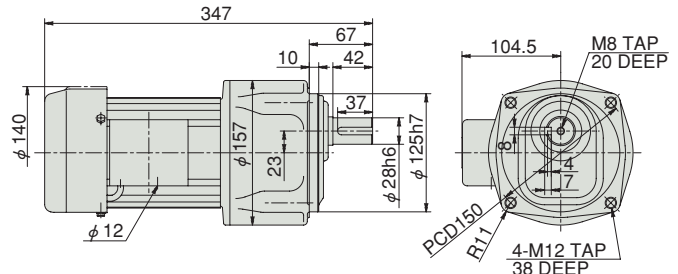

B-28 0.2kW GMTA020-18U10~25B

Reduction ratio : 10, 15, 20, 25	Approx. weight : 7.4kg
Reference page : Specification Chart→P25 Options→P57	

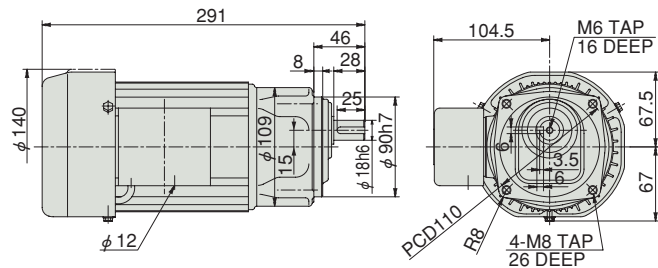

B-31 0.2kW GMTA020-38U300~450B

Reduction ratio : 300, 360, 450	Approx. weight : 23.3kg
Reference page : Specification Chart→P25 Options→P58	

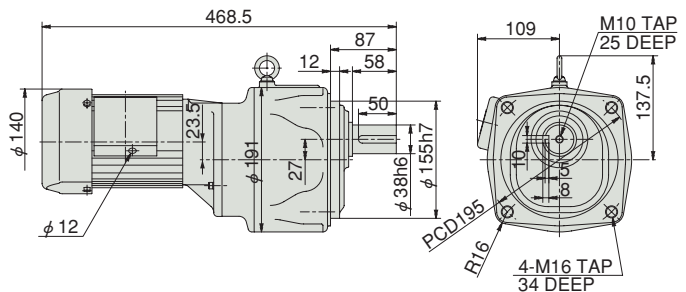

B-29 0.2kW GMTA020-24U30~75B

Reduction ratio : 30, 40, 50, 60, 75	Approx. weight : 8.8kg
Reference page : Specification Chart→P25 Options→P57	

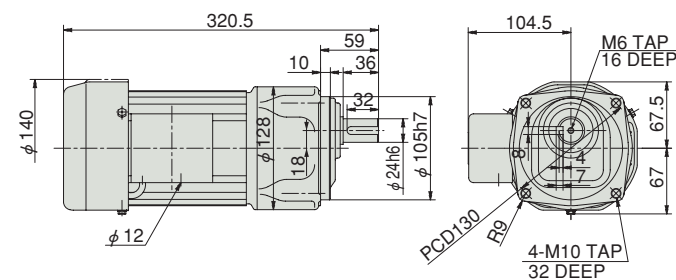

B-32 0.2kW GMTA020-42F600~1200B

Reduction ratio : 600, 720, 1000, 1200	Approx. weight : 41.0kg
Reference page : Specification Chart→P25	

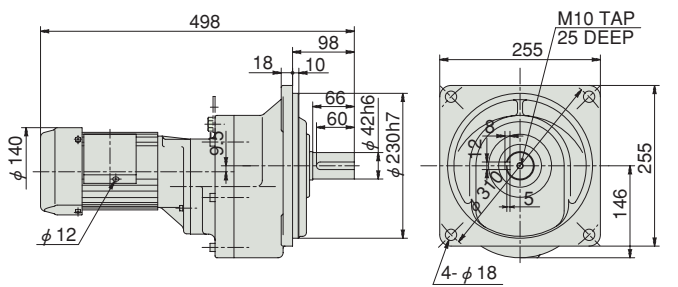

Outline Dimensions

U.F
B-27
B-28
B-29
B-30
B-31
B-32

0.2

Brake-Type Gear Motor TA Series Outline Dimensions

Three-phase 0.4 kW · L : Foot mount brake type

GEAR MOTOR TA Series

B-33 0.4kW GMTA040-24L5~25B

Reduction ratio : 5, 10, 15, 20, 25 Approx. weight : 10.0kg
Reference page : Specification Chart→P26

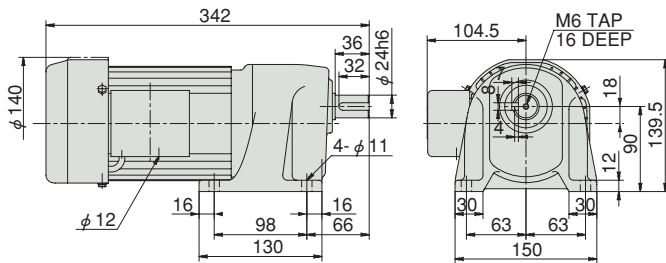

B-36 0.4kW GMTA040-42L300~450B

Reduction ratio : 300, 360, 450 Approx. weight : 44.9kg
Reference page : Specification Chart→P26

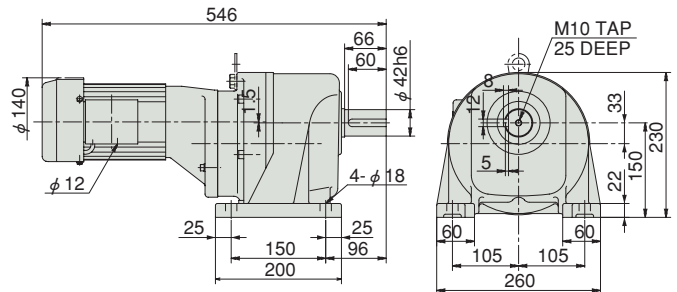

B-34 0.4kW GMTA040-28L30~75B

Reduction ratio : 30, 40, 50, 60, 75 Approx. weight : 12.5kg
Reference page : Specification Chart→P26

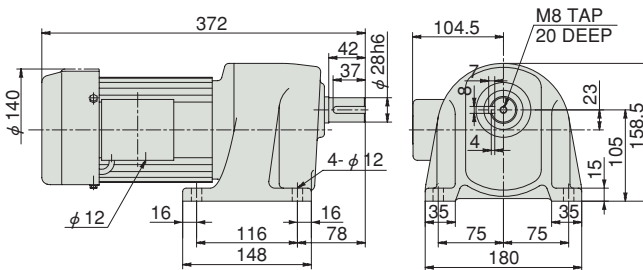

B-37 0.4kW GMTA040-50L600~1200B

Reduction ratio : 600, 720, 1000, 1200 Approx. weight : 64.9kg
Reference page : Specification Chart→P26

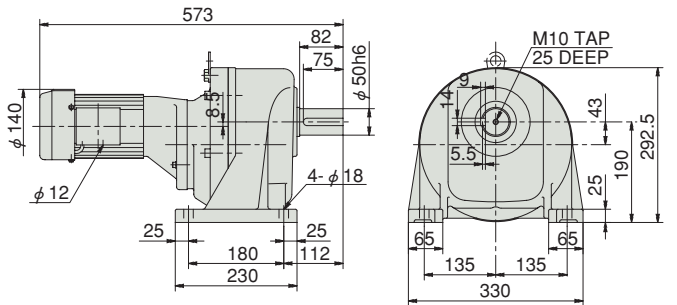

B-35 0.4kW GMTA040-38L100~200B

Reduction ratio : 100, 120, 165, 200 Approx. weight : 16.5kg
Reference page : Specification Chart→P26

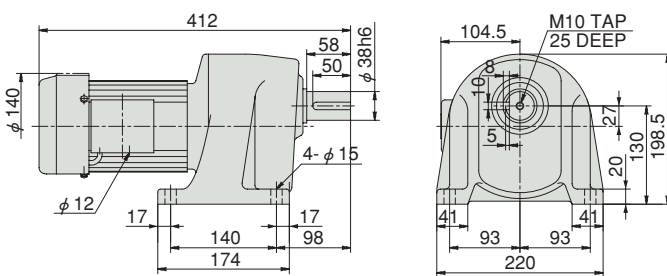

Brake-Type Gear Motor TA Series Outline Dimensions

Three-phase 0.4 kW · U : Face mount type / F : Flange mount brake type

GEAR MOTOR TA Series

B-38 0.4kW GMTA040-24U5~25B

Reduction ratio : 5, 10, 15, 20, 25 Approx. weight : 10.0kg
Reference page : Specification Chart→P26 Options→P57

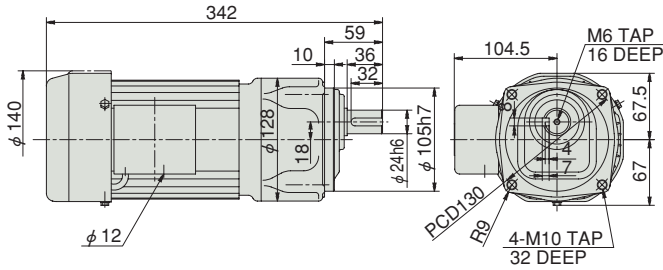

B-41 0.4kW GMTA040-42F300~450B

Reduction ratio : 300, 360, 450 Approx. weight : 45.9kg
Reference page : Specification Chart→P26

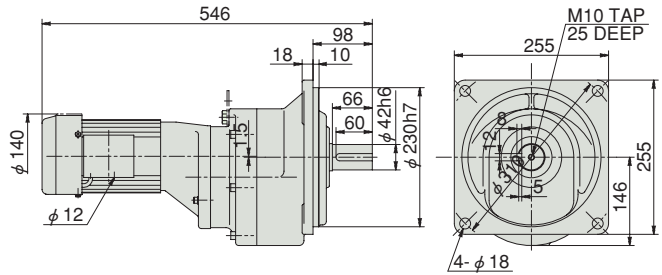

B-39 0.4kW GMTA040-28U30~75B

Reduction ratio : 30, 40, 50, 60, 75 Approx. weight : 12.5kg
Reference page : Specification Chart→P26 Options→P57

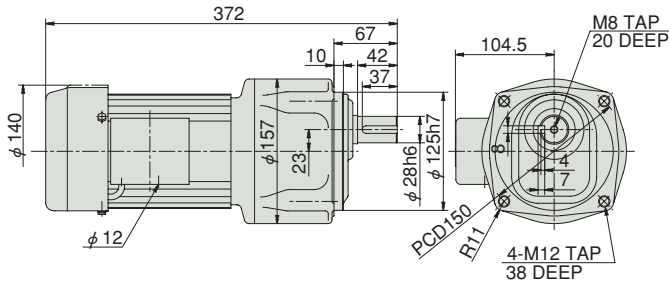

B-42 0.4kW GMTA040-50F600~1200B

Reduction ratio : 600, 720, 1000, 1200 Approx. weight : 66.9kg
Reference page : Specification Chart→P26

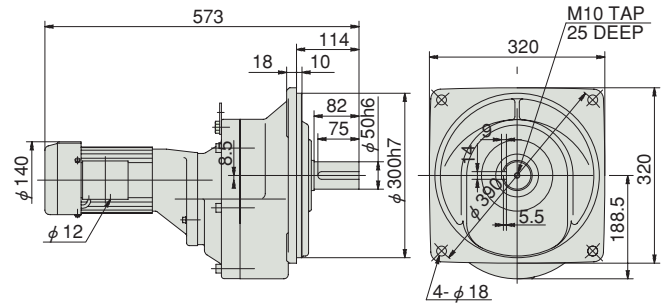

B-40 0.4kW GMTA040-38U100~200B

Reduction ratio : 100, 120, 165, 200 Approx. weight : 22.0kg
Reference page : Specification Chart→P26 Options→P58

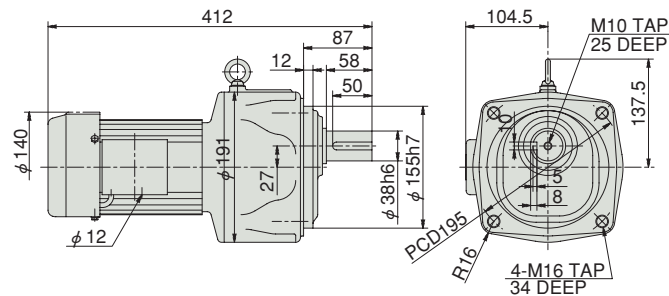

Brake-Type Gear Motor TA Series Outline Dimensions

Three-phase 0.75 kW · L : Foot mount type / U : Face mount type / F : Flange mount brake type

GEAR MOTOR TA Series

B-43 0.75kW GMTA075-28L5~25B

Reduction ratio : 5, 10, 15, 20, 25 Approx. weight : 16.0kg
Reference page : Specification Chart→P26

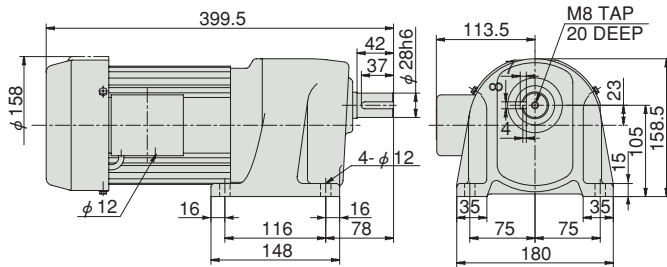

B-47 0.75kW GMTA075-28U5~25B

Reduction ratio : 5, 10, 15, 20, 25 Approx. weight : 16.0kg
Reference page : Specification Chart→P26 Options→P57

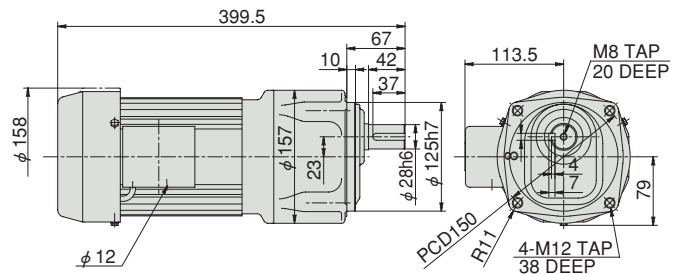

B-44 0.75kW GMTA075-38L30~75B

Reduction ratio : 30, 40, 50, 60, 75 Approx. weight : 20.0kg
Reference page : Specification Chart→P26

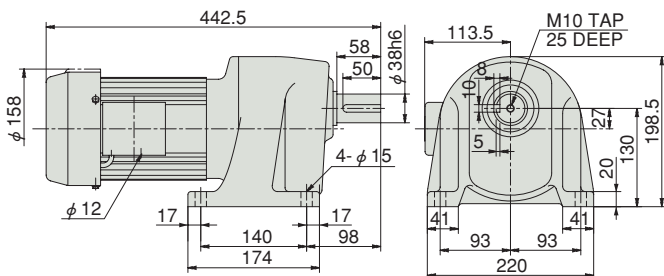

B-48 0.75kW GMTA075-38U30~75B

Reduction ratio : 30, 40, 50, 60, 75 Approx. weight : 25.5kg
Reference page : Specification Chart→P26 Options→P58

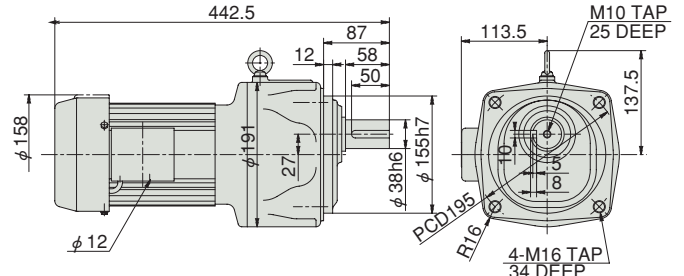

B-45 0.75kW GMTA075-42L100~200B

Reduction ratio : 100, 120, 165, 200 Approx. weight : 41.0kg
Reference page : Specification Chart→P26

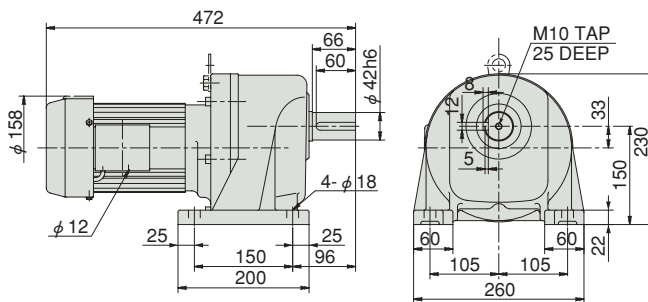

B-49 0.75kW GMTA075-42F100~200B

Reduction ratio : 100, 120, 165, 200 Approx. weight : 43.0kg
Reference page : Specification Chart→P26

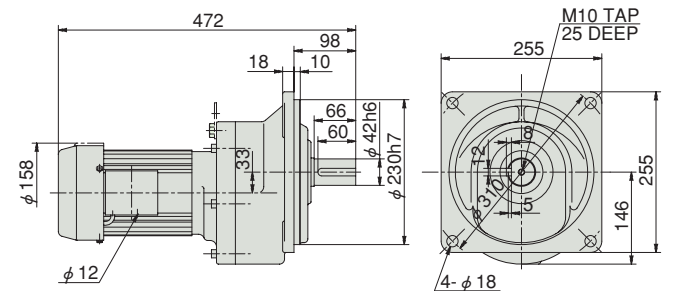

B-46 0.75kW GMTA075-50L300~450B

Reduction ratio : 300, 360, 450 Approx. weight : 65.0kg
Reference page : Specification Chart→P26

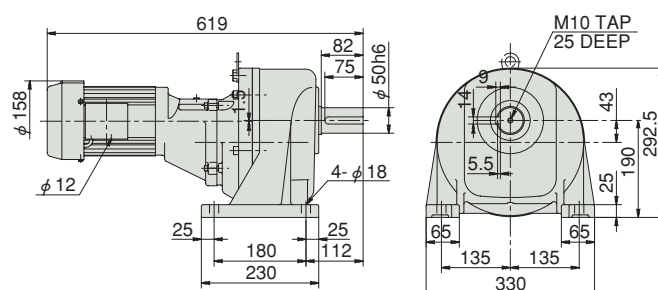

B-50 0.75kW GMTA075-50F300~450B

Reduction ratio : 300, 360, 450 Approx. weight : 68.0kg
Reference page : Specification Chart→P26

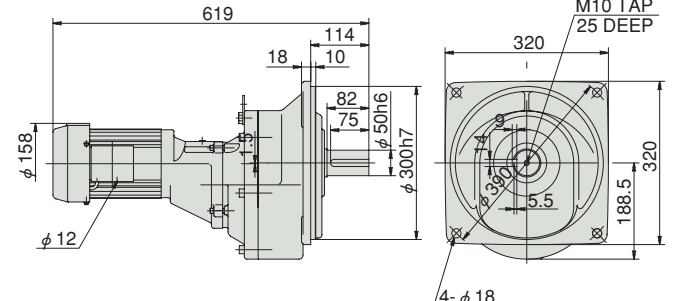

Brake-Type Gear Motor TA Series Outline Dimensions

Three-phase 1.5 kW · L : Foot mount type / U : Face mount type / F : Flange mount brake type

GEAR MOTOR TA Series

B-51 1.5kW GMTA150-38L5~30B

Reduction ratio : 5, 10, 15, 20, 25, 30	Approx. weight : 31.0kg
Reference page : Specification Chart→P26	

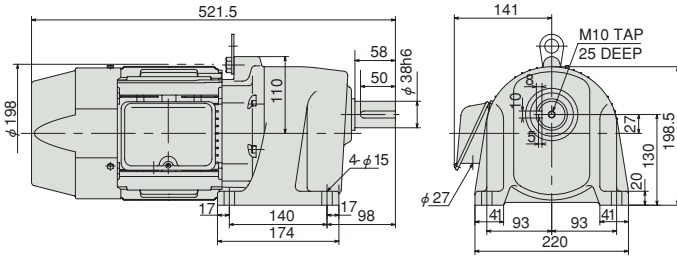

B-54 1.5kW GMTA150-38U5~30B

Reduction ratio : 5, 10, 15, 20, 25, 30	Approx. weight : 38.0kg
Reference page : Specification Chart→P26 Options→P58	

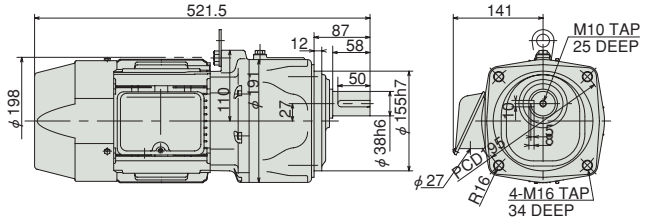

B-52 1.5kW GMTA150-42L40~75B

Reduction ratio : 40, 50, 60, 75	Approx. weight : 52.0kg
Reference page : Specification Chart→P26	

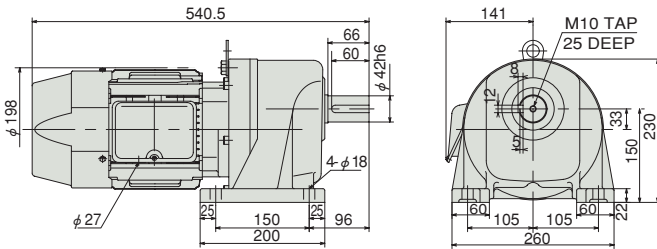

B-55 1.5kW GMTA150-42F40~75B

Reduction ratio : 40, 50, 60, 75	Approx. weight : 53.0kg
Reference page : Specification Chart→P26	

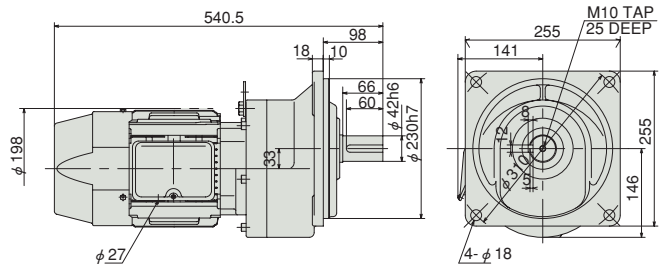

B-53 1.5kW GMTA150-50L100~200B

Reduction ratio : 100, 120, 165, 200	Approx. weight : 72.0kg
Reference page : Specification Chart→P26	

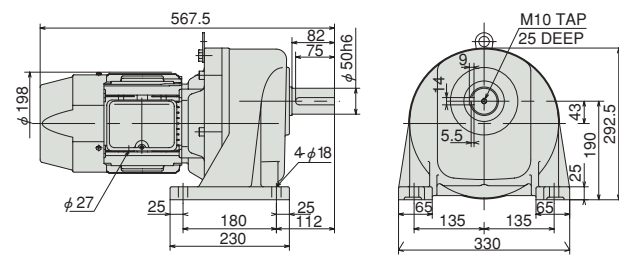

B-56 1.5kW GMTA150-50F100~200B

Reduction ratio : 100, 120, 165, 200	Approx. weight : 74.0kg
Reference page : Specification Chart→P26	

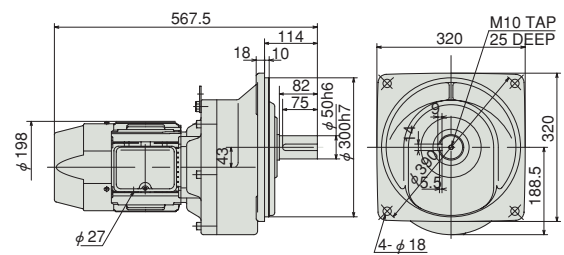

Brake-Type Gear Motor TA Series Outline Dimensions

Three-phase 2.2 kW · L : Foot mount type / U : Flange mount brake type

GEAR MOTOR TA Series

B-57 2.2kW GMTA220-42L5~30B

Reduction ratio : 5, 10, 15, 20, 25, 30 Approx. weight : 51.0kg
Reference page : Specification Chart→P27

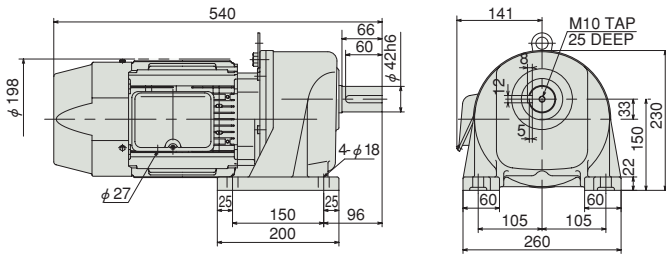

B-60 2.2kW GMTA220-42F5~30B

Reduction ratio : 5, 10, 15, 20, 25, 30 Approx. weight : 53.0kg
Reference page : Specification Chart→P27

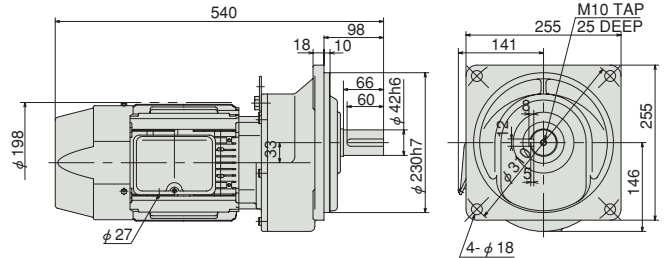

B-58 2.2kW GMTA220-50L40~75B

Reduction ratio : 40, 50, 60, 75 Approx. weight : 72.0kg
Reference page : Specification Chart→P27

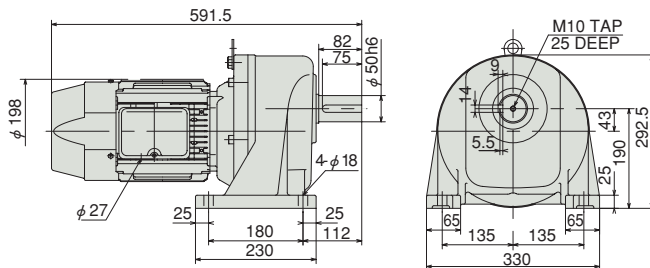

B-61 2.2kW GMTA220-50F40~75B

Reduction ratio : 40, 50, 60, 75 Approx. weight : 75.0kg
Reference page : Specification Chart→P27

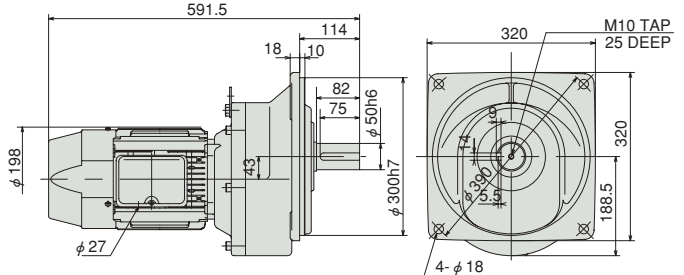

B-59 2.2kW GMTA220-63L100~200B

Reduction ratio : 100, 120, 165, 200 Approx. weight : 103.0kg
Reference page : Specification Chart→P27

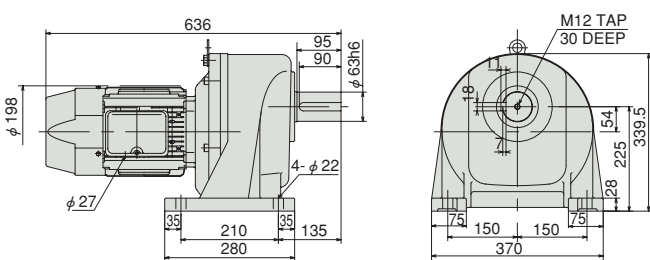

B-62 2.2kW GMTA220-63F100~200B

Reduction ratio : 100, 120, 165, 200 Approx. weight : 107.0kg
Reference page : Specification Chart→P27

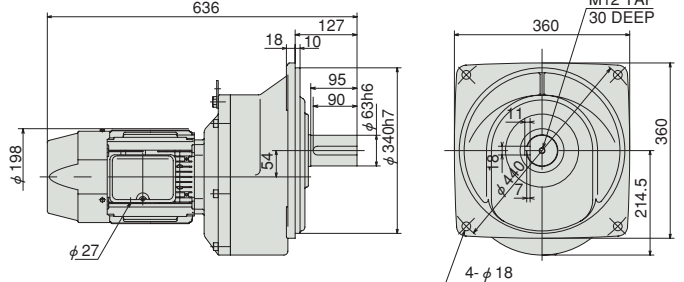

Brake-Type Gear Motor TA Series Outline Dimensions

Three-phase 3.7 kW · L : Foot mount type / U : Flange mount brake type

GEAR MOTOR TA Series

B-63 3.7kW GMTA370-50L5~30B

Reduction ratio : 5, 10, 15, 20, 25, 30	Approx. weight : 80.0kg
Reference page : Specification Chart→P27	

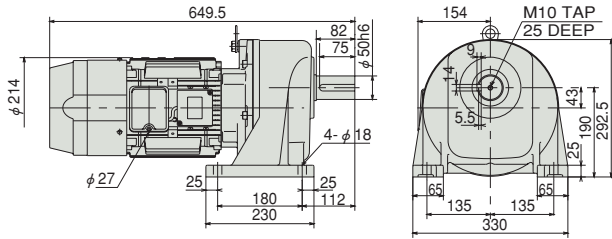

Note) For 400 V, the DC module is incorporated in the terminal box.

B-65 3.7kW GMTA370-50F5~30B

Reduction ratio : 5, 10, 15, 20, 25, 30	Approx. weight : 82.0kg
Reference page : Specification Chart→P27	

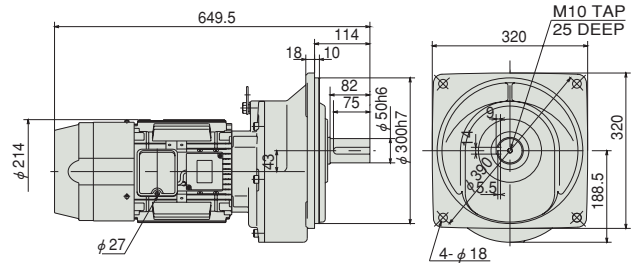

Note) For 400 V, the DC module is incorporated in the terminal box.

B-64 3.7kW GMTA370-50L40~50B

Reduction ratio : 40, 50	Approx. weight : 84.0kg
Reference page : Specification Chart→P27	

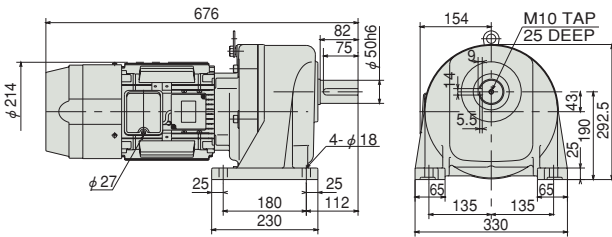

Note) For 400 V, the DC module is incorporated in the terminal box.

B-66 3.7kW GMTA370-50F40~50B

Reduction ratio : 40, 50	Approx. weight : 86.0kg
Reference page : Specification Chart→P27	

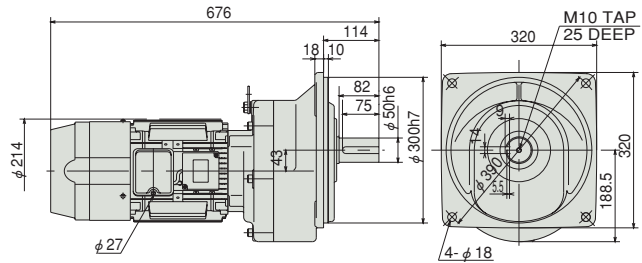

Note) For 400 V, the DC module is incorporated in the terminal box.

Three-phase 5.5 kW · L : Foot mount type / F : Flange mount brake type

GEAR MOTOR TA Series

B-67 5.5kW GMTA550-50L5~30B

Reduction ratio : 5, 10, 15, 20, 25, 30	Approx. weight : 104.0kg
Reference page : Specification Chart→P27	

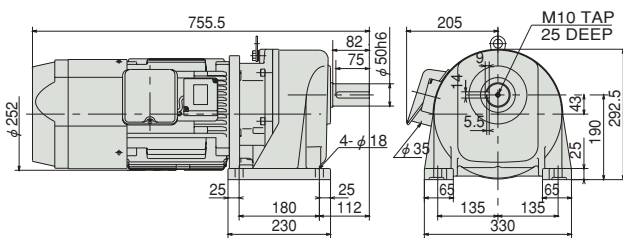

We can make it to order with short lead times.

B-68 5.5kW GMTA550-50F5~30B

Reduction ratio : 5, 10, 15, 20, 25, 30	Approx. weight : 107.0kg
Reference page : Specification Chart→P27	

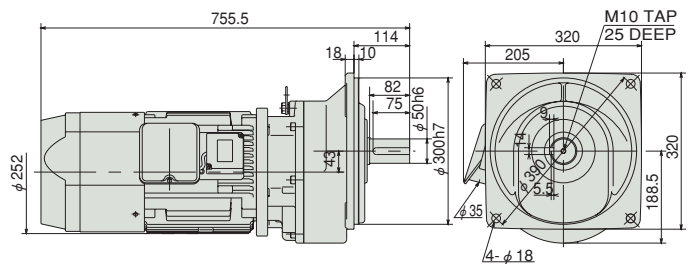

We can make it to order with short lead times.

Brake-Type Gear Motor TA Series Outline Dimensions

Single-phase 100 W · L : Foot mount brake type

GEAR MOTOR TA Series

B-69 100W GMTA100-18L5B

Reduction ratio : 5 Approx. weight : 8.6kg
Reference page : Specification Chart→P25

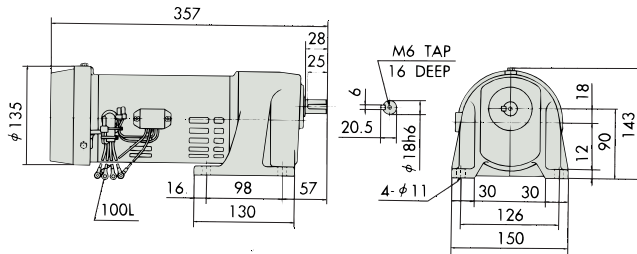

B-72 100W GMTA100-28L300~450B

Reduction ratio : 300, 360, 450 Approx. weight : 12.5kg
Reference page : Specification Chart→P25

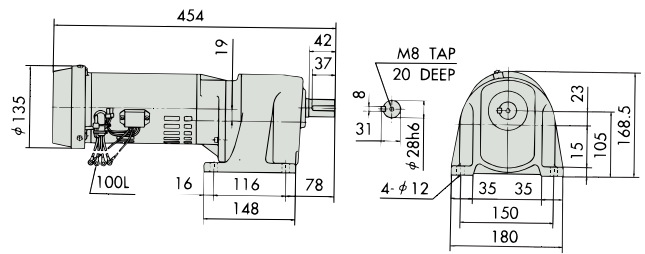

B-70 100W GMTA100-18L10~50B

Reduction ratio : 10, 15, 20, 25, 30, 40, 50 Approx. weight : 7.4kg
Reference page : Specification Chart→P25

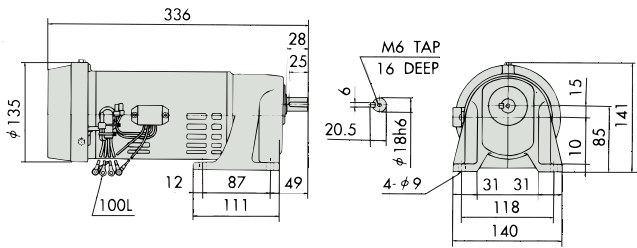

B-73 100W GMTA100-38L600~1200B

Reduction ratio : 600, 720, 1000, 1200 Approx. weight : 16.0kg
Reference page : Specification Chart→P25

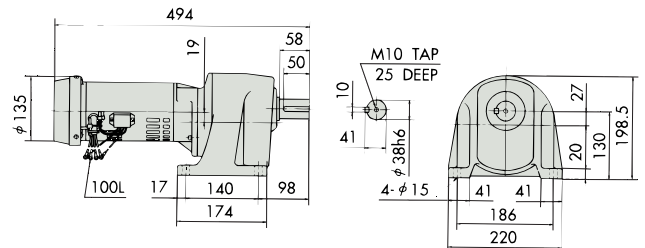

B-71 100W GMTA100-24L60~200B

Reduction ratio : 60, 75, 100, 120, 165, 200 Approx. weight : 8.8kg
Reference page : Specification Chart→P25

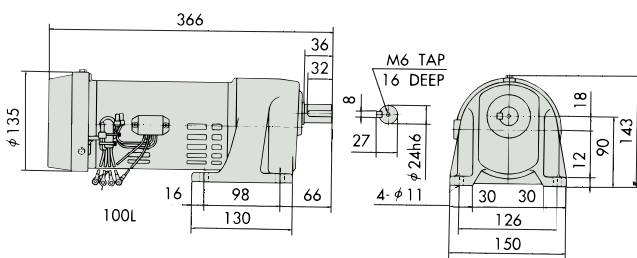

Outline Dimensions

L

B-69
B-70
B-71
B-72
B-73

100

Brake-Type Gear Motor TA Series Outline Dimensions

Single-phase 100 W · U : Face mount brake type

GEAR MOTOR TA Series

B-74 100W GMTA100-18U5B

Reduction ratio : 5 Approx. weight : 8.6kg
 Reference page : Specification Chart→P25 Options→P57

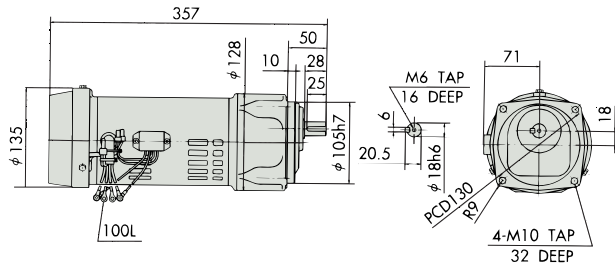

B-77 100W GMTA100-28U300~450B

Reduction ratio : 300, 360, 450 Approx. weight : 12.0kg
 Reference page : Specification Chart→P25 Options→P57

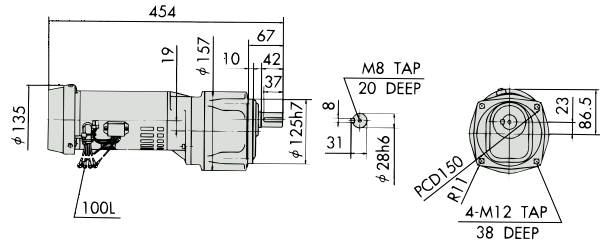

B-75 100W GMTA100-18U10~50B

Reduction ratio : 10, 15, 20, 25, 30, 40, 50 Approx. weight : 7.2kg
 Reference page : Specification Chart→P25 Options→P57

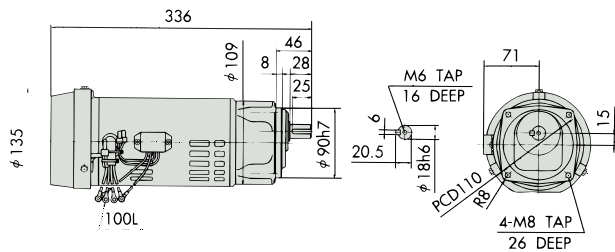

B-78 100W GMTA100-38U600~1200B

Reduction ratio : 600, 720, 1000, 1200 Approx. weight : 22.0kg
 Reference page : Specification Chart→P25 Options→P58

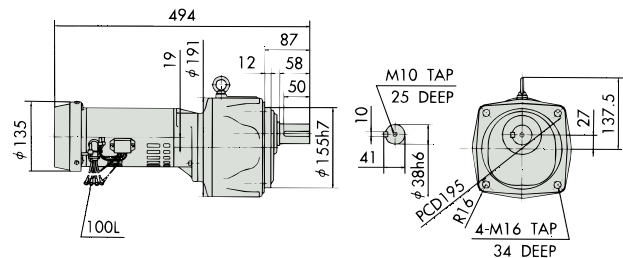

B-76 100W GMTA100-24U60~200B

Reduction ratio : 60, 75, 100, 120, 165, 200 Approx. weight : 8.6kg
 Reference page : Specification Chart→P25 Options→P57

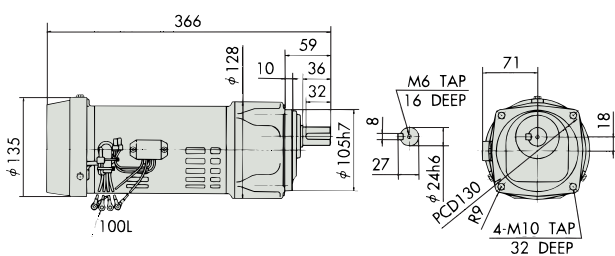

Outline Dimensions

U
 B-74
 B-75
 B-76
 B-77
 B-78

100

Brake-Type Gear Motor TA Series Outline Dimensions

Single-phase 200 W · L : Foot mount brake type

GEAR MOTOR TA Series

B-79 200W GMTA200-18L5B

Reduction ratio : 5 Approx. weight : 10.5kg
Reference page : Specification Chart→P25

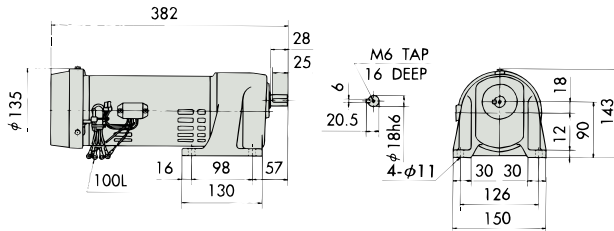

B-82 200W GMTA200-28L100~200B

Reduction ratio : 100, 120, 165, 200 Approx. weight : 13.0kg
Reference page : Specification Chart→P25

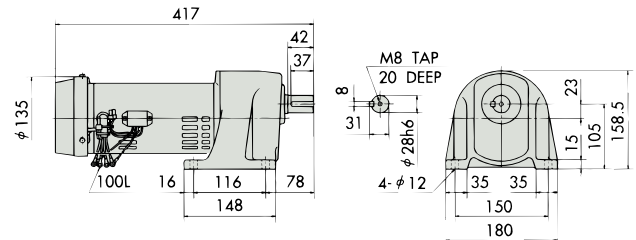

B-80 200W GMTA200-18L10~25B

Reduction ratio : 10, 15, 20, 25 Approx. weight : 9.2kg
Reference page : Specification Chart→P25

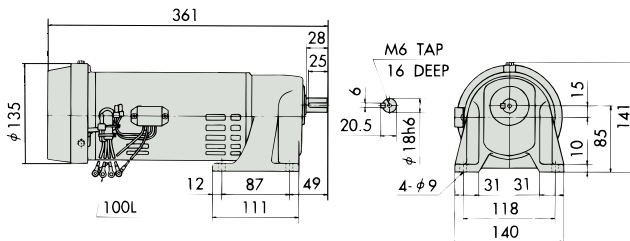

B-83 200W GMTA200-38L300~450B

Reduction ratio : 300, 360, 450 Approx. weight : 19.0kg
Reference page : Specification Chart→P25

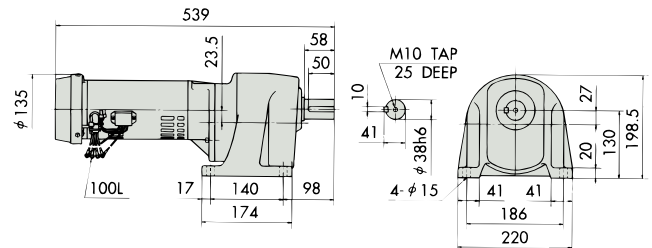

B-81 200W GMTA200-24L30~75B

Reduction ratio : 30, 40, 50, 60, 75 Approx. weight : 10.5kg
Reference page : Specification Chart→P25

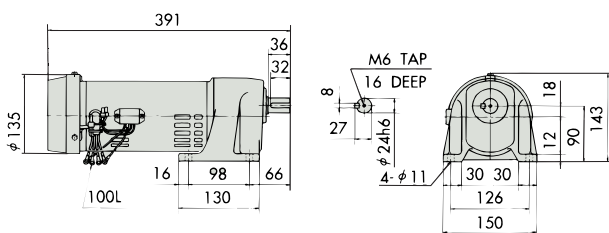

B-84 200W GMTA200-42L600~1200B

Reduction ratio : 600, 720, 1000, 1200 Approx. weight : 40.8kg
Reference page : Specification Chart→P25

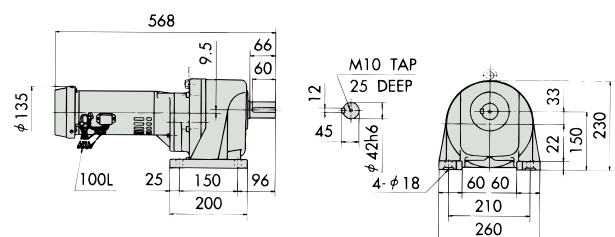

Outline Dimensions

L
B-79
B-80
B-81
B-82
B-83
B-84

200

Brake-Type Gear Motor TA Series Outline Dimensions

Single-phase 200 W · U : Face mount type / F : Flange mount brake type

GEAR MOTOR TA Series

B-85 200W GMTA200-18U5B

Reduction ratio : 5	Approx. weight : 10.5kg
Reference page : Specification Chart→P25 Options→P57	

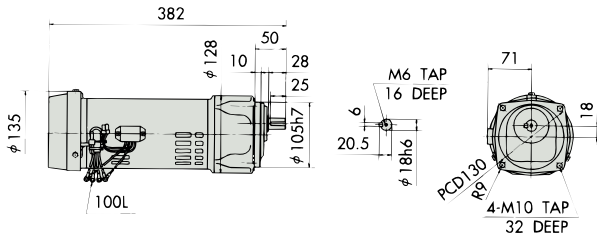

B-88 200W GMTA200-28U100~200B

Reduction ratio : 100, 120, 165, 200	Approx. weight : 13.0kg
Reference page : Specification Chart→P25 Options→P57	

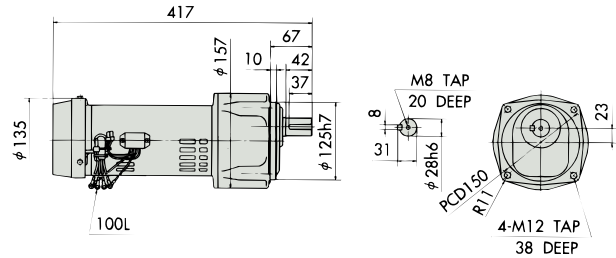

B-86 200W GMTA200-18U10~25B

Reduction ratio : 10, 15, 20, 25	Approx. weight : 9.0kg
Reference page : Specification Chart→P25 Options→P57	

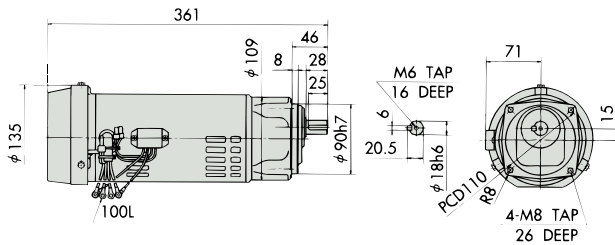

B-89 200W GMTA200-38U300~450B

Reduction ratio : 300, 360, 450	Approx. weight : 24.5kg
Reference page : Specification Chart→P25 Options→P57	

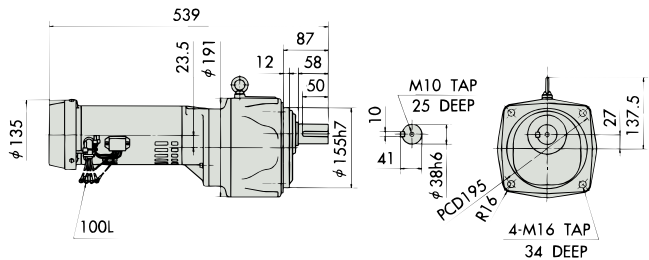

B-87 200W GMTA200-24U30~75B

Reduction ratio : 30, 40, 50, 60, 75	Approx. weight : 10.5kg
Reference page : Specification Chart→P25 Options→P57	

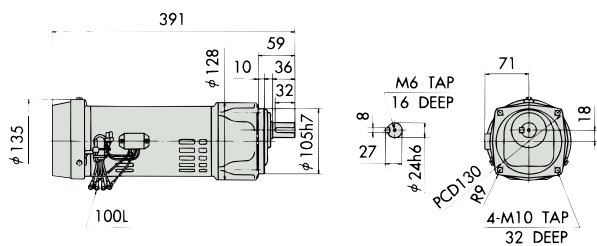

B-90 200W GMTA200-42F600~1200B

Reduction ratio : 600, 720, 1000, 1200	Approx. weight : 41.8kg
Reference page : Specification Chart→P25	

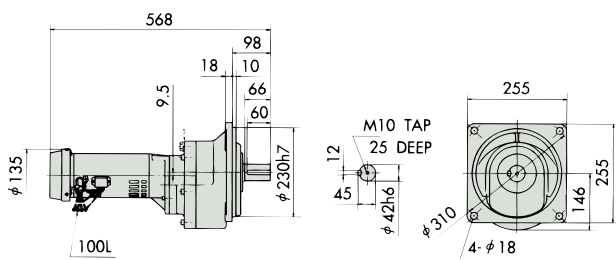

Outline Dimensions

U.F

B-85
B-86
B-87
B-88
B-89
B-90

200